

## IGV-B4820



The **IGV-B4820** is an advanced high-speed progressive scan, fully programmable CCD camera designed for imaging applications that require high frame rates, high quality images, and powerful features and flexibility. The camera has a small size, light weight, and is built around Kodak's KAI-16000 Interline transfer CCD image sensor with a 43.3 mm image diagonal. IGV-B4820 is available with Ethernet output (GigEVision compliant).

The B4820 provides an image resolution of 4904 x 3280 and delivers up to 4.2 frames per second at full resolution. The camera image processing engine is based on a high-speed, high-density FPGA, featuring programmable resolution, speed, 8 independent AOIs, binning, triggering, exposure control, line and frame time, I/O mapping, external/internal sync, AGC, AEC, Auto Iris, transfer function correction, user LUT, Defective and Hot Pixel Correction (DPC, HPC), and Flat Field Correction (FFC). MTBF of 660,00 hrs. @ 40°C.

### Features

- 4904/4872 x 3280/3248
- Mono and color - 8/10/12/14-bit data
- Normal and over-clock operation (3.2/4.2 fps)
- Ethernet output, GigEVision and Gen<I>Cam support
- Two dimensional Flat Field Correction
- RS232 serial communication
- Analog and digital gain and offset control
- 1x, 2x, 3x, 4x, 8x horizontal and vertical binning
- Eight (8) independent horizontal and vertical AOIs
- Programmable horizontal and vertical resolution
- Programmable line time, frame time and speed
- Programmable external trigger:
  - 3 triggering sources
  - 5 triggering modes
- Automatic gain, exposure and iris control

- Internal/External exposure control
- Internal/External H and V sync input/output
- Left/right digital bit shift
- Test image with image superimposition
- Built in pulse generator
- Programmable I/O mapping
  - 4 programmable inputs
  - 3 programmable outputs
- Dynamic transfer function correction
- Dynamic black level correction
- Defective and hot pixel correction
- Temperature monitor
- Field upgradeable firmware, LUT, DPC, HPC, FCC

### Applications

- Industrial
- Medical
- Microscopy
- Military
- Scientific
- Surveillance

# Specifications for Bobcat IGV-B4820

Maximum Resolution	4904 x 3280
Sensor Type	43.3 mm diagonal CCD KAI-16000
Pixel Size	7.40 $\mu$ m
Frame Rate	3.2/4.2 fps (normal/overclock)
Max Frame Rate	18 fps
Minimum S/N ratio	60 db
Video Output	RJ45 CAT 5e, CAT6
Output Format	mono 8/10/12/16, mono 10/12 packed, bayer 8/10/12
Binning H & V	x1, x2, x3, x4, x8
Area of Interest	8 independent AOIs, 2 x 2 to 4904 x 3280
Shutter Speed	1/67000 to 1/1.5 sec
Long Integration	Up to 16 sec
Gamma Correction	G=1.0, G= 0.45, user upgradable LUT
Video Gain	36 dB range, 1024 steps, 0.0351 dB per step
Exposure and AGC	Manual, Auto, Programmable
Iris Control	Auto, Programmable
Hardware Trigger	LVTTL or TTL via IN1/IN2, optically isolated, level, edge, pulse-width, programmable
Software Trigger	Software, internal, level, edge, pulse-width, programmable
Trigger Modes	Programmable, standard, double exposure, fast, frame accumulation, asynchronous
Strobe Output	Programmable position and duration
Image Overlay	Yes, Programmable
RS232 Interface	Yes
Data Corrections	DPC, HPC, LUT, FCC
Min. Illumination	1 Lux, F/1.4
Power Input Range	12 VDC, (10 V – 15 V)
Power Consumption	5.8 W
Size (W x H x L), Weight	60 x 60 x 60mm, 375g
Lens Mount	F mount
Vibration, Shock	10G (20 - 200)Hz XYZ, 70G
Environmental	Operation (-30° to 60°) C, storage (-40° to 70°) C
Humidity	10% to 90% non-condensing
MTBF	MTBF of 660,00 hrs. @ 40°C

## Power and I/O Interface

Connector: Hirose HR 10A-10R-12PB(71)

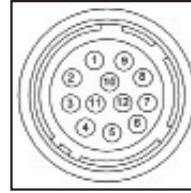

<b>1</b>	12V DC Return	<b>7</b>	OUT1 Signal
<b>2</b>	+12V DC	<b>8</b>	IN1 Signal
<b>3</b>	IRIS VCC	<b>9</b>	IN2 Signal
<b>4</b>	IRIS Video	<b>10</b>	IN1/2 Return
<b>5</b>	IRIS Return	<b>11</b>	Spare
<b>6</b>	OUT1/2 Return	<b>12</b>	OUT2 Signal

## Power Requirements

12V DC, (10V min, 15V max)  
450 mA steady, 1.5 A inrush  
5.4 W

## Accessories

PS12V04: Power Supply (sold separately)  
PS12V05 Power Supply with Auto Iris (sold separately)

## Ordering Information

Order: **IGV-B4820M-KFO**

### Camera Family

**B**-Bobcat Family

### Sensor Type

**M**-Monochrome

**C**-Color

### Lens Mount

**F**-“F” Mount (default)

### CCD

**K**-Kodak

## Spectral Response

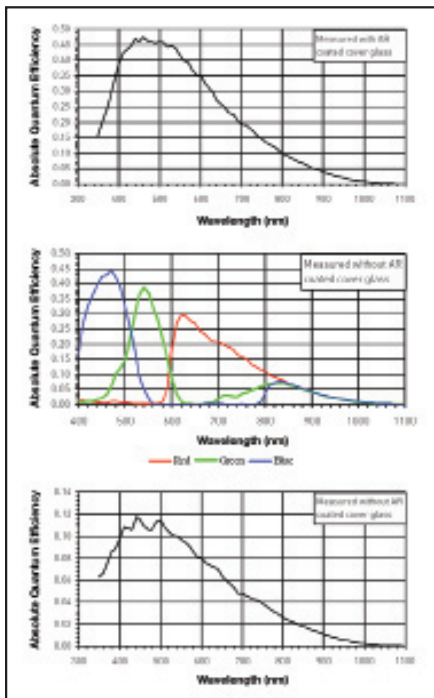

## Software/Drivers/Interface

**GigE Protocol:** 10/100/1000 Mb/s, 802.3, Ethernet v2.0, IPv4, IGMPv.2, UPD and ICMP

**Drivers for:** Windows 2000/XP/XP-64/ Vista32/Vista64/Win 7-32/Win 7-64/SuSE 10/ RedHat 5/ and others

**Software:** GigE Vision Player

**SDK:** C++GigE Vision Software Developers Kit

**Support for:** Labview, ImagePro, Halcon, MIL, eVision, CommonVision, StreamPix, CoreView, Streams5, Absoft Active GigE, and others

**Multicast capable**

## Mechanical Dimensions

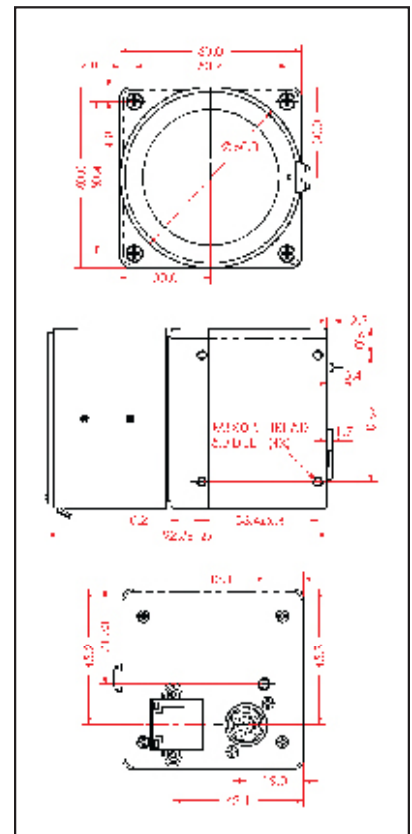

Copyright © 2009, Imperx, Inc. Product information subject to change without notice. Rev. 2.0, 06/2011

## Distribution in the UK



**Lambda Photometrics Ltd**, Lambda House, Batford Mill, Harpenden, Hertfordshire AL5 5BZ

**E:** info@lambdaphoto.co.uk **W:** www.lambdaphoto.co.uk **T:** +44 (0)1582 764334 **F:** +44 (0)1582 712084

The leading supplier of scientific and industrial lasers, optical systems and associated accessories, fibre optic components and instrumentation, and machine vision products.