



FLUOROPTIC® THERMOMETER

m3300 Biomedical Lab Kit

Flexible Fiber Optic Thermometer for Medical MRI and RF Research

Industry Standard for Fiber Optic Thermometry

Luxtron's m3300 Biomedical Lab Kit is a rugged fiber optic thermometer designed for demanding medical applications. Ideally suited for laboratory, research, and academic settings requiring precise and repeatable temperature measurements, this kit is based on Luxtron's patented Fluoroptic® technology. The EMI immunity and inherent stability of this technology eliminates the problems encountered when using conventional thermocouple or thermistor sensors in RF, microwave, and MR environments.

Easy to Use

The m3300 Biomedical Lab Kit includes an instrument encased in an all steel enclosure, protecting it in the harsh EMI environments. The system is FDA 510(k) classified and is easily integrated into any PC-based data acquisition system. Connection to a PC serial port serves as the communication interface to change settings and log data using standard software. Luxtron also offers an optional TrueTemp graphing and data analysis software for PCs. This m3300 kit includes a 0-10V analog output, medical grade power supply, RS-232 cable, users manual and convenient carrying case.

100% Non-metallic Probes

The biomedical probe for use with the m3300 are entirely non-metallic in construction, minimally invasive, and suitable for direct insertion into patient tissue. The probes are protected in a Tefzel® jacket and are only 0.5mm in diameter. The chemically inert Fluoroptic® probes are safe in almost any environment and can be sterilized.



Benefits

- *MR Compatible and FDA 510(k) Classified*
- *Probes Immune to EMI, RF, MR and Microwave Interference.*
- *Precise Measurements from Very Small Sensor*
- *Rapid Response Time of 0.25 Seconds*
- *Minimally Invasive Probes*

Applications

- *Core Temperature Monitoring during MRI Scans*
- *Tissue Temperature Monitoring during RF or Microwave Treatments*
- *Heat Generation Monitoring of Implanted Devices during MRI Scans*
- *Temperature Monitoring of Animal Testing Campaigns*
 - *Various Probes for Surface and Immersion Monitoring*

FLUOROPTIC® THERMOMETER

m3300 Biomedical Lab Kit

Flexible Fiber Optic Thermometer for Medical MRI and RF Research

Specifications

Channels	4
Measurement Range	0 to 120°C
Electrical Interference	Immune to MR, EMI, RF, and microwave
Accuracy (Calibrated)	±0.2°C within 20° C of Calibration Point
Repeatability (Precision)	±0.5°C RMS @ 8 Samples per Measurement
Output Resolution	0.01°C
Measurement Rate	1 to 4Hz per Channel, Configurable
Output Format	Selectable °C, °F and °K
Self Diagnostic	Self Diagnosis and Probe Errors Available on RS-232
Input Power	85-264 VAC (Universal medical-grade power supply included)
Serial Output	RS-232C
Analog Output	0 -10V DC
Dimensions	108mm H x 144mm W x 50mm D
Storage Temperature	-30 to +75°C
Operating Environment	0°C to 40°C, 80% RH (Max) Non-condensing

Kit Includes

- 4-Channel Instrument
- Universal Medical Grade Power Supply (Input 85-264 VAC, 49-63 Hz)
- Cable for RS-232 Serial Communication
- User's Guide and Convenient Carrying Case

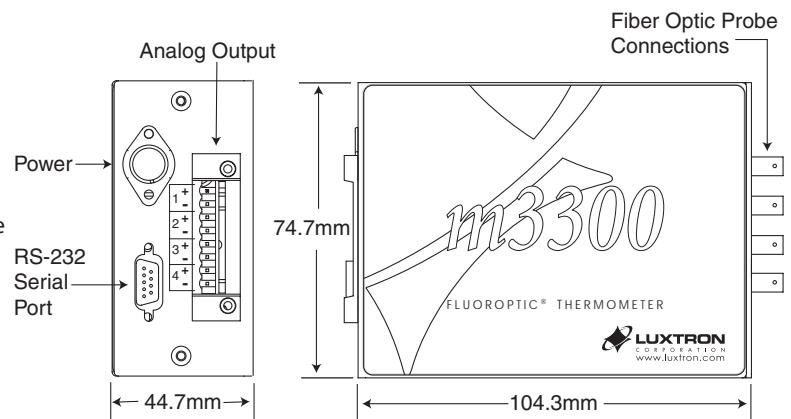

Standard Probe and Extension

STB Probe

Temperature Range	0 to 120°C
Length	1 meter
Response Time	0.25 seconds in stirred liquid
Fiber Type	200µm hard clad silica fiber with Tefzel® jacket
Color	Black
Connector Type	RPC-1 molded plastic

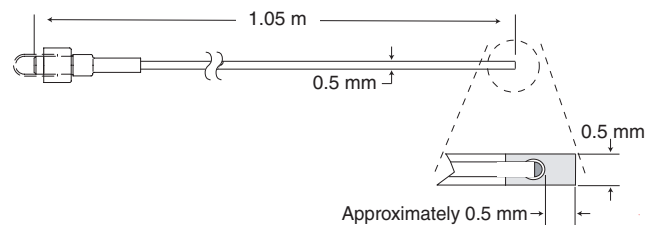

FOC-ST Extension (one extension required per probe)

Lengths	2, 5, and 10 meter
Fiber Type	400µm silica fiber protected with Kevlar® and PVC
Color	Black
Connector Types	RPC-1 molded plastic to ST

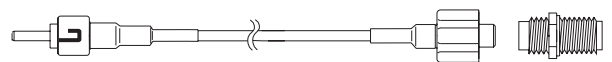

Your local Luxtron representative is:

Specifications subject to change without notice. Luxtron and Fluoroptic are registered trademarks and TrueTemp is a trademark of Luxtron Corporation. ©2005 Luxtron Corporation. All rights reserved.



LUXTRON®
Direct, Dynamic, Real Time
 3033 Scott Blvd., Santa Clara, CA 95054-3316
 408.727.1600 tel 408.727.1677 fax
 www.luxtron.com