

Small Instrumentation Modules

SIM960 — 100 kHz analog PID controller

- **Analog signal path / digital control**
- **100 kHz bandwidth**
- **Low-noise front end**
- **P, I, D and Offset settable to 0.5 %**
- **Anti-windup (fast saturation recovery)**
- **Bumpless transfer, manual to PID**
- **Analog setpoint with smooth ramping**
- **Smooth upper/lower limit clamping**



SIM960 Analog PID Controller

The SIM960 Analog PID Controller is a unique instrument intended for the most demanding control applications. It combines analog signal handling with digital control, giving you the best of both worlds. High bandwidth (100 kHz) control loops may be implemented without discrete time or quantization artifacts.

The low-noise front end brings better performance to noise sensitive applications including laser power and wavelength stabilization, cryogenics, scanning probe microscopy, and others. User-settable gain of up to 1000 \times means greater flexibility, reducing the need for input preamplification. The unit can be used together with the SIM921 AC Resistance Bridge, providing a flexible and cost-effective temperature control solution.

An internal ramp generator can control voltage slew rate between predefined start and stop setpoints. The output is clamped within upper and lower user limits to guard against

system overload. The conditional integration electronics provide anti-windup on the integrating capacitors, leading to faster recovery from saturation conditions.

Front-panel control enables easy modification of system parameters and convenient monitoring of input and output signals. Power and serial communication are via a 15-pin D-sub connector which mates with the SIM900 mainframe. All instrument parameters can be set and queried via the serial interface.

The amplified error signal ($P \times \epsilon$) and the output may be monitored with an LED bar display or via the millivolt resolution numeric display. The Setpoint and Measure input signals can also be monitored on the numeric display.

Control type	Analog, PID + Offset
Proportional gain	10^{-2} to 10^3
Integral gain	10^{-1} s^{-1} to 10^5 s^{-1} (effective time constant 10^{-5} s to 10 s)
Derivative gain	10^{-7} s to 1 s
Offset	$\pm 10 \text{ V}$, 1 mV resolution
Bandwidth	100 kHz
Propagation delay	$1 \mu\text{s}$ (typ.)
Noise (typ.)	$8 \text{ nV}/\sqrt{\text{Hz}}$ above 10 Hz (ref. to input)
Parameter control	Digital
Parameter accuracy	1%
Stability	$200 \text{ ppm}/^\circ\text{C}$
Setpoint	
External	Front BNC input
Internal	$\pm 10 \text{ V}$ range with 1 mV resolution
Setpoint noise	$20 \text{ nV}/\sqrt{\text{Hz}}$ above 100 Hz
Ramp	Internal setpoint linear ramping from 10^{-3} to 10^4 V/s
Amplifier output	$\pm 10 \text{ V}$ with adj. upper/lower limits
Display resolution	4 digits
Units	s^{-1} , s , V , V/s
Operating temperature	0°C to 40°C , non-condensing
Interface	Serial via SIM interface
Connectors	BNC (3 front, 2 rear) DB15 (male) SIM Interface
Power	$\pm 15 \text{ V}$ (150 mA), $+5 \text{ V}$ (80 mA)
Dimensions	$3.0" \times 3.6" \times 7.0"$ (WHD)
Weight	2.1 lbs.
Warranty	One year parts and labor on defects in materials and workmanship



SIM960 rear panel

Ordering Information

SIM960 Analog PID controller

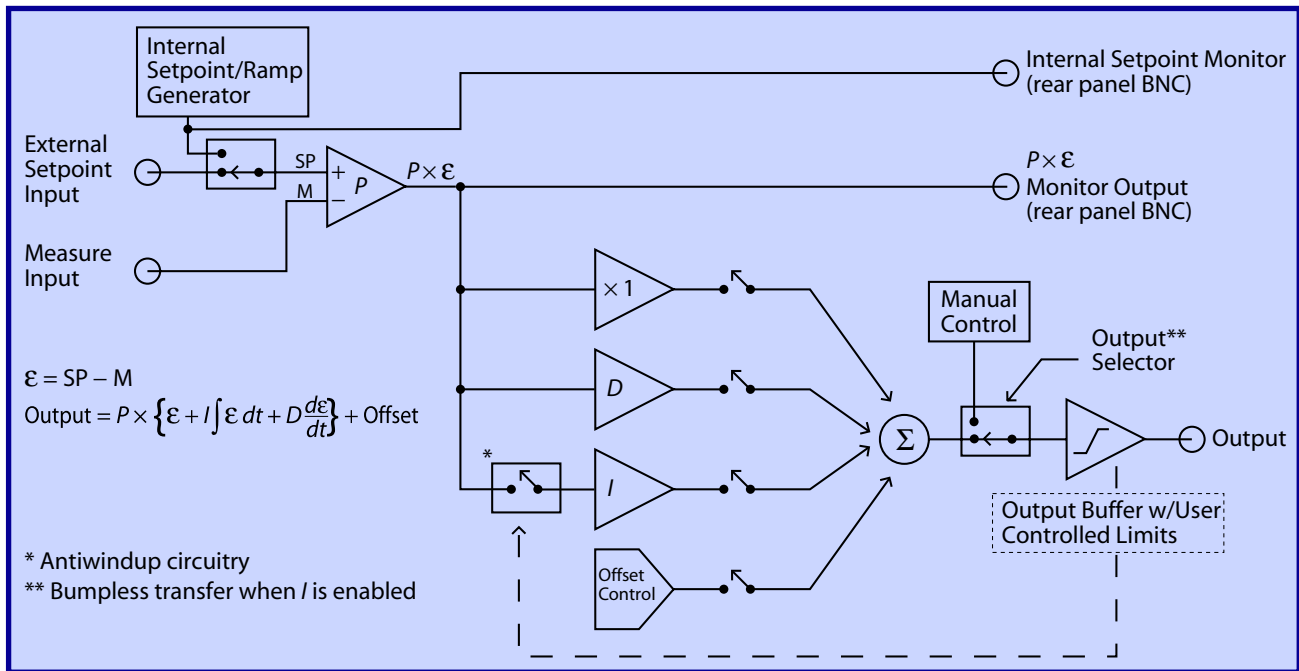

SIM960 block diagram