

# Ultra Specifications:

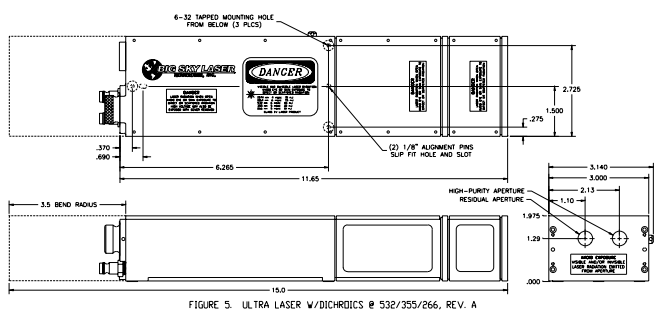
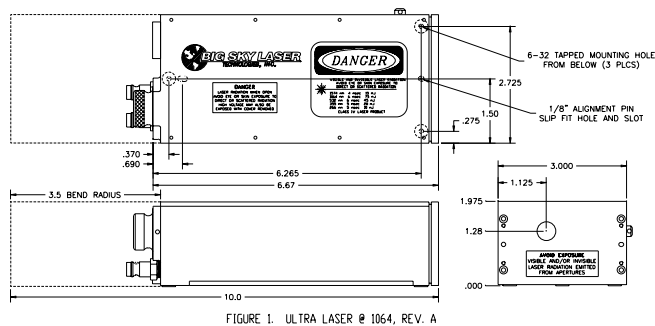
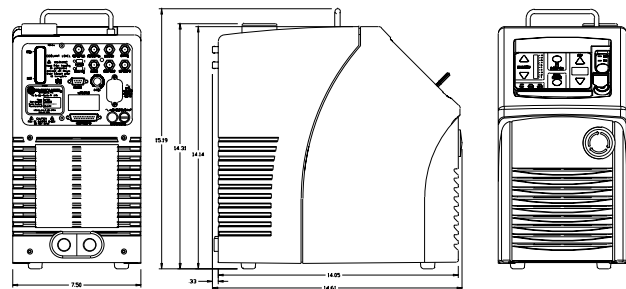

Ultrastable : transverse multimode resonator with high energy stability.  
GRM : graded reflectivity mirror for transverse monomode configuration.

	Wavelength	Brilliant Ultra Resonator GRM	Ultrastable
Pulse Repetition Frequency (Hz)		20	20
Output Energy (mJ)	1064 nm	50	50
	532 nm	30	30
	355 nm	6	
	266 nm		4
	1574 nm		8
Pulse-to-Pulse Energy Stability (%)	1064 nm	4	2
	532 nm	5	2.5
	355 nm	6	
	266 nm		3
	1574 nm		5
Power drift (%) over 8 hour period - ambient temp. $\pm 5^{\circ}\text{C}$	1064 nm	10	10
	532 nm	10	10
	355 nm	10	
	266 nm		10
	1574 nm		10
Pulse Width - FWHM (ns)	1064 nm	<8	<8
	532 nm	<7	<7
	355 nm	<6	
	266 nm		<6
	1574 nm		<8
Linewidth (cm <sup>-1</sup> )	1064 nm	1	1
	532 nm	2	2
	355 nm	3	3
	266 nm		$\pm 2$
	1574 nm		$\pm 2$
Jitter (ns)	1064 nm	$\pm 2$	$\pm 2$
	532 nm	$\pm 2$	$\pm 2$
	355 nm	$\pm 2$	
	266 nm		$\pm 2$
	1574 nm		$\pm 2$
Pointing stability ( $\mu\text{rad}$ )	1064 nm	<100	<50
	532 nm	<100	<50
	355 nm	<1	<8
	266 nm		<7
	1574 nm		<12
Divergence @ 86.5% of energy (mrad)	1064 nm	<1.5	<8
	532 nm	<1	<8
	355 nm	<1	
	266 nm		<7
	1574 nm		<12
Rod diameter (mm)		<3	<3
Spatial profile in Far Field (fit to gaussian)	1064 nm	>0.90	
	532 nm	>0.90	
	355 nm	>0.90	
Spatial profile in Near Field	1064 nm		Top Hat
	532 nm		Top Hat

### Specifications that apply to both GRM and Ultrastable models

Maximum Altitude	3 000m / 10 000 ft
Flashlamp Lifetime	>20 Million Shots
Operating Temperature	10-40°C
Storage Temperature	5-50°C
Main Line	110 / 240 V - 50 / 60 Hz

VISIBLE AND INVISIBLE LASER RADIATION  
AVOID EYE OR SKIN TO DIRECT  
OR SCATTERED RADIATION.

CLASS 4 LASER RADIATION PRODUCT	
Max Average Power	: 1 W
Max Energy/pulse	: 50 mJ
Pulse duration	: <10ns
Emitted Wavelength	: 266/1064nm



# Ultra

Brilliant Ultra : compact and rugged Q-Switched Nd:YAG oscillator. Ultrastable or GRM resonator.

Rod diameter : 3mm - 1 flashlamp - air/water exchanger

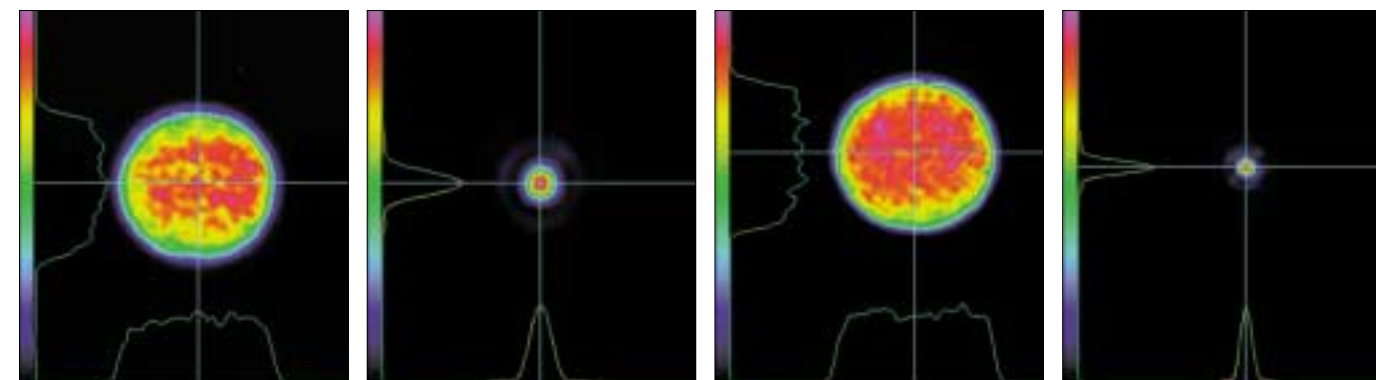

Beam profile in near field @ 1064nm, 20Hz, Ultrastable

Beam profile in far field @ 1064nm, 20Hz, GRM

Beam profile in near field @ 532nm, 20Hz, Ultrastable

Beam profile in far field @ 532nm, 20Hz, GRM

### Weight & dimensions

Optical laser head :	1 kg (2 lb)
(H x L x W)	51 x 203 x 76mm (2 x 8 x 3 inch)

Power supply and cooling unit :	15 kg (30 lb)
(H x L x W)	360 x 370 x 190mm (14.3 x 14.6 x 7.5 inch)
Cable length 1.8 m (6 ft)	

Harmonic generator with dichroics :	0.25 kg (1/2 lb)
(H x L x W)	51 x 137 x 76mm (2 x 5.4 x 3 inch)



The Ultra's operator interface panel includes easy-to-read LED displays with simple, push button adjustments. All controls are also available via standard RS232 interface.





**T**he new Brilliant Ultra is designed by Big Sky Laser Technologies, the Quantel's US subsidiary, for those users looking for compact, rugged performance in a versatile, affordable package. More and more users are taking their laser systems out of the lab and into harsh, uncontrolled environments. They expect high performance, rugged reliability and ease of operation even in these demanding conditions. The Brilliant Ultra meets these needs.

## Compact...

With lasers being taken to "real-world" applications, today's user is looking for small size.

- **Folded Configuration.** The Ultra uses Big Sky Laser's unique Compact Folded Resonator (CFR) design to significantly decrease its footprint.
- **Laser Head Size.** Ultra's small size makes it a natural for microscope mounting or for integration into your instrument.
- **Electronics Cooling System.** The compact, rugged design does not end with the laser head alone. Ultra's versatile power supply gives you more working space while the standard RS232 interface allows for remote placement and control.



## Rugged...

Rugged reliability and versatility are key factors for lasers used in demanding, uncontrolled, non-laboratory environments.

- **Shock and Vibration.** Subjecting a laboratory laser to "field and/or industrial conditions" is a risky proposition at best. Ultra incorporates proven rugged design features of Big Sky Laser's CFR lasers. Stiff I-beam optical bed construction, hard-mounted, non-adjustable mirrors and lock-down, rotating optical alignment wedges provide unparalleled ruggedness
- **Environmentally Sealed Head.** Dirt, condensation, dust and so forth can spell disaster for Q-switched lasers. The Brilliant Ultra O-ring sealed optical head translates to reliable performance in harsh industrial and field conditions.
- **Wide Temperature Operating Range.** The same design features that enhance the ruggedness of the laser, also allow it to operate over a wider temperature range. Because you can't always control the environment to within a few degrees, you need a laser designed to handle such conditions.

## Turn-key...

Many users today are not laser technicians. They view the laser as simply a "plug-and-run" type of tool that operates when needed. Quantel and Big Sky Laser designed the Brilliant Ultra to be extremely user-friendly, easy to operate and easy to maintain.

- **Flexible, User-Friendly Operation.** The Brilliant Ultra is a



The ULTRA's flashlamp replacement is the easiest in the industry. The process is comparable to changing a fuse.



turn-key laser system. Push button controls on the front panel are easy to read and adjust. Simply select the desired repetition rate and energy level, then GO ! External computer control is available through the standard RS232 port.

- **Few Adjustments.** The Brilliant Ultra was designed so the user never has to align the resonator. Quantel believes that frequent "peaking and tweaking" or re-optimization of the laser is an unnecessary nuisance that takes time away from the primary job.
- **Quick Lamp Change.** Although lamp changes will be infrequent with the ULTRA's estimated 30 million shot lamp life, this maintenance action has been greatly simplified. Lamps are nearly as easy to change as a fuse. This feature has proven important to OEM users.
- **OEM Compatible.** The Brilliant Ultra is specifically designed for applications where a low energy, compact laser is well suited to do the job. Quantel's emphasis on OEM hardware means we're ready to discuss a custom Brilliant Ultra for your application.



Easy access to synchronization I/O, RS232 interface, shots counter, water level...

If you've been searching for a high performance, compact, rugged Nd :YAG laser source, call Quantel or its nearest representative to discuss the Brilliant Ultra and your application.

