



FLUOROPTIC® THERMOMETER

FOT Lab Kit

Flexible Fiber Optic Thermometer for R&D Environments

Field Proven Fiber Optic Sensors

The FOT Lab Kit is a 4-channel fiber optic thermometry system that allows users to measure temperature where conventional sensors fail. Luxtron's patented technology, known as Fluoroptic® Thermometry (FOT), offers probes that are totally immune to electromagnetic interference (EMI) and entirely non-metallic in construction. These qualities make FOT instruments perfectly suited for measuring temperature in harsh environments often encountered during research, such as high voltages and strong radio frequencies (RF).

Flexible, Easy to Use

The FOT Lab Kit includes a Fluoroptic® thermometer shielded in a metal enclosure, universal power supply, RS-232 cable, users manual and compact carrying case.

Data is logged with any terminal program (such as Microsoft Windows® Hyperterminal) or with Luxtron's optional TrueTemp graphing and data capture PC software. The FOT Lab Kit interfaces with data acquisition devices through the analog output (0-10VDC or 4-20mA) or the RS-232 port.

Compatible with Every Application

A wide variety of probe configurations (immersion, surface, remote and extensions) are available for specific measurement applications. Available probes are shown in the Luxtron FOT Probe and Extension data sheet. These unique Fluoroptic® probes are non-metallic, electrically non-conductive and immune to electromagnetic interference and voltages that adversely affect thermocouples, thermistors and RTDs.



Benefits

- *Probes immune to EMI, RF, MRI and Microwave Interference*
- *Customer Chosen Calibration Point*
- *Flexible Programming Parameters for R&D*
 - *Measurement Rate*
 - *Samples per Measurement*
 - *Output Format*
- *Set It and Forget It ... Stable and Inert Sensor*

Applications

- *Heat Induction Testing of Implantable Devices in MRI Fields*
- *Temperature Monitoring/Control of Dielectric (RF and microwave) Heating Processes*
- *Temperature Control Experimentation of Semiconductor RF Process Chambers*
- *Heat Generation Monitoring of Live Integrated Circuits*

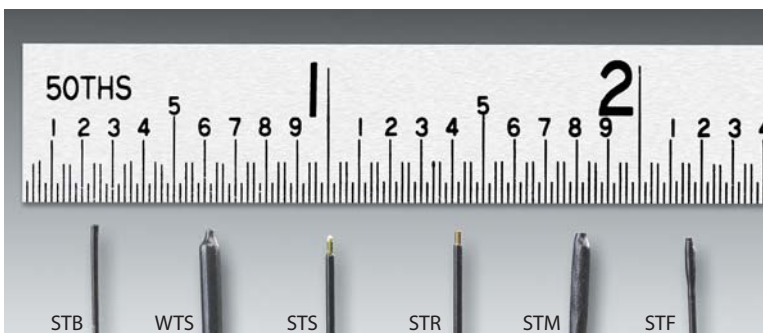

FLUOROPTIC® THERMOMETER

FOT Lab Kit

Flexible Fiber Optic Thermometer for R&D Environments

Specifications

Channels	4
Measurement Range	-100 to 330°C
Electrical Interference	Probe Immune to EMI, RF, Magnetic and Microwave
Accuracy (Calibrated)	±0.5°C within 50°C of Calibration Point
Repeatability (Precision)	0.5°C RMS @ 8 Samples per Measurement
Output Resolution	0.01°C
Measurement Rate	1 to 4 Hz per Channel, Configurable
Output Format	Selectable °C, °F and °K
Self Diagnostic	Self Diagnosis and Probe Errors Available on RS-232
Input power	100-240VAC Universal Power Supply Included
Serial Output	RS-232C
Analog Output	0-10V or 4-20mA
Dimensions	74.7mm H x 44.7mm W x 104.3mm D
Storage Temperature	-30 to +75°C
Operating Environment	10°C to 50°C, 80% RH (Max) Non-condensing

Compatible Probes*

Type	Temperature Range	Application
STF	0 to 295°C	General Immersion
STM	-25 to 250°C	General Immersion
STR	-25 to 330°C	Remote Sensing
STS	-25 to 200°C	Surface Contact
STB	0 to 120°C	Medical
WTS	-30 to 200°C	Electric Power

* For more information and probe specifications see Probes and Accessories data sheet.

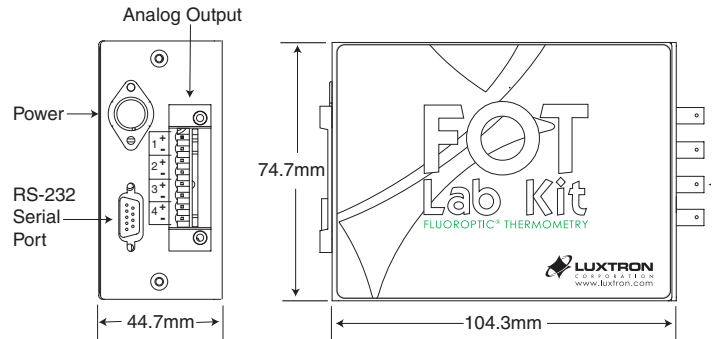

Kit Includes

- 4-Channel Instrument
- Universal Power Supply (100-240VAC)
- Cable for RS-232 Serial Communication
- User's Guide
- Quick Start Guide
- Convenient Carrying Case

Available Accessories

- Fiber Optic Extension Cables
- Vacuum Feedthroughs
- TrueTemp™ Data Acquisition and Graphing Software

Specifications subject to change without notice. Luxtron and Fluoroptic are registered trademarks and TrueTemp is a trademark of Luxtron Corporation. ©2005 Luxtron Corporation. All rights reserved.



Your local Luxtron representative is:

 **LUXTRON**
Direct, Dynamic, Real Time
3033 Scott Blvd., Santa Clara, CA 95054-3316
408.727.1600 tel 408.727.1677 fax
www.luxtron.com