

Sensor Information

Model Name	ON Semiconductor Python 5000
Type	1" progressive scan CMOS
Shutter	Global Shutter
Resolution	2592 x 2048 pixels
Scan Area	12.44 x 9.83
Pixel Size	4.8 μm x 4.8 μm

Data Quality

@ 20 °C, gain = 1, exposure time = 4 msec

Dark Noise (σ)	11 e- typical
Saturation	8400 e- typical
Dynamic Range	57 dB typical
SNR	39 dB typical
Quantum efficiency η	56 % @ 536 nm typical

Acquisition

Resolution	2592 px x 2048 px		
Interface Frame Rate (depends on used interface performance)	Format	Resolution	max. Frame Rate (@ Trigger Mode) ²⁾
	Full Frame	2592 x 2048	23 fps
	Binning 2x2	1296 x 1024	28 fps
	Binning 2x1	1296 x 2048	28 fps
	Binning 1x2	2592 x 1024	28 fps
Acquisition Frame Rate ¹⁾ (Burst Mode)	28 fps $t_{\text{readout}} = 35.3$ msec (max. Res. Full Frame) @ 10 bit		
Pixel Formats	Mono8, Mono10		
Partial Scan	True Partial Scan with increasing Frame Rate on X and Y direction, Region of Interest (ROI) arbitrary Width: minimum 48, increment 16 Height: minimum 2, increment 2		
Adjustable Acquisition Frame Rate	Off or Off or 0,01 ... 2571 Hz		
Acquisition Mode	Continuous, Single Frame and Multi Frame		
Acquisition Status	AcquisitionActive, AcquisitionTrigger Wait		
Exposure Mode	Timed		
Readout Mode	Overlapped, Sequential		

Image Pre-Processing

Analog Controls	Exposure Time (20 μsec ... 1 sec Step Size 1 μsec) Gain (0...18 dB), Offset (0 ... 63 LSB 10 bit)
Gamma Correction	Gamma (0.1 ... 2 available if LUT is enabled)
LUT	Luminance (12 bit)
Color Models	Mono
Color Processing	-
Color Adjustment	-
Color Enhancement	-
Color Tolerance	-
Binning Horizontal	1 or 2
Binning Vertical	1 or 2
Image Flipping	Horizontal, vertical
Defect Pixel Correction	via Defect Pixel List with up to 512 Pixel Coordinates
Fix Pattern Noise Correction	yes

¹⁾ Sensor readout, different from pixel format

²⁾ depends on the used interface

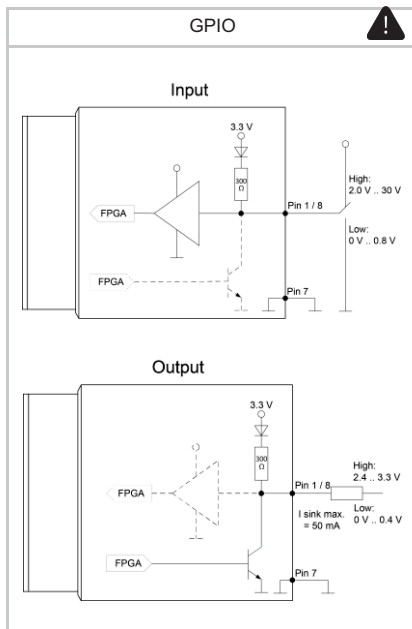
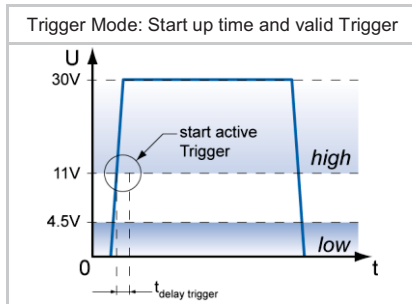
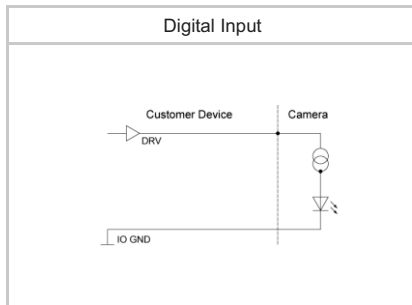
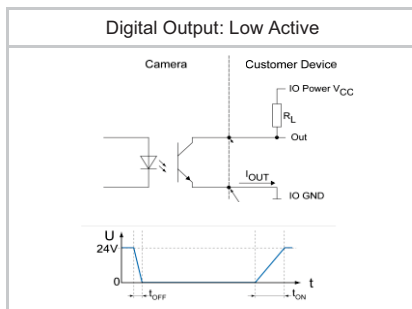

¹⁾ Sensor readout, different from pixel format

Process Synchronization

Trigger Mode	Off (Free Running), On (Trigger)
Trigger Overlap Type	Readout
Trigger Sources	Hardware (Line0,1,2), Software, All, ActionCMD (Action 1) or Off fixed Trigger Delay out of t _{readout} : ¹⁾ 6 µsec @ 10 bit max. Trigger Delay during t _{readout} : ¹⁾ 40 µsec @ 10 bit
Trigger Delay	0 ... 2 sec, Tracking and buffering of up to 256 triggers
External Flash Sync	via Exposure Active t _{delay flash} ≤ 3 µsec, t _{duration} = t _{exposure}

Digital I/Os

Lines	Input: Line 0, Output: Line3, GPIO: Line 1, Line 2
Output Sources	Off, ExposureActive, Timer1, ReadoutActive, UserOutput 1-3 and TriggerReady
Line Debouncer	Low and high signal separately selectable Debouncing Time 0 ... 5 msec, Step Size: 1 µsec

Memory

Image Buffer	122 MB 8 Images (Trigger Mode) / 1 Image (Free Running Mode)
Non-volatile Memory	128 kb

Network Interface Data

Interface	Gigabit Ethernet 1000BASE-T 1000 Mbits/sec Fast Ethernet 100 BASE-T 100 Mbits/sec
Ethernet IP Configuration	Persistent IP, DHCP, LLA
Packet Size	576 ... 9000 Byte, Jumbo Frames supported

GigE Vision® Features

Events	DeviceTemperatureStatusChanged, EventLost, ExposureEnd, ExposureStart, FrameEnd, FrameStart, FrameTransferSkipped, Error, GigE VisionHeartbeatTimeOut, Line0..3 FallingEdge, Line0..3 RisingEdge, PrimaryApplicationSwitch, TransferBufferFull, TransferBufferReady, TriggerOverlapped, TriggerReady, TriggerSkipped
Transmission via Asynchronous Message Channel	
Action CMD	yes, Action 1 for Trigger
Frame Counter	up to 2 ³²
Payload Size	0 ... 10617032 Byte
Timestamp	64 bit, resolution in nsec, increment = 8
Packet Delay	0 .. 2 ³² - 1 nsec
Packet Resend	Resend Buffer: 81 MB (8 Images)
GigE Vision	v2.0 (v1.2 backward compatible)

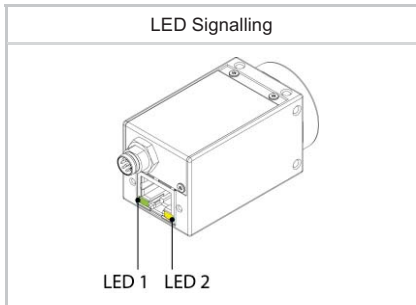
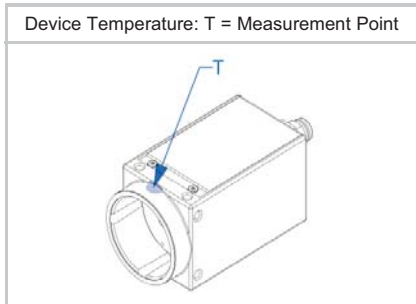
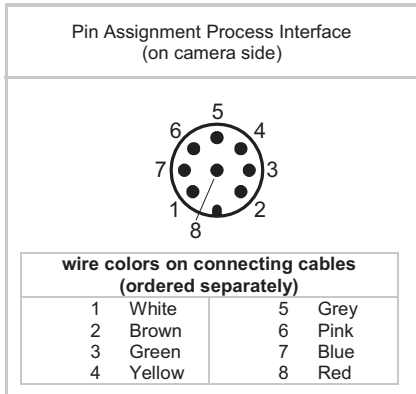
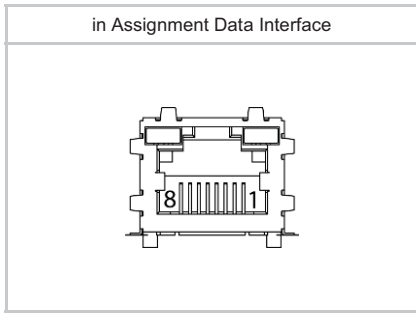

Interfaces and Connectors

Data and Power Interface	Gigabit Ethernet	Transfer Rate	1000 Mbits/sec
	Fast Ethernet	Transfer Rate	100 Mbits/sec
	Connector:	8P8C Modular Jack (RJ45), screw lock type	
Process Interface	Assignment:	1 - MX1+	2 - MX1-
		3 - MX2+	4 - MX3+
		5 - MX3-	6 - MX2-
		7 - MX4+	8 - MX4-
	Connector:	M8/8-pin (SACC-DSI-M8MS-8CON-M8-L180)	
	Assignment:	1 - GPIO (Line2)	2 - Power Vcc
		3 - IN1 (Line0)	4 - GND IN1
		5 - Power VCC OUT	6 - OUT1 (Line3)
	7 - GND (Power, GPIO)	8 - GPIO (Line1)	

Caution



* Note GPIOs: Ground loops are to be avoided and can lead to destruction of the device.

Optical Data

Lens Mount	C-Mount
Optical Filter	-

Mechanical Data

Housing	Zinc die casting, nickel-chrome-plated, IP40 (with mounted lens and GigE cable)
---------	---

Dimensions

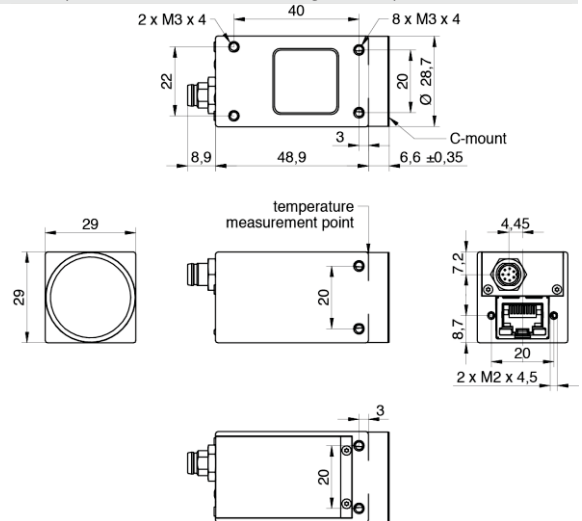

Weight	120 g
--------	-------

Environmental Data

Storage Temperature	-10 °C ... + 70 °C
Operating Temperature	+5 °C ... +65 °C @ T = Measurement Point or +5 °C ... +75 °C @ internal Temperature Sensor Ambient temperature above 30 °C requires heat dissipation measures.
Int. Temperature Sensor	yes, accuracy: ±1 °C (typ) 0 °C ... +85 °C
Humidity	10 % ... 90 % non-condensing

LED Signalling

LED	Green flash	RX active
	Green	Link ON
	Yellow	Error
	Yellow flash	TX active

Electrical Data

Power Supply (ext.)	VCC: 12 ... 24 V DC \pm 20% I: 121 ... 243 mA
Power over Ethernet	Class 0 device VCC: 36 ... 57 V DC I: 72 mA @ 48 VDC
Power Consumption	approx. 2.9 W @ 12VDC and 23 fps approx. 3.5 W @ 48 VDC (PoE) and 23 fps (Factory Setting "Default")
Digital Input	Optocoupler $U_{IN(low)}$: 0.0 ... 4.5 VDC $U_{IN(high)}$: 11.0 ... 30.0 VDC I_{IN} : 3.0 ... 10.0 mA min. Impulse Length: 2.0 μ sec
Digital Output	Optocoupler U_{EXT} : 5 ... 30 V DC I_{OUT} : max. 50 mA t_{ON} = typ. 3 μ sec t_{OFF} = typ. 40 μ sec
GPIO	direct, without optocoupler
GPIO used as Input:	$U_{IN(low)}$: 0.0 ... 0.8 VDC $U_{IN(high)}$: 2.0 ... 30.0 VDC min. Impulse Length: 2.0 μ sec
GPIO used as Output:	$U_{Out(low)}$: 0.0 ... 0.4 VDC ($I_{sink\ max}$: 50 mA) $U_{Out(high)}$: 2.4 ... 3.3VDC (I_{max} : 1 mA)
Caution 	* The General Purpose I/Os (GPIOs) are not potential-free and do not have an overrun cut-off. Incorrect wiring (overvoltage, undervoltage or voltage reversal) can lead to defects in the electronic system. Ground loops are to be avoided and can lead to destruction of the device.

Conformity

Conformity	CE, RoHS, REACh, KC
KC Registration No. / Date	MSIP-REI-BkR-VCXG-53M / 02.05.2017
MTBF	62 years @ T = 45 °C / 40 years @ T = 60 °C T = Measurement Point

GenICam™ Features

Short Exposure Range	-
Timer	Timer Selector: Timer 1 TimerTriggerSource: Line0, SoftwareTrigger, ExposureStart, ExposureEnd, FrameTransferSkipped, TriggerSkipped, Action 1 and Off TimerDelay: 0 μ sec ... 2 sec, Step Size: 1 μ sec TimerDuration: 4 μ sec ... 2 sec, Step Size: 1 μ sec
Counter	Counter Selector: Counter 1, Counter 2 CounterValue: 0 ... 65535 Counter Event Source: Counter1End or Counter2End, ExposureActive, FrameTransferSkipped, FrameTrigger, TriggerSkipped and Off Counter Reset Source: Counter1End, Counter2End, Line0 and Off
Sequencer	Sequencer Characteristics: up to 128 sets, up to 4 possible pathes for triggered set transitions, 6 trigger sources: Counter1End, Counter2End, ExposureActive, Line0, ReadoutActive, Timer1End Sequencer Parameters for Exposure, Gain, Trigger, ROI and Output: ExposureTime, CounterDuration, CounterEventActivation, CounterEventSource, CounterResetSource, ExposureMode, ExposureTime, Gain, Height, OffsetX, OffsetY, TriggerMode, UserOutputValue, UserOutputValueAll, Width

GenICam™ Features

User Sets	Factory Settings: UserSet0 (read only) Freely Programmable: UserSet1, UserSet2, UserSet3 Parameters: any user definable Parameter
Acquisition Abort	Delay up to 35.3 msec
Chunk Data	yes, Chunk Selector: Binning, Black Level, DeviceTemperature, ExposureTime, FrameID, Gain, Height, Image, ImageControl, LineStatusAll
Device Temperature	InHouse Event generation for Normal to High, High to Exceeded and Exceeded to Normal Exceeded (no image transfer) = max. internal temperature sensor + 1 °C
Device Link Throughput Limit	yes, up to max. Device Link Speed
SFNC Version	v2.3

Factory Settings after Start-Up

Trigger Mode	Off (Free Running)
Analog Controls	Exposure Time: 4 msec, Gain: 0 dB, Offset: 0
Pixel Format	Mono8
Partial Scan	Off
Acquisition Frame Rate	Off
Timer/Counter/Sequencer	Off
Defect Pixel Correction	ON
Fixed Pattern Noise Correction	ON
Digital Input	Line0, invert = false
Digital Output	Line3, invert = false, line source = Off
GPIO 1/2	Line1, Line2, invert = false, LineMode = Input
TriggerSource	All

Partial Scan @ FullFrame, min Exposure, Mono8 or BayerRG8

	Resolution	max. fps acquisition	max. fps interface ²⁾
Full HD	1920 x 1080	66	60
SXGA	1280 x 1024	90	90
XGA	1024 x 768	134	134
SVGA	800 x 600	191	191
VGA	640 x 480	239	239
CIF	352 x 288	377	377
QCIF	176 x 144	661	661
LineScan	2592 x 2048	28	23
	2592 x 1024	56	46
	2592 x 512	109	93
	2592 x 256	250	245
	2592 x 128	391	373
	2592 x 64	683	683
	2592 x 32	1090	1090
	2592 x 16	1550	1550
	2592 x 8	1967	1967
	2592 x 4	2270	2270
2592 x 2	2271	2271	
2592 x 1	-	-	

²⁾ depends on the used interface

Distribution in the UK & Ireland



**Characterisation,
Measurement &
Analysis**

Lambda Photometrics Limited
Lambda House Batford Mill
Harpenden Herts AL5 5BZ
United Kingdom
E: info@lambdaphoto.co.uk
W: www.lambdaphoto.co.uk
T: +44 (0)1582 764334
F: +44 (0)1582 712084