

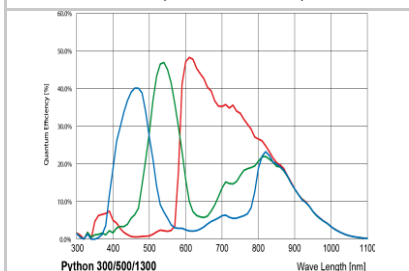

Sensor Graph: Relative Response

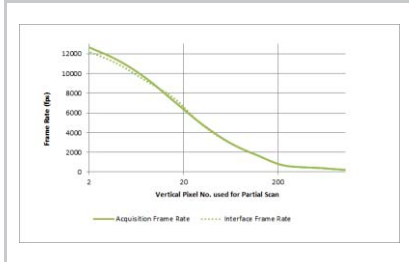

Frame Rates / Partial Scan  
(Measured at Mono8/BayerRG8-Format)



Digital Output: High Active

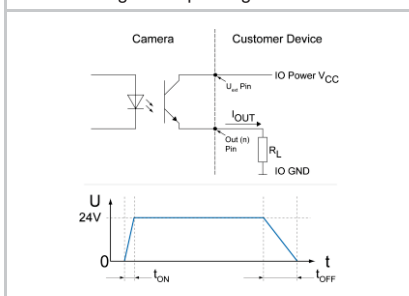

<sup>1)</sup> Sensor readout, different from pixel format

<sup>2)</sup> depends on the used interface



## Sensor Information

Model Name	ON Semiconductor Python 1300
Type	1/2" progressive scan CMOS
Shutter	Global Shutter
Resolution	1280 x 1024 pixels
Scan Area	6.14 mm x 4.92 mm
Pixel Size	4.8 μm x 4.8 μm

## Data Quality

@ 20 °C, gain = 1, exposure time = 4 msec

Dark Noise ( $\sigma$ )	10 e- typical
Saturation	7000 e- typical
Dynamic Range	56.5 dB typical
SNR	38.5 dB typical
Quantum efficiency $\eta$	40 % @ 465 nm, 43 % @ 536 nm, 46 % @ 631 nm typical

## Acquisition

Resolution	1280 px x 1024 px		
Interface Frame Rate (depends on used interface performance)	Format	Resolution	max. Frame Rate (@ Trigger Mode) <sup>2)</sup>
	Full Frame	1280 x 1024	222 fps
	Binning 2x2	640 x 512	222 fps
	Binning 2x1	640 x 1024	222 fps
	Binning 1x2	1280 x 512	222 fps
Acquisition Frame Rate <sup>1)</sup>	222 fps   $t_{\text{readout}} = 4.5 \text{ msec}$ (max. Res. Full Frame) @ 10 bit		

Pixel Formats	BayerRG8, BayerRG10 Mono8, Mono10, RGB8, BGR8
Partial Scan	True Partial Scan with increasing Frame Rate on X and Y direction, Region of Interest (ROI) arbitrary Width: minimum 24, increment 8 Height: minimum 4, increment 4
Adjustable Acquisition Frame Rate	Off or 0.01 ... 13513 Hz
Acquisition Mode	Continuous, Single Frame and Multi Frame
Acquisition Status	AcquisitionActive, AcquisitionTrigger Wait
Exposure Mode	Timed
Shutter Mode	-
Readout Mode	Overlapped, Sequential

## Image Pre-Processing

Analog Controls	Exposure Time (20 μsec ... 1 sec   Step Size 1 μsec) Gain (0...12 dB), Offset (0 ... 63 LSB   10 bit)
Gamma Correction	Gamma (0.1 ... 2   available if LUT is enabled)
LUT	Luminance (12 bit)
Color Models	Mono, Raw Bayer, RGB and BGR
Color Processing	Integrated color processor for high quality color calculation
Color Adjustment	Manual White Balance Automatic White Balance (Once or Continuous)
Color Enhancement	Color Transformation to sRGB color space by optimized Matrix for 6500 K, 3000 K Lightsource or User defined Matrix
Color Tolerance	-
Binning Horizontal	1 or 2
Binning Vertical	1 or 2
Image Flipping	Horizontal, vertical
Defect Pixel Correction	via Defect Pixel List with up to 512 Pixel Coordinates
Fix Pattern Noise	yes
Correction	

### Digital Output: Low Active

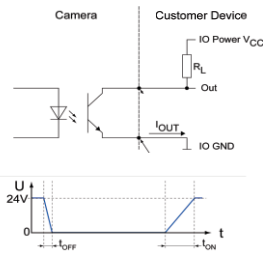

### Digital Input

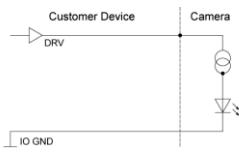

### Trigger Mode: Start up time and valid Trigger

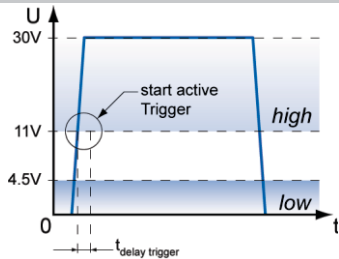

### GPIO

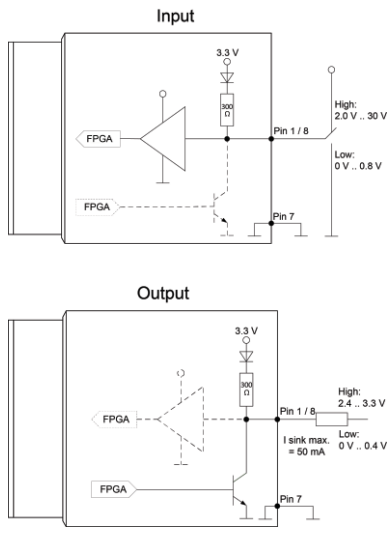

## Process Synchronization

Trigger Mode	Off (Free Running), On (Trigger)
Trigger Overlap Type	Readout
Trigger Sources	Hardware (Line0,1,2), Software, All or Off fixed Trigger Delay out of t <sub>readout</sub> : <sup>1)</sup> 4 μsec @ 10 bit max. Trigger Delay during t <sub>readout</sub> : <sup>1)</sup> 8 μsec @ 10 bit
Trigger Delay	0 ... 2 sec, Tracking and buffering of up to 256 triggers
External Flash Sync	via Exposure Active t <sub>delay flash</sub> ≤ 3 μsec, t <sub>duration</sub> = t <sub>exposure</sub>

## Digital I/Os

Lines	Input: Line 0, Output: Line3, GPIO: Line 1, Line 2
Output Sources	Off, ExposureActive, Timer1, ReadoutActive, UserOutput 1-3 and TriggerReady
Line Debouncer	Low and high signal separately selectable Debouncing Time 0 ... 5 msec, Step Size: 1 μsec

## Memory

Image Buffer	477 MB 127 Images (Trigger Mode) / 1 Image (Free Running Mode)
Non-volatile Memory	128 kb

## Interface Data

Interface	USB3.0 (5000 Mbits/sec)
USB Vendor ID / Product ID	0x2825 / 0x13A

## USB 3 Vision® Features

Events	DeviceTemperatureStatusChanged, EventLost, ExposureEnd, ExposureStart, FrameEnd, FrameStart, FrameTransferSkipped, Line0..3 FallingEdge, Line0..3 RisingEdge, TransferBufferFull, TransferBufferReady, TriggerOverlapped, TriggerReady, TriggerSkipped
Transmission via Asynchronous Message Channel	
Frame Counter	up to 2 <sup>32</sup>
Payload Size	0 ... 3932360 Byte
Timestamp	64 bit, resolution in nsec, increment = 10
USB Vision	v1.0.1

<sup>1)</sup> Sensor readout, different from pixel format

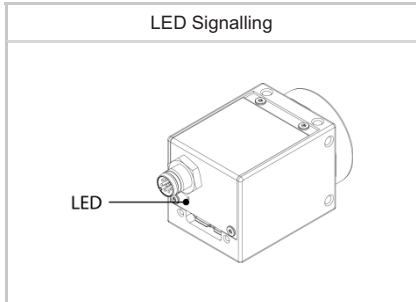
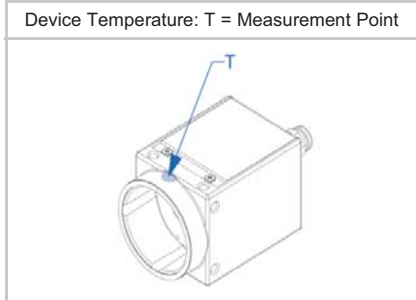
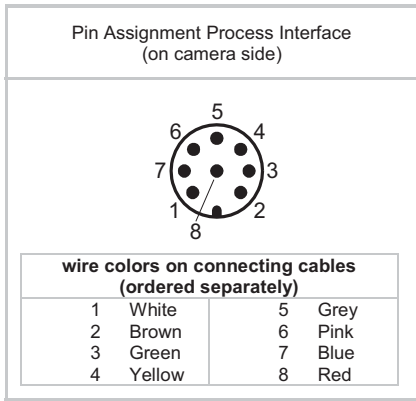
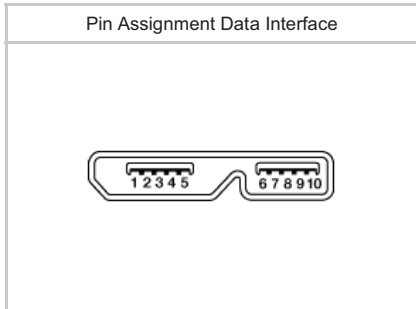

## Interfaces and Connectors

Data and Power Interface	USB 3.0	Transfer Rate	5000 Mbits/sec
	USB 2.0	Transfer Rate	480 Mbits/sec
	Connector:		USB 3.0 Micro B
Process Interface	Connector:	M8/8-pin (SACC-DSI-M8MS-8CON-M8-L180)	
	Assignment:	1 - GPIO (Line2)	5 - Power VCC
		2 - not connected	OUT1
		3 - IN1 (Line0)	6 - OUT1 (Line3)
		4 - GND IN1	7 - GND GPIO
			8 - GPIO (Line1)

Caution

\* Note GPIOs: Ground loops are to be avoided and can lead to destruction of the device.

## Optical Data

Lens Mount	C-Mount
Optical Filter	IR cut filter

## Mechanical Data

Housing	Zinc die casting, nickel-chrome-plated, IP40 (with mounted lens and USB 3.0 cable)
---------	--

Dimensions

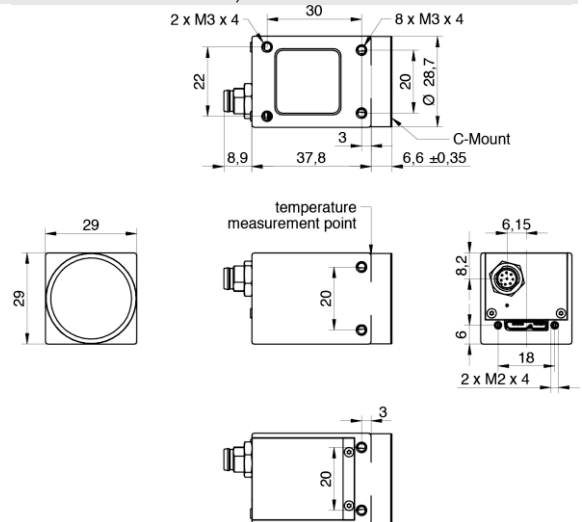

Weight	90 g
--------	------

## Environmental Data

Storage Temperature	-10 °C ... +70 °C
Operating Temperature	+5 °C ... +65 °C @ T = Measurement Point or +5 °C ... +72 °C @ internal Temperature Sensor Ambient temperature above 35 °C requires heat dissipation measures.
Int. Temperature Sensor	yes, accuracy: ±1 °C (typ) 0 °C ... +85 °C
Humidity	10 % ... 90 % non-condensing

## LED Signalling

LED	Green flash	Power on, no link active
	Green	Link active USB 3.0
	Red	Error or Link active USB 2.0
	Yellow	Sensor Readout activity
	Red flash	Update

## Electrical Data

Power Supply	bus powered via USB3.0 interface
Power Consumption	approx. 2.6 W @ 222 fps (Factory Setting "Default")
Digital Input	Optocoupler $U_{IN(low)}$ : 0.0 ... 4.5 VDC $U_{IN(high)}$ : 11.0 ... 30.0 VDC $I_{IN}$ : 3.0 ... 10.0 mA min. Impulse Length: 2.0 $\mu$ sec
Digital Output	Optocoupler $U_{EXT}$ : 5 ... 30 V DC $I_{OUT}$ : max. 50 mA $t_{ON}$ = typ. 3 $\mu$ sec $t_{OFF}$ = typ. 40 $\mu$ sec
GPIO	direct, without optocoupler
GPIO used as Input:	$U_{IN(low)}$ : 0.0 ... 0.8 VDC $U_{IN(high)}$ : 2.0 ... 30.0 VDC min. Impulse Length: 2.0 $\mu$ sec
GPIO used as Output:	$U_{Out(low)}$ : 0.0 ... 0.4 VDC ( $I_{sink\ max}$ : 50 mA) $U_{Out(high)}$ : 2.4 ... 3.3VDC ( $I_{max}$ : 1 mA)
Caution 	* The General Purpose I/Os (GPIOs) are not potential-free and do not have an overrun cut-off. Incorrect wiring (overvoltage, undervoltage or voltage reversal) can lead to defects in the electronic system. Ground loops are to be avoided and can lead to destruction of the device.

## Conformity

Conformity	CE, RoHS, REACh, KC
KC Registration No. / Date	MSIP-REI-BkR-VCXU13M / 18.04.2017
MTBF	68 years @ T = 45 °C / 44 years @ T = 60 °C T = Measurement Point

## GenICam™ Features

Short Exposure Range	-
Timer	Timer Selector: Timer Selector: Timer 1 TimerTriggerSource: Line0, SoftwareTrigger, ExposureStart, ExposureEnd, FrameTransferSkipped, TriggerSkipped, Off TimerDelay: 0 $\mu$ sec ... 2 sec, Step Size: 1 $\mu$ sec TimerDuration: 4 $\mu$ sec ... 2 sec, Step Size: 1 $\mu$ sec
Counter	Counter Selector: Counter 1, Counter 2 CounterValue: 0 ... 65535 Counter Event Source: Counter1End or Counter2End, ExposureActive, FrameTransferSkipped, FrameTrigger, TriggerSkipped and Off Counter Reset Source: Counter1End, Counter2End, Line0 and Off
Sequencer	Sequencer Characteristics: up to 128 sets, up to 4 possible pathes for triggered set transitions, 6 trigger sources: Counter1End, Counter2End, ExposureActive, Line0, ReadoutActive, Timer1End Sequencer Parameters for Exposure, Gain, Trigger, ROI and Output: ExposureTime, CounterDuration, CounterEventActivation, CounterEventSource, CounterResetSource, ExposureMode, ExposureTime, Gain, Height, OffsetX, OffsetY, TriggerMode, UserOutputValue, UserOutputValueAll, Width

## GenICam™ Features

User Sets	Factory Settings: UserSet0 (read only) Freely Programmable: UserSet1, UserSet2, UserSet3 Parameters: any user definable Parameter
Acquisition Abort	Delay up to 4.5 msec
Chunk Data	yes, Chunk Selector: Binning, Black Level, DeviceTemperature, ExposureTime, FrameID, Gain, Height, Image, ImageControl, LineStatusAll
Device Temperature	InHouse Event generation for Normal to High, High to Exceeded and Exceeded to Normal Exceeded (no image transfer) = max. internal temperature sensor + 1 °C
Device Link Throughput Limit	yes, up to max. Device Link Speed
SFNC Version	v2.3

## Factory Settings after Start-Up

Trigger Mode	Off (Free Running)
Analog Controls	Exposure Time: 4 msec, Gain: 0 dB, Offset: 0
Pixel Format	BayerRG8
Partial Scan	Off
Acquisition Frame Rate	Off
Timer/Counter/Sequencer	Off
Defect Pixel Correction	ON
Fixed Pattern Noise Correction	ON
Digital Input	Line0, invert = false
Digital Output	Line3, invert = false, line source = Off
GPIO 1/2	Line1, Line2, invert = false, LineMode = Input
TriggerSource	All

## Partial Scan @ FullFrame, min Exposure, Mono8 or BayerRG8

	Resolution	max. fps acquisition	max. fps interface <sup>2)</sup>
SXGA	1280 x 1024	222	222
XGA	1024 x 768	366	366
SVGA	800 x 600	587	587
VGA	640 x 480	894	893
CIF	352 x 288	2357	2357
QCIF	176 x 144	4305	4305
LineScan	1280 x 1024	222	222
	1280 x 512	438	437
	1280 x 256	804	804
	1280 x 128	1602	1602
	1280 x 64	2875	2778
	1280 x 32	4781	4771
	1280 x 16	7141	7080
	1280 x 8	9504	9301
	1280 x 4	11341	10833
	1280 x 2	12645	10624
	1280 x 1		-

<sup>2)</sup> depends on the used interface

Distribution in the UK & Ireland



**Characterisation,  
Measurement &  
Analysis**

**Lambda Photometrics Limited**  
Lambda House Batford Mill  
Harpenden Herts AL5 5BZ  
United Kingdom

**E: info@lambdaphoto.co.uk**  
**W: www.lambdaphoto.co.uk**  
**T: +44 (0)1582 764334**  
**F: +44 (0)1582 712084**