

## CS548 System Overview

### Summary

The CS548 system is a set of tools used to measure power electronic systems from individual transistors to full bridges. By using linked CS548's the number of channels can be extended to 16. Fiber linked digitizers extend the CS548 out into the safety cage, and allow measurements up to 100m apart on large structures such as HV pylons, trains or planes. The ADC at the measurement source improves noise, offset and linearity over conventional oscilloscopes. Remote digitizers measuring voltage, current and saturated voltage are supported. Pods measuring high resolution voltage, current and temperature provide continuous capture at lower rate. Isolated Digital Input pods are used for measuring digital signals. Isolated Digital Output pods can be used with Pulse Builder to make arbitrary pulse trains, including double pulse and PWM. An isolated signal generator is used for Frequency Response Analysis (FRA).

### Isolation Concept

The CS548 has fiber optic isolated digitizers both internal to the unit, and also external, via QSFP sockets on the front panel. In both cases the same Active Optical Cable (AOC) is used for isolation. A Gbit switch is used to choose between the internal AOC and the external AOC. The fiber isolation is used to achieve 100 dB CMRR at 50 MHz.

The CS548 uses a 14 bit 500 MSPS ADC to digitize the signal close to the input. Once digitized the **digital signal** is transferred through the AOC to the FPGA which does storage and communications. Noise, offset and distortion are minimized. The AOC may be from 1 – 50m long. The CS548 typical rms noise to full range ratio, a measure of dynamic range, is 1 part 5,300. Others are at least 5x worse.

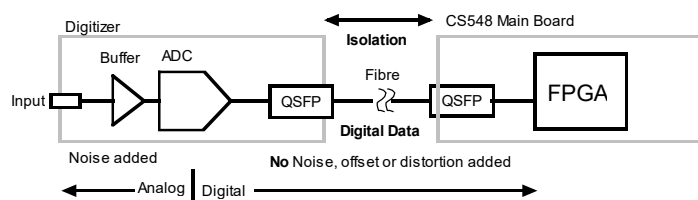

Other oscilloscopes use a fiber connected probe, a modulator/demodulator approach to transfer **analog signals** over the fiber. The whole chain through to the ADC inside the oscilloscope is analog, and has worse noise, offset and distortion as a result.

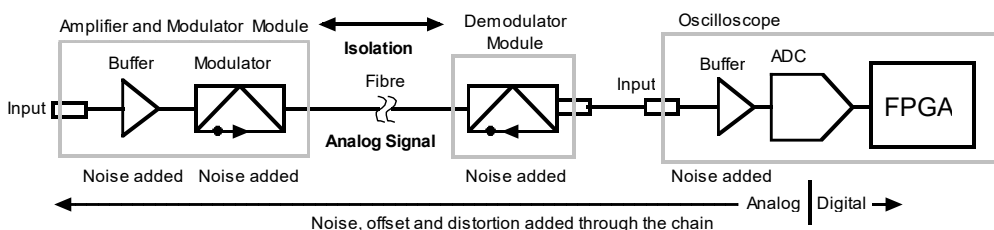

Comparing: measurements with 200 MHz bandwidth. The CS548 is total system. Others are just the probe, and **don't** include the oscilloscope.

Parameter	Range	Noise (rms)	Rms noise to range ratio, 1 part in	DC gain accuracy	0V accuracy, $\pm 1V$ range or so
CS548	$\pm 800mV$	0.3 mV	5,300	$< \pm 0.15\%$	$< \pm 300uV$ (0.8V range)
CS548	$\pm 8000mV$	3mV	5,300	$< \pm 0.15\%$	$< \pm 3mV$ (8V range)
PMK Firefly	$\pm 1000mV$	2 mV	1,000	$< \pm 2\%$	$< \pm 1.5mV$
Lecroy DL03-ISO	$\pm 1000mV$	4.49 mV	445	$< \pm 1.5\%$	Not Specified
TIVP02	$\pm 320 mV$	1.46 mV	438	$< \pm 3\%$	Not Specified
TIVP02	$\pm 5000 mV$	48 mV	208	$< \pm 3\%$	Not Specified
R&S RT-ZISO-B902	$\pm 1000mV$	7.27 mV	275	$< \pm 1.5\%$	$< \pm 7 mV$

# Measurement Concept

The CS548 system is designed to measure signals on power electronics systems. As such it needs to operate with large common mode voltages between real ground and the probe common. In addition, the common mode voltage may be changing rapidly – we allow up to 100V/ns. The common mode change must not affect the measurement being made. This is known as Common Mode Rejection.

It is useful to understand the measurement concept as illustrated in the half bridge below:

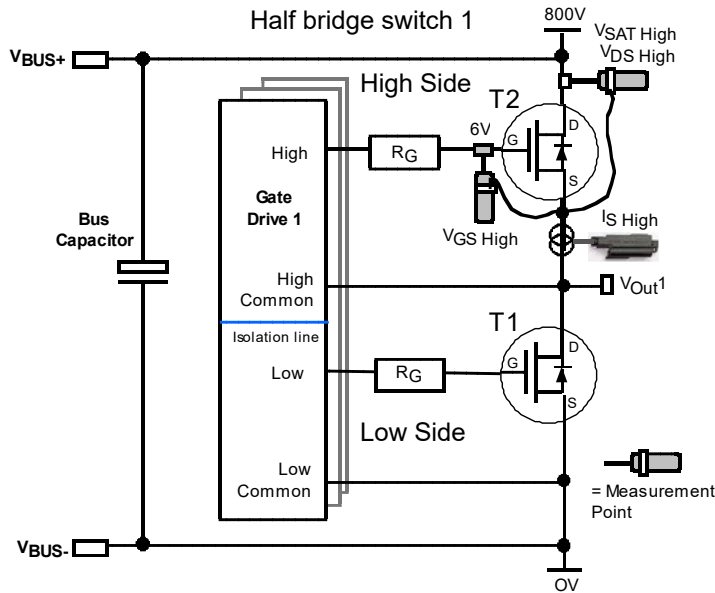

The half bridge uses two transistors T1 and T2 to switch between VBUS- (T1 on) and VBUS+ (T2 on).

As a result, Vout outputs a rectangular wave (usually PWM).

T2 is the High Side transistor. Measurements of VGS, VDS and IS on T2 are referred to the T2 source (S). The source is connected to Vout and rapidly transition between 0V and 800V in this example. So, the measurement of these signals includes a large common mode voltage that is changing quickly.

The switching waveforms illustrate this point:

This is Vout, which switches between 0V and 800V less the ON transistor saturated voltage Vsat.

This is VDS, and IS for the top transistor, T2. Signals are referred to the source (S) which is also Vout. When Vout = 800V, T2 is On, and VDS = Vsat. At this time the current Is is at its peak.

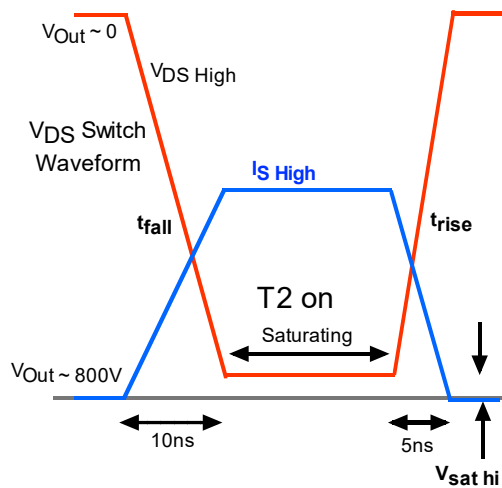
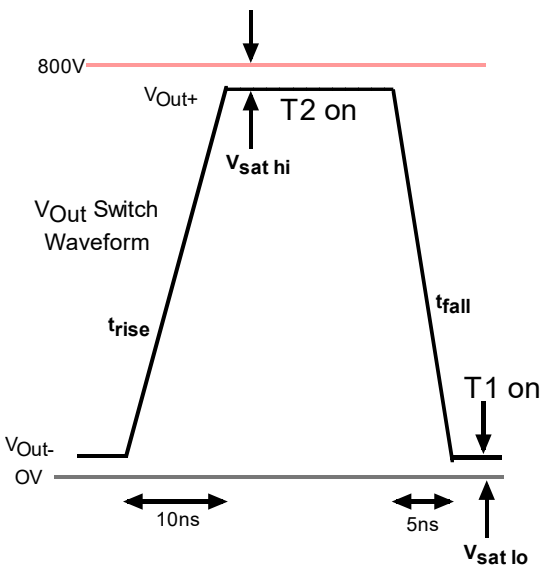

During switch edge period:  
 $P_{switch} = V_{DS\ hi} \times I_{S\ High}$   
 $E_{switch} = \int V_{DS\ hi} \times I_{S\ High} dt$

During saturation period:  
 $P_{Conduction} = V_{sat\ hi} \times I_{S\ High}$   
 $E_{conduction} = \int V_{DS\ hi} \times I_{S\ High} dt$

Applying this concept to the parts to be discussed:

- The CS548, and the CS1200 voltage digitizer measure **VDS** and **VGS**.
- The CS1133 Vsat probe and CS1203 Vsat digitizer measure **Vsat**.
- The CS1201 current digitizer measures **IS**
- The CS1202 loss digitizer measures all of these, and **Pswitch** and **Eswitch** as well.

# System Concept

## Standard Use



The CS548 is an isolated channel 200MHz BW oscilloscope using four industry standard passive probes. To keep noise down each channel has just two ranges, and there is no offset control as the 14 bit converter offers enough dynamic range. The CS548 is supplied with 1/10x probes (covering  $\pm 800\text{mV}$  to  $\pm 80\text{V}$ ) and 100x probes (covering  $\pm 80\text{V}$  and  $\pm 800\text{V}$ ). An alternate to the 100x probe is 200x (covering  $\pm 160\text{V}$  and  $\pm 1600\text{V}$ ). Other probe dividers are available. The CS548 is rated for operation with common mode voltages in the range  $\pm 2000\text{V}$ , and offers CMRR  $>100\text{ dB}$  at 50MHz at the input. The Signal Generator is rated for  $600\text{V}_{\text{CM}}$ .

## The CS548 is expandable.

The expansion can be carried out using these pathways:

## Channels

Each 4 channel CS548 can be linked with up to three other CS448's to offer 16 channels, connecting Link Out to Link In on the CS548 rear panel. All oscilloscopes are time aligned, and share trigger data. The application treats the combination as one oscilloscope:



## Pods

Each CS548 has two Pod sockets. Any type of pod can be used in each socket.

These types of pods are available now:

- CS1301 Isolated digital input pods (4 In), used to display or trigger off digital inputs
- CS1302 Isolated digital in/out pods (4 Out, 1 In) used to control digital signals or gate drives. The Pulse Builder application is used to make arbitrary pulse trains, double/triple pulse outputs, and PWM. The input is available as a standard digital input. Pulse builder setup and outcome is shown below:

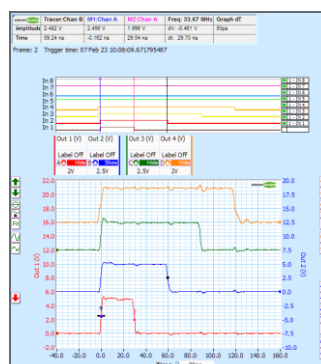
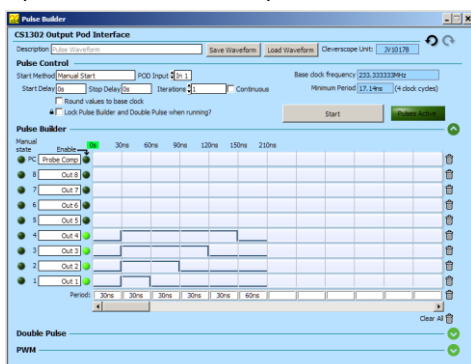
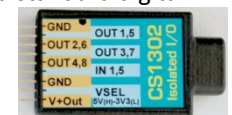

These types of pods are coming Q1 2025:

- CS1303 measurement hub allows up to 4 measurement pods to be connected to one CS548 Pod port.
- CS1304 Isolated Voltage Measurement Pod, with 16 bit precision at >100 KSPS to log lower bandwidth voltage signals. Variants that cover  $\pm 1, 10, 100, 1000$  and  $2000V$  will be available.
- CS1305 Isolated Current Measurement Pod for 50mV current sensors, with 16 bit precision at >100 KSPS to log lower bandwidth current signals.
- CS1306 Isolated Temperature Measurement Pod, for use with K type or PT100 temperature sensors. 16 bit precision.
- CS1310 CAN controller to monitor or stimulate CAN messages, including triggering. This will be used with the EV module testing (Q2 2025).

The CS1303-6 connection concept is shown below:

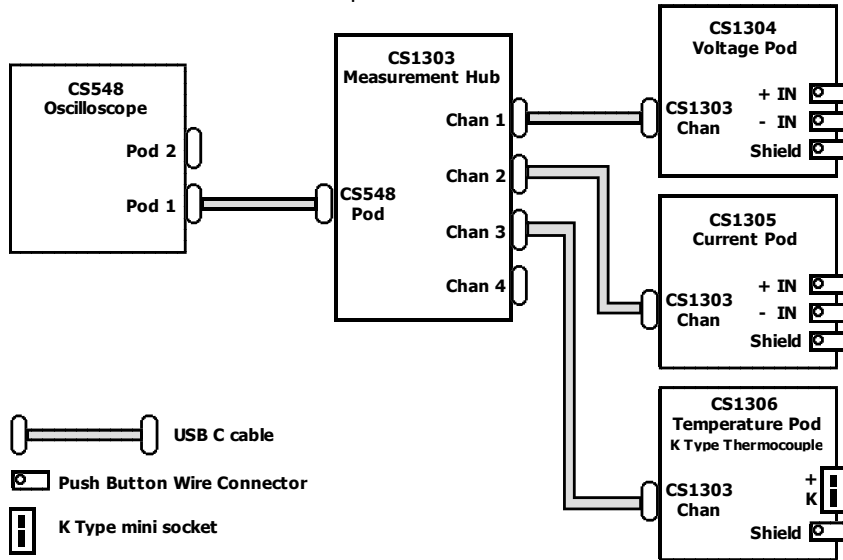

Using two pod sets, with 4x Voltage, and 4x Current a complete 3 phase 100 kHz bandwidth (2000<sup>th</sup> harmonic) power/energy analyser with logging will be supported.

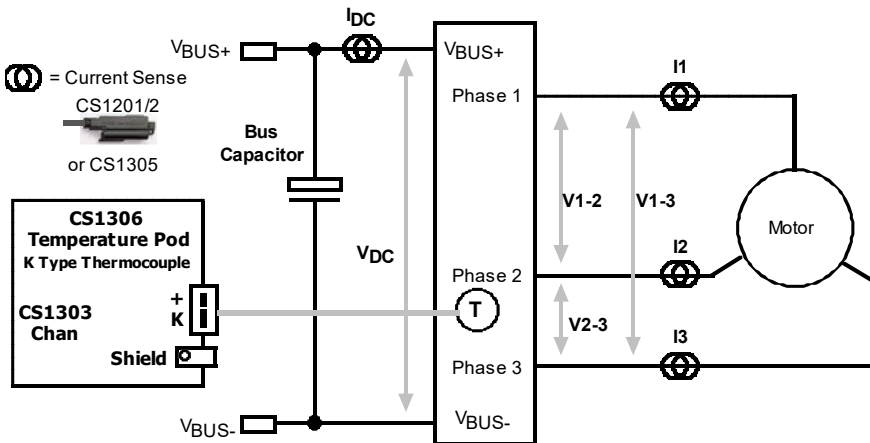

The current sensor can be either a CS1201 using a CS1501 current sensor, or a CS1305 using standard 50mV current shunts such as the Riedon RSA range.

Riedon RSA Current Sensors

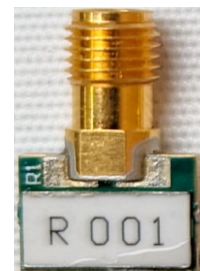

CS1501 PCB mounted Current Sensor

# Remote Digitizers

Cleverscope remote digitizers are variants of the digitizer used inside the CS548, repackaged for remote use. They use an AOC which plugs into the Remote QSFP sockets on the front of the CS548. They include 2 x 21700 lithium cells for isolated power.

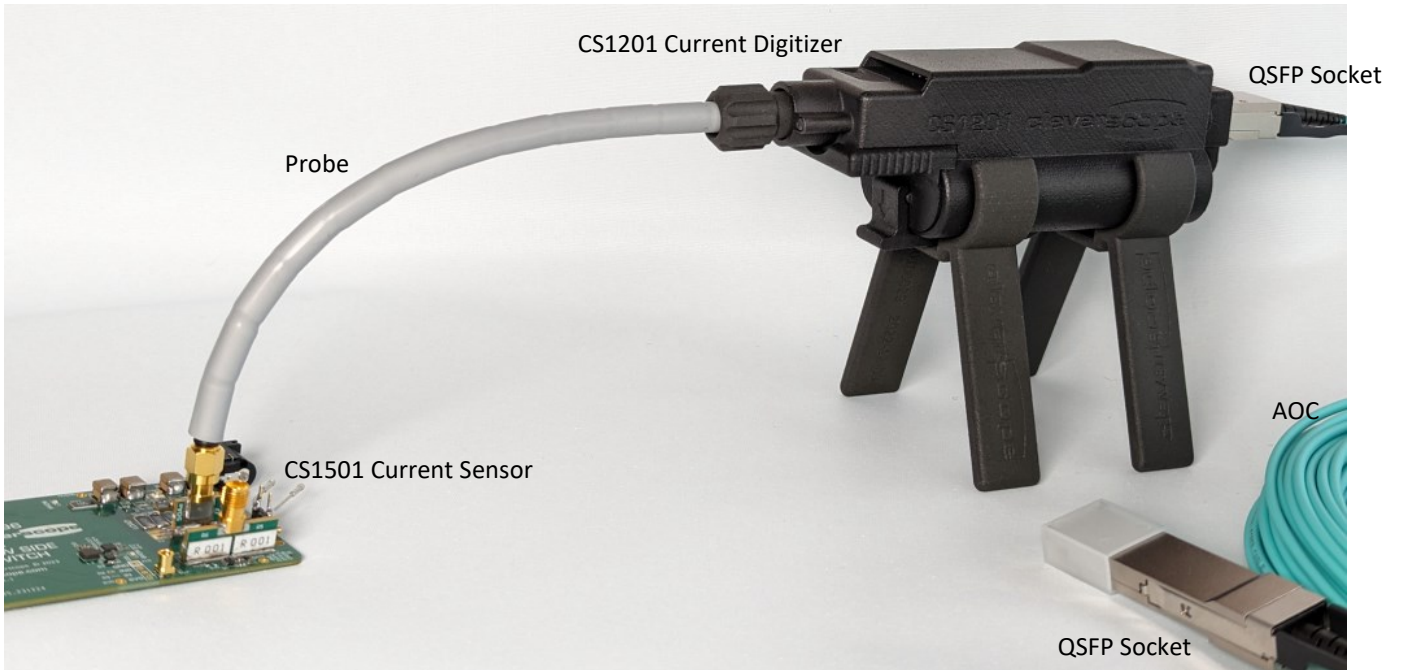

## Remote Digitizers available now:

- CS1200 Voltage Digitizer (VD)**  
 Identical to the CS548 digitizer in ranges and noise. It can use standard probes, or a shorter probe tip for better CMRR.

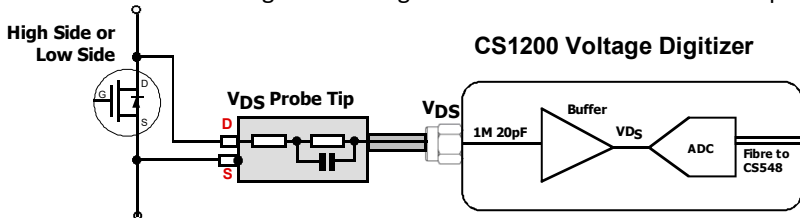

- CS1201 Current Digitizer (CD)**  
 For use with the CS1501 shunt resistor current sensor (see picture, above). The CS1501 inserts about 20 pΩ into the current path, and has a bandwidth of around 1 GHz. It has two ranges - ±64mV and ±640mV.

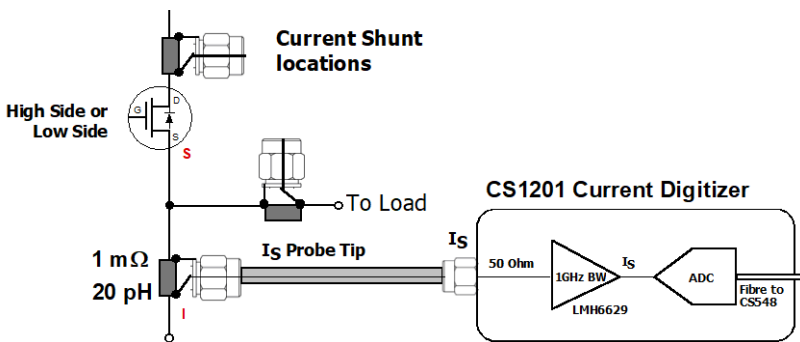

CS1501 Current Sensor

These current shunts are available:

Current Sensor	Resistance	Range	Useable resolution	Max current (for DPT)	Duty Cycle / On period
CS1501	1 mΩ	±64mV	64 mA	±64A	50% Square Wave
CS1501	1 mΩ	±640mV	640 mA	±640A	100us every 20 msec min

# Remote Digitizer available Q1 2025

## CS1202 5GSPS Transistor Digitizer (TD)

The TD provides a complete transistor measurement system in one digitizer. In step 1, we have already built and shown a prototype CS1202 at APEC/PCIM that performs the VSAT, VDS, IS, PSW, and ESW measurements. VSAT is the transistor saturated ON voltage, and is clipped at 15V. Below 15V the saturated voltage is measured with mV precision. The rising or falling edge in a switching system may have non-linearity's caused by resonances in the gate drive, non-linearity's in the turn on/off characteristic of the transistor, and resonances in the power flow loop. These will not be seen by a slower sampling system, but will be correctly incorporated into the PSW and ESW values by the analog multiplier and integrator in the diagram below.

The TD has two use cases:

1. Double Pulse test, with 5 GSPS bandwidth measurement of the 2<sup>nd</sup> (Turn off) and 3<sup>rd</sup> (Turn on) pulse edges.
2. Long duration capture (up to 125 ms) of Vs, Vsat, Vgs and Is, and also the peak Psw and Esw for every pulse, allowing multi cycle switching and conduction loss measurement, with high bandwidth sampling on periodic edges.

### CS1202 5GSPS Transistor Digitizer

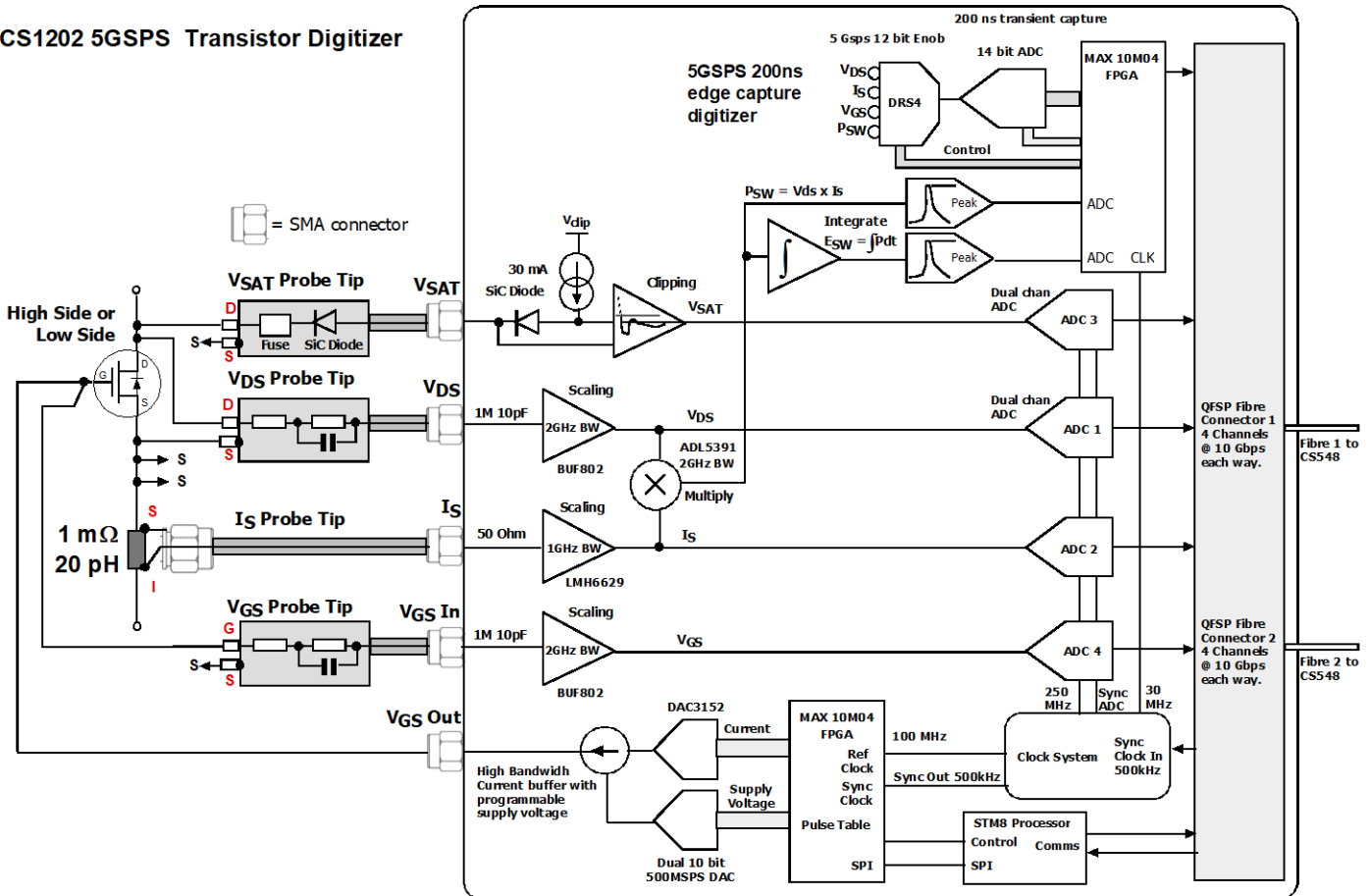

The CS1202 prototype uses 1 GHz BW op-amps driving a 1 GHz BW HW multiplier and integrator to measure switching edge power and energy. The CS1501 is compensated to have 1 GHz BW.

Using a VSAT function and IS we measured the conduction power and energy using the PC application. VSAT has mV resolution.

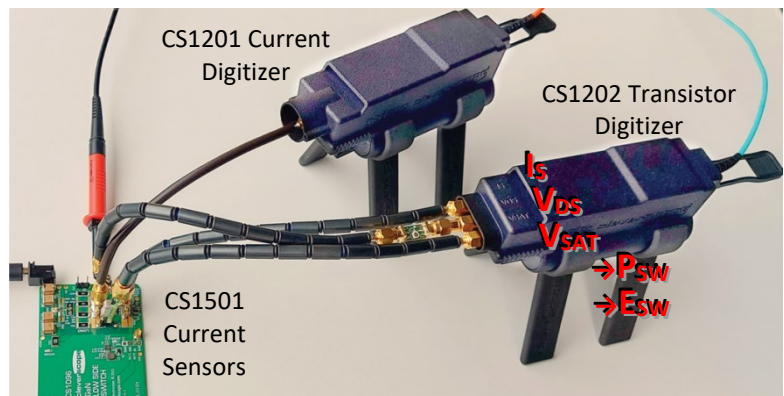

Using the prototypes we made these measurements with a 100ns long pulse:

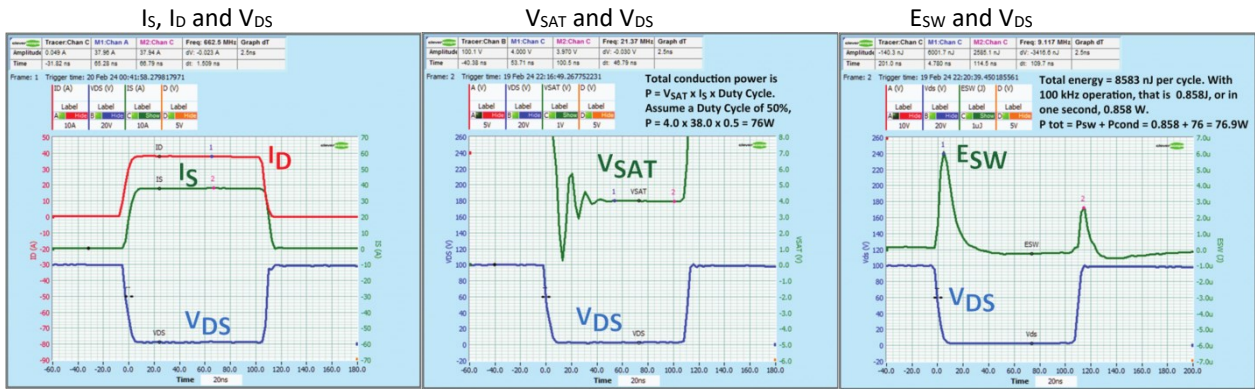

In further work this year, we will implement *step 2*, and add:

- V<sub>GS</sub> measurement.** This is very similar to V<sub>DS</sub> measurement, but with a different probe tip.
- Switch transient capture.** Why capture the whole signal with large sections of slow moving signal at 5 GSPS? This only increases cost and power consumption. Instead, we have decided to capture only the switching edge transient at 5 GSPS, and send this signal, along with slower rate 250 MSPS slow moving signals to the CS548 FPGA. We are using a DRS4 analog transient capture chip to capture a 200ns time window located on the switch edge transient. The transient capture allows you to see the effects of any resonances or non linearity's in the gate drive, transistor turn on, and power flow loop. With the digitizer, we would expect to get 50 samples up a 10ns rise time, and 15 samples up a 3ns rise time - enough to see any non-linearity. We will combine the capture with our up converted 250 MSPS captured waveform to present the full waveform with 200ps resolution, and nearly 1 GHz BW. Amplitude resolution is 12 bit ENOB.

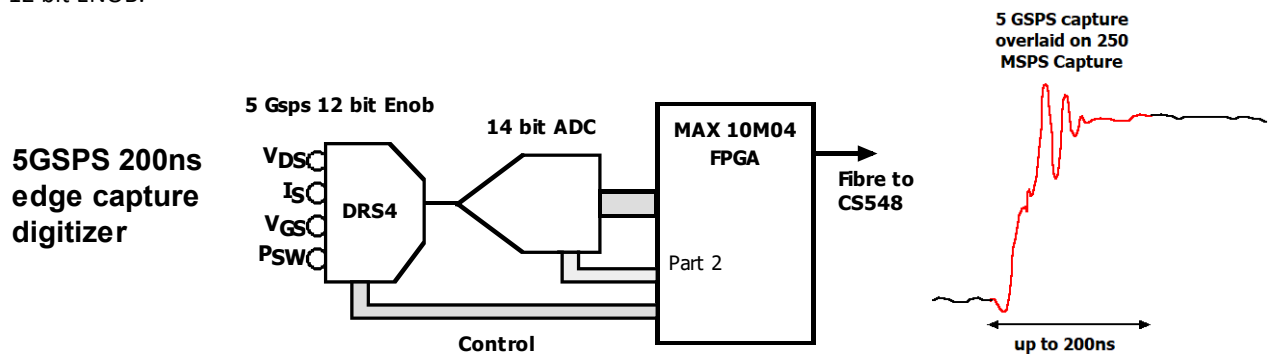

The DRS4 stores the signal into a capacitor capture array which is read out using a 14 bit low noise ADC and sent to the FPGA. The resulting signal has 200ps time resolution, and 12 bit ENOB, with low noise.

The CS1202 transmits 4 x 250 MSPS channels ( V<sub>DS</sub>, I<sub>S</sub>, V<sub>GS</sub>, V<sub>SAT</sub> ) and 4 x 5GSPS channels ( V<sub>DS</sub>, I<sub>S</sub>, V<sub>GS</sub> and P<sub>SW</sub> ) to the PC application around the transient, and just the 4 x 250 MSPS channels the rest of the time. In addition the peak values of P<sub>SW</sub> and E<sub>SW</sub> are transmitted for every edge. These will be used by the PC application to calculate the switching loss, conduction loss and R<sub>DS ON</sub>. Using the CS548, and 50 Msample for each channel buffer, a total duration of 125 msecs can be analysed for E<sub>SW</sub> and E<sub>cond</sub> loss and R<sub>DS ON</sub> over several motor cycles.

- V<sub>GS</sub> Out**

The VGS Out function will be used to programmatically send a current waveform, limited to a programmable voltage ceiling to the gate drive. This will allow closed loop testing of the transistor, to maximize efficiency, while minimizing overshoot, and electromagnetic noise. This will be *step 3*, and achieved with a plug-in daughter board to the CS1202. The CS1202 will initially be supplied without this daughter board, and it can be retrofitted.

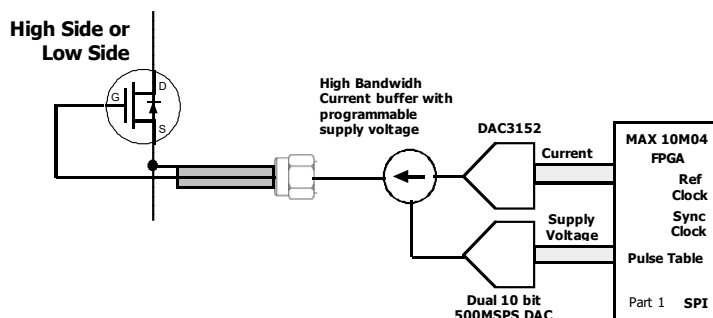

- **CS1203 VSAT digitizer**

In addition to the CS1133 VSAT Probe (see below) the CS1203 supplies a standalone fiber isolated VSAT function for use in Medium Voltage applications up to 10kV switching. This work will be done Q2 2025 based on the existing digitizer.

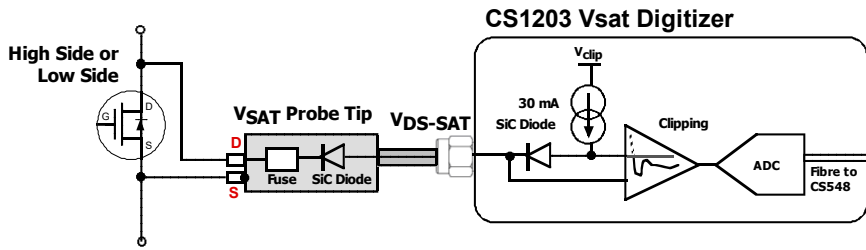

## Other Probes and Modules

### CS1133 VSAT Probe

The CS1133 measures the saturation voltage across a switching transistor with mV resolution. It is direct connected to a CS548 channel, which provides the isolation for high side use.

A power and control isolator provides power and control for high side use. Connections are below:

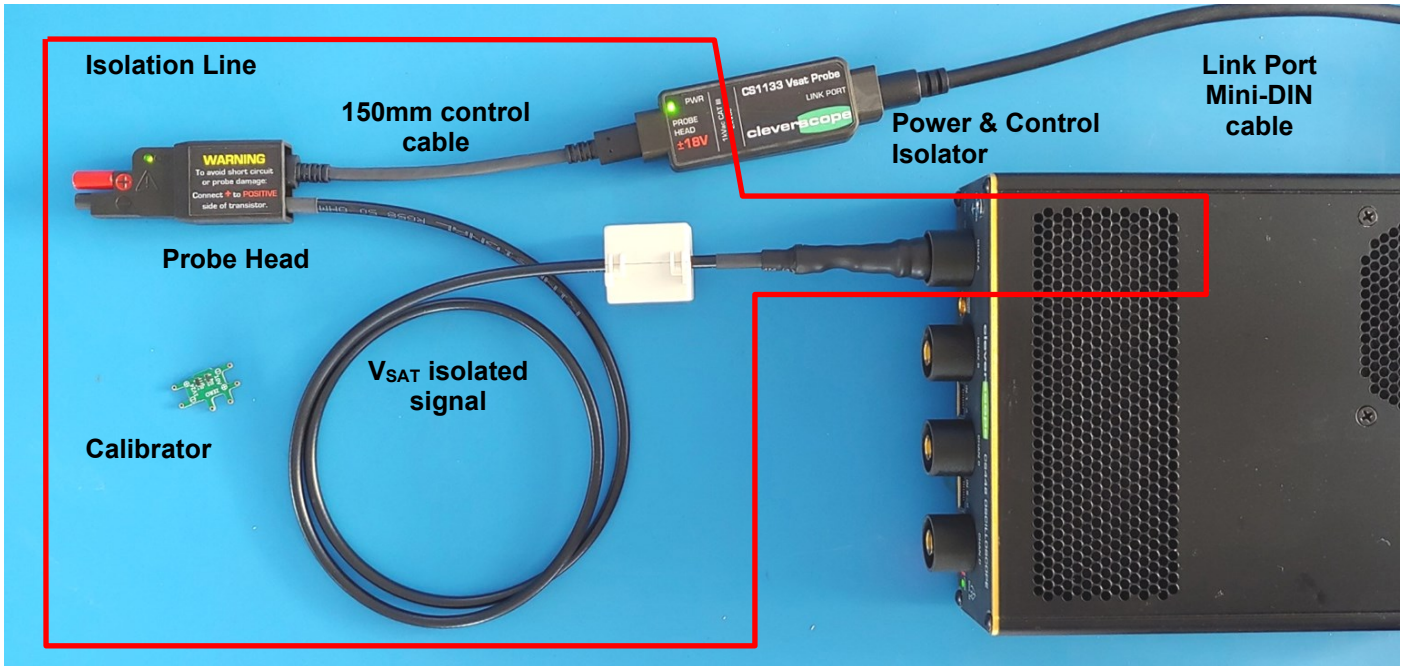

- All items within the isolation line (Channel A, Probe Head, Coax cable and output of Isolator) have a common reference which is the Transistor Source (or Emitter).
- The Probe Head connects directly to the transistor.
- The rated working voltage is 2kV.
- The CS1133 offers three clip levels: 15V, 1.5V and 150mV
- Gain accuracy is  $\leq \pm 1\%$

### CS1124 Probe Hub

The CS1124 allows up to four CS1133's to be used with a CS548, one per channel.



### CS1070 1A 50 MHz 34Vp-p power amplifier

The CS1070 1A power amplifier is useful for PSRR, Impedance and Gain/Phase measurements.

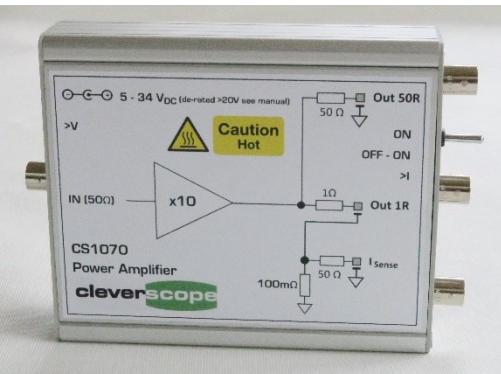

It has 50 MHz BW, and can swing  $\pm 17V$ , and can be offset up to a maximum of 32V. The 50R output is useful for driving impedance matched coaxial cables, while the 1R output can drive low impedance loads such as power and ground planes and power supplies. If battery driven it can be isolated using the CS548 isolated signal generator.

# Software Application

The CS548 software application has many resources to make the most of measurements made. A multi window approach is used with a separate display for each major capability. Copy/paste of window contents are supported. The main displays are:

## Display

## Discussion

The Cscope Control panel controls the application. Key functions are:

- Starting a capture using Single, Auto, Triggered or Streaming capture (continuous for days).
- Defining the trigger channel, level, use of dual trigger and dual trigger definition (see yellow help window - zoom PDF). A digital pattern can gate the capture, or be used as a trigger.
- Control Averaging or Protocol decode. The Protocol Setup window sets up the decode parameters.
- Control and view multi frame and sequence capture (up to 2000 triggered frames).
- Define the display method – sampled, peak captured, repetitive, or averaged in the CS548.
- Includes controls for panning, zooming, annotating, visual trigger setting, auto save options (open/save on trigger, time etc), and digital inputs display.

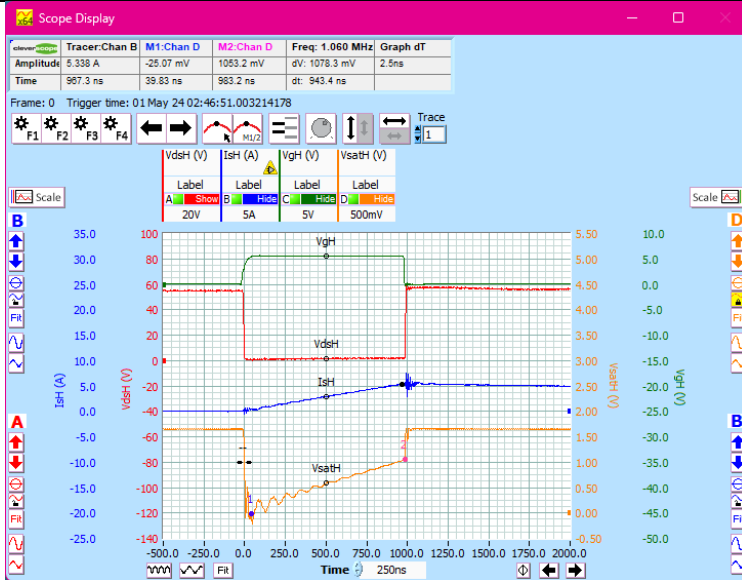

The Scope display sets the amplitude and time values which will be captured by the scope. Scaling is supported. Here the Pulse Builder set the 1us gate pulse, and controlled a boost converter as well.

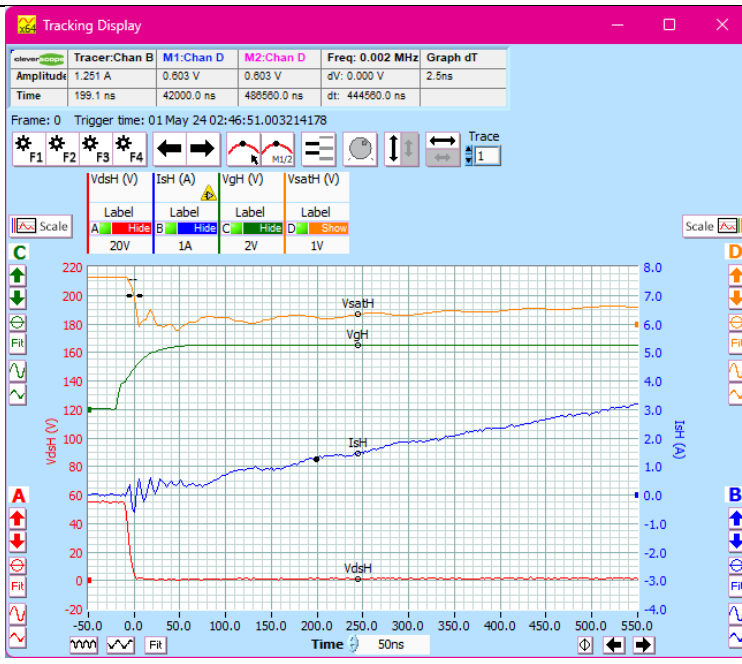

This is the Tracking display. It can track the tracer position in the Scope display. All displays have a similar set of controls. Keyboard short cuts are shown in *Help/About Cleverscope*.

- Controls are:
- Move channel up/down and zoom in/out and reset zero voltage position to centre of display.
  - Move channel left/right and zoom in/out in time. Set the trigger position to the centre of the time axis. Set Time/div.
  - Fit the channel to the display.
  - F1-F4 record, and display for 4 x Display setups.
  - The channel control sets the name of the channel, display the name as a label on a graph, turn on persistence and record a reference, and set Volts/Div.
  - go forward and backward in the history.
  - controls the Marker appearance.
  - The information area above the graph displays the tracer and marker amplitude and time, and deltas.

## Display

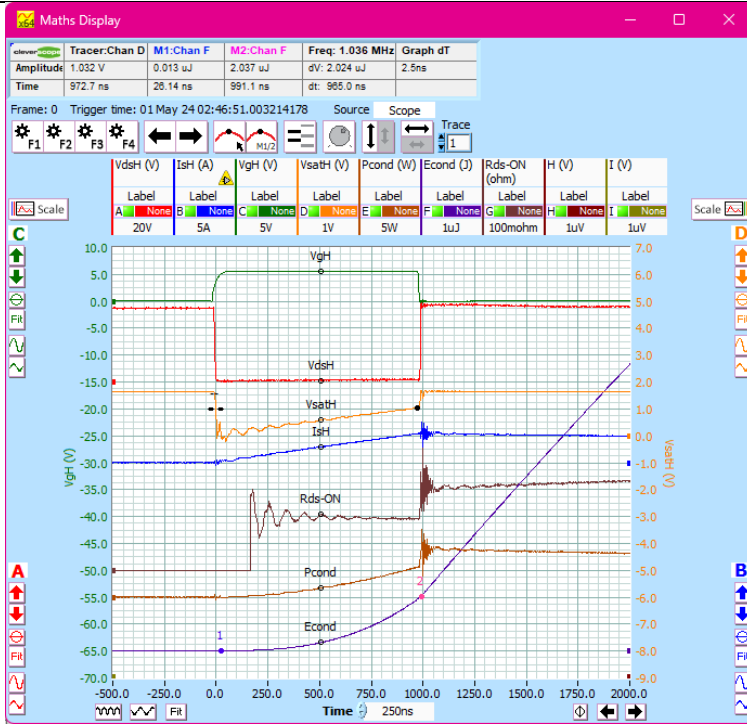

## Discussion

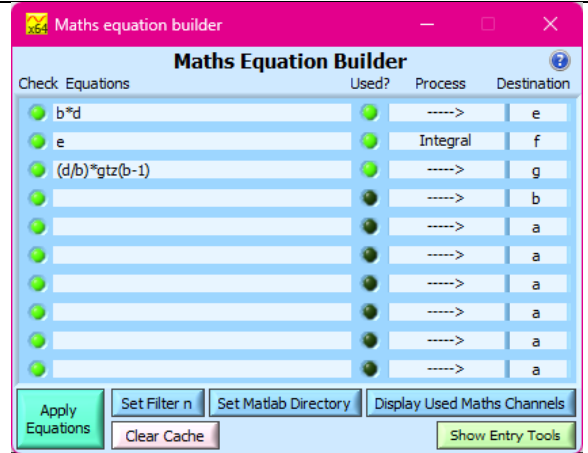

The Maths display runs the Maths Equations and displays the results. Use the Maths Equation builder to enter symbolic maths equations. Referring to above:

- $b*d \rightarrow e$  sends  $IsH \times Vsath$  to  $Pcond$ .
- $e$  integral  $f$  integrates  $Pcond$  and sends to  $Econd$ .
- $(d/b)*gtz(b-1)$  sends  $Vsath/IsH$  to  $Rds-On$ , but only if  $IsH$  is greater than  $1A$

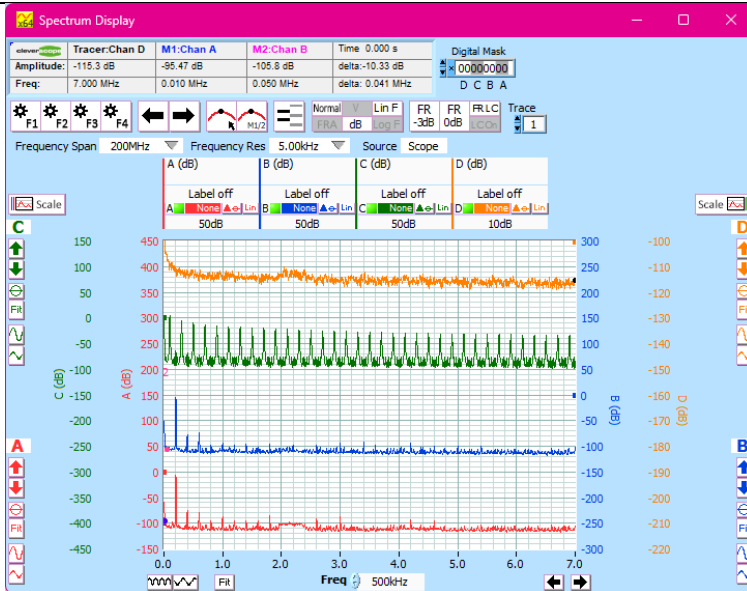

The Spectrum display calculates the Spectrum for the signal in Source (Scope, Tracker, Maths), and displays it. There is full control of Span and Resolution. Graph options are linear, log, Volts or dB.

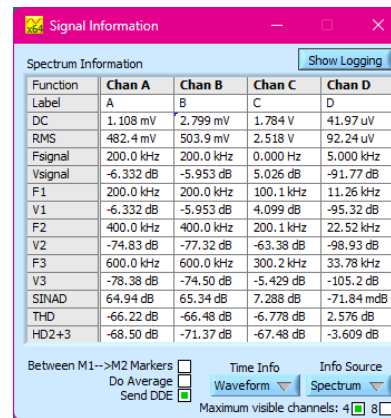

If the Signal Information source is set to Spectrum, common parameters can be displayed. Here Chan A, B were sine, Chan C square, and Chan D open. Note the below -100 dBV noise floor.

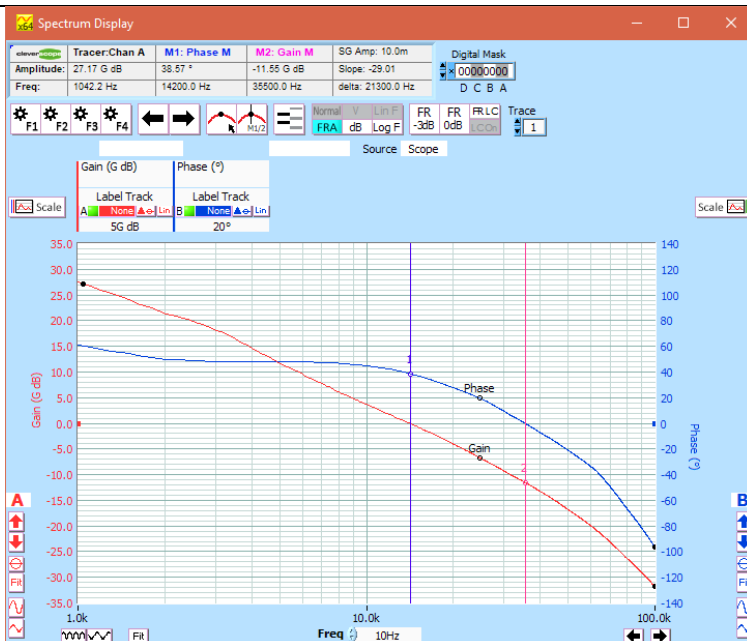

The Spectrum Display is also used for FRA. Here it is displaying an operating Power Supply Unit's Gain/Phase. The Gain and Phase margins are

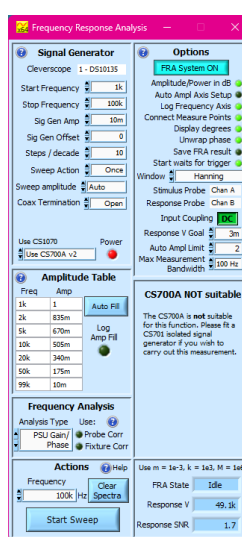

displayed using the FR 0dB button.

The FRA control sets the sig gen frequency range and amplitude, including automatic or table-driven amplitude.

The FRA functions available are listed here:

- ✓ RMS Amplitude
- Power
- Power Density
- Gain/Phase
- Impedance
- Capacitance
- Inductance
- Shunt Impedance
- Calibrate Probes
- Calibrate CS 1070 1R
- Calibrate Fixture
- PSU Gain/Phase
- PSU PSRR
- PSU Output Impedance
- PSU Input Impedance

# System Testing Concept

The CS548 system can be used for general purpose lab testing, end of line module and system testing, and system testing in the field. Module testing may require access to internal circuit nodes, while system testing probably makes use of a connectorized approach. Multiple linked CS548's provide sufficient measurement channels for larger systems. Where helpful, standard current clamp probes or Rogowski current sensors can be used. These application capabilities will be especially useful:

- The Maths Equation builder can derive power, energy,  $R_{DS\ On}$ , Inductance based on over shoot.
- The Spectrum analyser and Information display can display harmonics, EMC limits, Frequency and THD and log these results.
- The Signal information display can display derived values on the Maths Display such as  $R_{DS\ On}$ , Power and Energy between markers, and Frequency, Pulse Width, Duty Cycle, RMS, Peak-Peak, DC, and log these values to disk.
- The 3 Phase power analyser can display V/A/Hz, active and reactive power, efficiency, power factor, voltage and current harmonics, THD, transients, EMC and do logging of results. Both high bandwidth (200 MHz) using the CS548 main channels and low bandwidth (100 kHz) using the measurement pods is supported. \*
- The Pulse Builder can be used to produce Double or Triple Pulse trains, arbitrary pulse trains, PWM for circuit or gate drive stimulation.

## Lab and Development testing

Lab testing is based on one-off development testing. This general purpose use can be illustrated with half bridge design work – including Double Pulse Testing (DPT), Gate Drive verification, switch and conduction loss measurements, parasitic and overshoot:

Using 1 x CS548 and CS1201

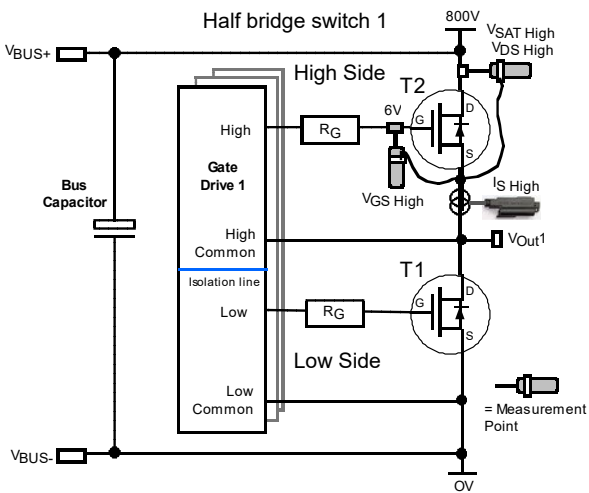

Using 2 x CS548, 2 x CS1201 and a CS1302

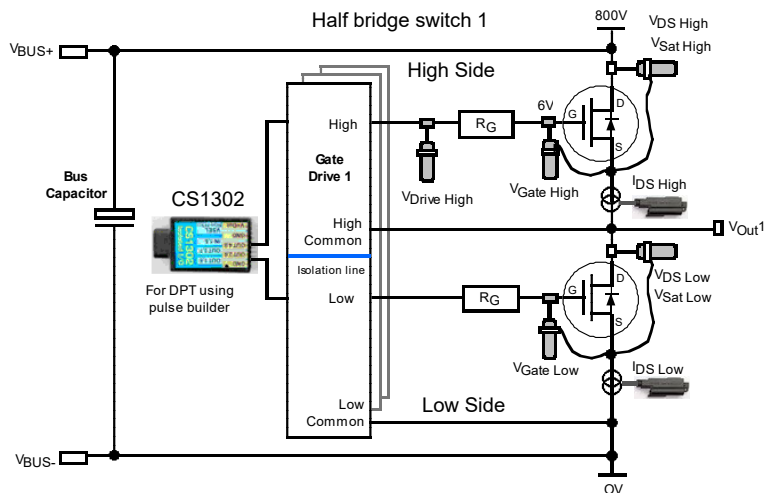

The CS548 system and application offers ample resources for development testing.

## Module test of a three-phase system

A module tester can verify efficiency, EMC, temperature and operation at full and no load on a three-phase system using internal connections. This can be done at high frequency (for EMC, motor current spectra, voltage overshoots and spectra) using the standard channels, or at low frequency using the CS1304 and CS1305 current and voltage pods. The 3-phase system uses 3 half bridges.

Using 2 x CS548, 4 x CS1201+ CS1306 (high frequency test) or 1 x CS548 + 4 x CS1304 + 4 x CS1305 (low frequency test):

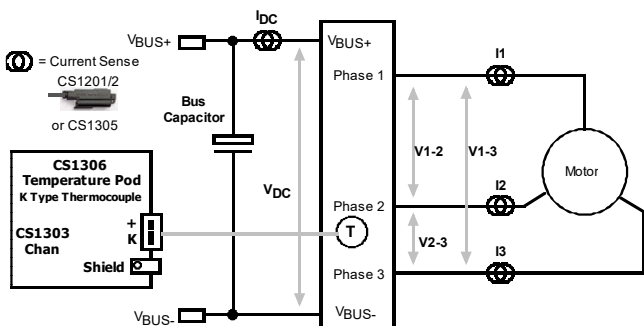

A CS1503 board can be used for wired measurement of the 3-phase connection:

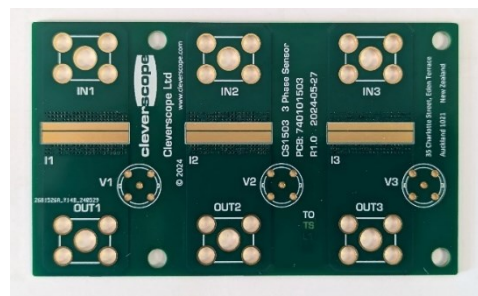

# Common EV or PV module testing

An end of line tester can verify efficiency, EMC, temperature and operation at full and no load on a 3-phase system using internal or external connections. We sketch the connections for some common EV oriented systems. We give the minimum number of channels needed to do a system test. Extra channels may be needed for gate drive and  $V_{DS}$ ,  $V_{SAT}$ ,  $I_S$  measurement.

## Car Charging Station – internal connection tests and complete end of line test

A charging station for direct HV DC charging includes a 3-phase Power Factor Controller (PFC) and an isolated DC-DC converter. These maybe paralleled for higher current. The charging station communicates with the car to set the voltage and current being charged at. This is handled by the controller, which is shown much simplified below.

High frequency tests which verify device level losses, gate drive inter phase timing, resonances and overshoots and inductance estimation can all be done. Using a more system wide approach the power analyzer window can be used to measure 3-phase current, voltage, power and power efficiency, harmonic levels, power factor control, and EMC (to 200 MHz). By using the FRA system, it is possible to measure the controller Gain/Phase and establish stability (correct Gain and Phase margins). The CS1070 power amplifier can help with this if larger signal swings are needed. The CS1301 can be used to display gate drive digital signals to check for driver delay, and pulse integrity (no too short or too long pulse).

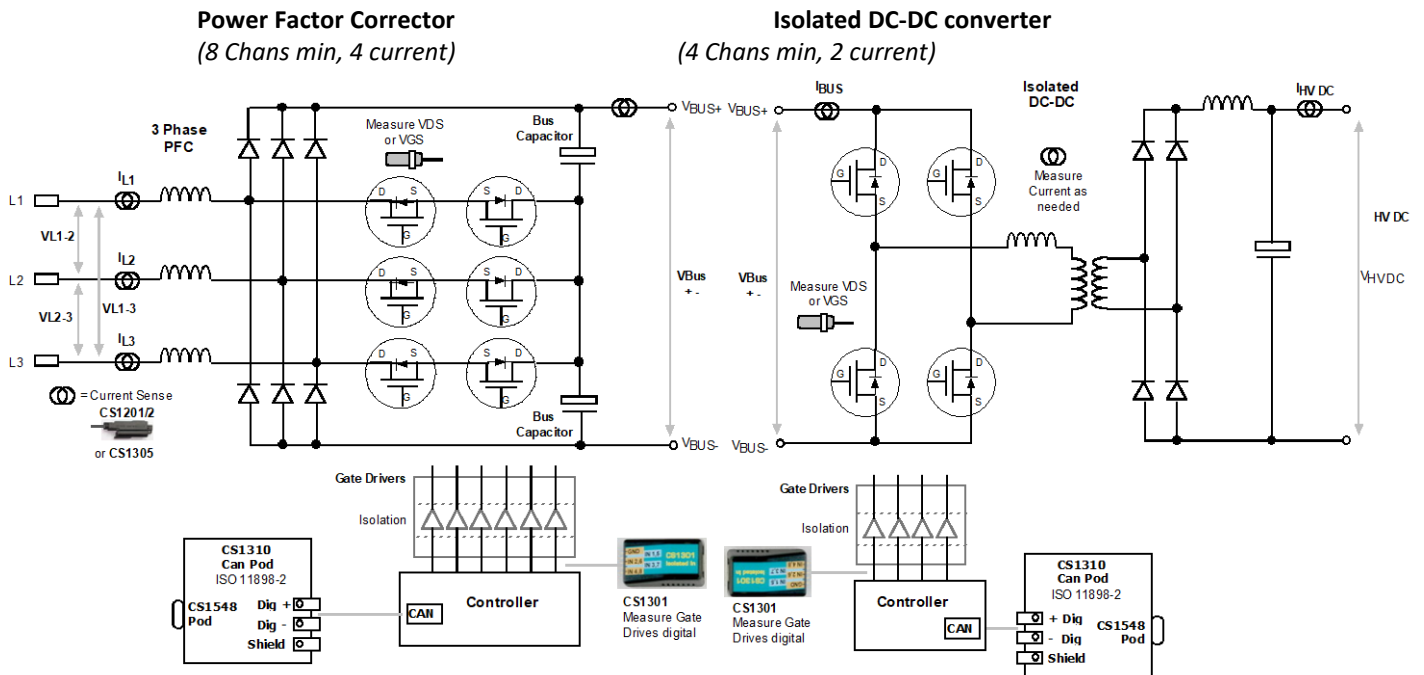

Using 8 Chans, 4 current minimum.

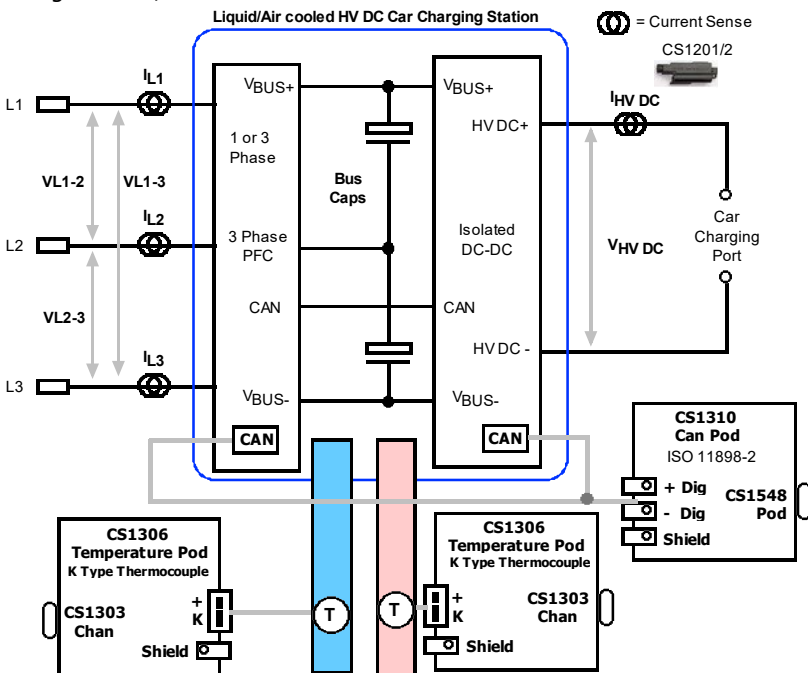

An end of line tester for the full charging station uses external connections and the 3-phase power display to verify current, voltage, power, efficiency, power factor, harmonics, EMC with a wide 200 MHz bandwidth. The CS1306 pods are used to verify the operating temperature margin, and the CS1310 CAN Pod will offer the capability to log CAN messages, or inject CAN commands while carrying out high rate (up to 3 MS/sec) long term streaming from power up to shut down.

### 3-phase variable speed drive

3-phase variable speed drives are used throughout industry to power and control 3-phase induction motors. They can also be used in cars. *Using 12 Chans min, with 6 current.* The CS1202 will reduce this to 6 Chans min (V+I).

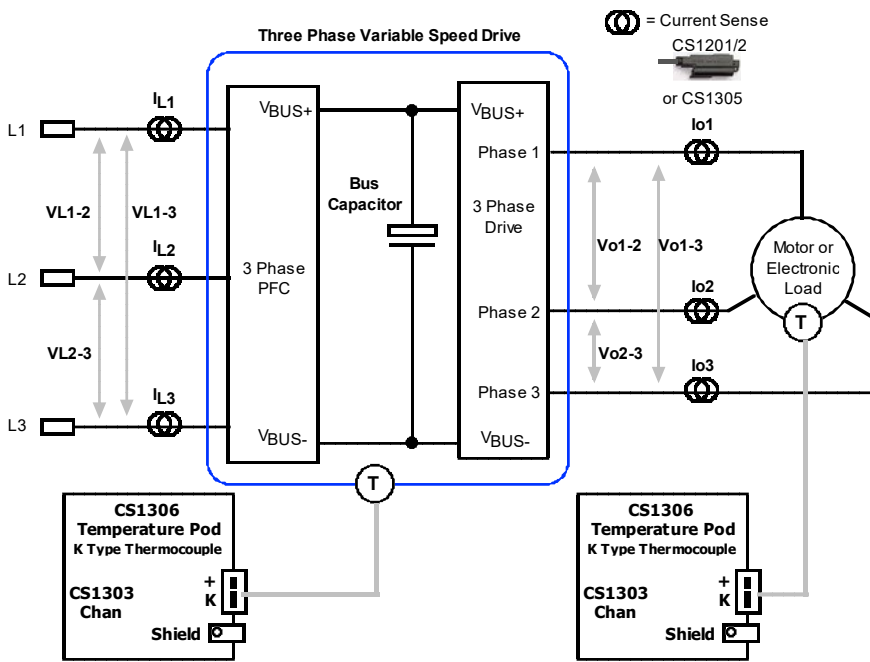

The 3-phase variable speed drive also uses a 3-phase PFC followed by three half bridges. It uses the motor inductance to smooth the current to be sinusoidal. Non sinusoidal components, or harmonics lead to losses in the motor. High dV/dt can stress the motor wire insulation. High dV/dt also produces RF emissions if the motor cable is long or not screened, and the screen connections have not been properly done.

The CS548 isolated system can verify dV/dt, earth leakage current, EMC compliance, current SINAD (Harmonics + distortion – all of which contribute to motor loss). Using the CS1200 and CS1201 fiber connected probes, measurements can be done at both the motor, and the drive input or output, up to 50m away. In this way cable losses can be measured, and the true efficiency measured.

Using the power analysis display, standard power analysis values can be measured. The start, ramp up, ramp down and close down behavior of the whole system can be logged with high rate (3 MSPS) over many hours, including temperature logging. This will expose resonances in the drive system, speed dependent imbalances, and drive performance in response to changing mechanical load.

### Single or 3-phase On Board Charger (OBC)

The vehicle OBC is used to provide at home car charging. It is located in the car, and may communicate with a Home Plug Green PHY connection to optimize charging. The OBC may be rated between 1.4 kW and 7.4kW depending on the mains connection available (worst case is 110V, 13A) and up to 22 kW using a 3-phase connection. Higher power OBC's may be liquid cooled.

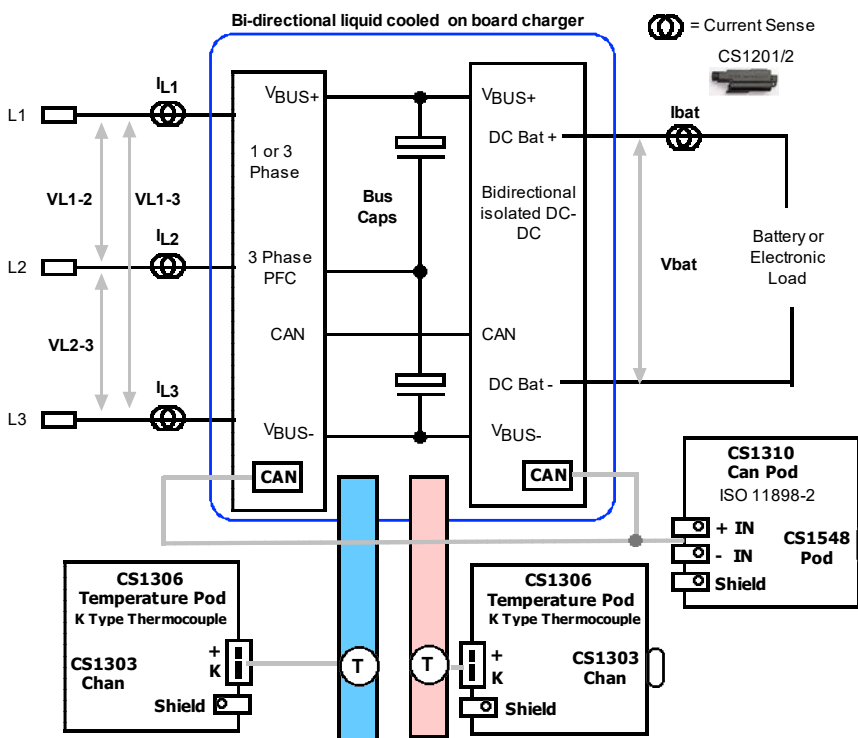

*Using 8 Chans min, with 4 current.*

The OBC maybe single direction only (grid to car) or bi-directional (V2G, V2H or V2L). V2G (Vehicle to Grid) allows export of energy to grid connection (phase and voltage coherent). V2H (Vehicle to Home) can power a home, with a transfer switch to isolate the grid. V2L (Vehicle to Load) can be used to power appliances or other EVs. In the future the Home Plug smart grid connection may be used to collectively supply power to the grid when needed by the grid operator.

In addition to the capabilities discussed in earlier sections, the CS548 system can be used in the V2G configuration to check for phase or voltage imbalance between the OBC and the grid connection, and in the bidirectional applications for the 3-phase current, voltage and reverse power efficiency, harmonics, THD, and efficiency, along with EMC compliance achieved with the >100 dB dynamic range in the spectral domain.

## The competition

To date all the competitors are making a probe that can plug into an existing oscilloscope. The thinking here is that the user already owns the scope, so they just buy the probe, and plug it in. Here are some probes, choosing the model closest to our spec:

Manufacturer	Model	Noise (rms), $\pm 1V$ range	Approx Price (USD)	Must plug into manufacturers brand scope?
Tektronix	TIVH02	1.4 mV	16,400	Yes
LeCroy	DL03-ISO	4.5 mV	15,490	Yes
PMK	Firefly	1.5 mV	17,525	No
MicSig	MOIP03P	3.0 mV	9,800	No
Cleverscope	CS548	0.3 mV	10,800 4 channels	NA
Cleverscope	CS1200 V	0.3 mV	2,980	Yes
Cleverscope	CS1201 I	20 mA	2,980	Yes

All of these probes offer better bandwidth than the CS548 does. However, the CS1202 will offer similar bandwidth on the transients, with better noise, offset and linearity.

These probes do have 5-15 x worse noise, which limits their dynamic range when applied to  $V_{DS}$ ,  $V_{SAT}$  and  $I_S$ . Their DC offset and linearity is worse than the CS548 system, by quite a lot in some cases. They will not perform as well in the frequency domain.

Here is an example of what a probe looks like (Lecroy DL03-ISO):

All of these probes have a:

1. Amplifier and Modulator Module – adds noise, offset and non-linearity
2. Fibre link which conveys analog signals
3. Demodulator module – adds noise, offset and non-linearity
4. Scope interface box.



## Price comparison with selected competitors

Manufacturer	Model	Price (USD)	4 Chan Total Cost (USD)	8 Chan Total Cost (USD)	12 Chans Total Cost (USD)	4/8 Chan 200 MHz scope lowest cost (USD)
Tektronix	TIVH02	16,400	65,600 + scope	131,200 +scope <sup>2</sup>	196,800 + scope <sup>3</sup>	18,800/33,400
LeCroy	DL03-ISO	15,490	61,960 + scope	123,920 +scope <sup>2</sup>	185,880 +scope <sup>3</sup>	14,445 / 24,850
PMK	Firefly	17,525	70,100 + scope	140,200 +scope <sup>2</sup>	210,300 +scope <sup>3</sup>	769/23,690 Rigol/R&S
MicSig	MOIP03P	9,800	39,200 + scope	78,400 +scope <sup>2</sup>	117,600 +scope <sup>3</sup>	769/23,690 Rigol/R&S
Cleverscope	CS548	10,800 (4 channels)	10,800 +	21,600 +	32,400 +	
Cleverscope	CS1201 <sup>1</sup>	2,980	2x = 5960	4x = 11,920	6x = 17,880	

- Note:
1. None of the other manufacturers offer an isolated high CMRR current sensor (yet).
  2. An 8 channel oscilloscope is required.
  3. A 12 channel oscilloscope is required

## Conclusion

The CS548 system is well suited to power electronics measurements, general lab work, and end of line module and system testing. Cleverscope provides a DLL that can be used with Labview, Python, Matlab and Visual Studio etc to automate the testing process. The CS1202 (when available) will provide a good solution for GaN testing. The CS548 system is competitive with all other systems.

Distribution in the UK & Ireland



**Characterisation,  
Measurement &  
Analysis**

**Lambda Photometrics Limited**  
 Lambda House Batford Mill  
 Harpenden Herts AL5 5BZ  
 United Kingdom  
 E: [info@lambdaphoto.co.uk](mailto:info@lambdaphoto.co.uk)  
 W: [www.lambdaphoto.co.uk](http://www.lambdaphoto.co.uk)  
 T: +44 (0)1582 764334  
 F: +44 (0)1582 712084