

Picoprobe®

BY GGB INDUSTRIES INC.

Model 75

High Performance Microwave Probes



Model 75 Picoprobe® with bias T

The Model 75 Picoprobe® sets new standards in microwave probing performance. Benefiting from coaxial techniques, which have inherent low loss and low dispersion characteristics, the Model 75 Picoprobe®, with or without the bias T option, achieves an insertion loss of less than 1.0 db (typical) and a return loss of greater than 15 db (max.) over its frequency range.

With its individually spring loaded, Beryllium-Copper tips, the Model 75 Picoprobe® provides reliable contacts, even when probing non-planar structures. This reliable low resistance contact is one of the keys to providing highly repeatable measurements (-50 db) at V band frequencies. The Model 75 Picoprobe® also provides direct viewing of the probe tips for accurate positioning.

Any pitch (tip spacing) from 50 microns and up may be specified. The probe can be configured with Ground-Signal-Ground (G,S,G), Ground-Signal (G,S), or Signal-Ground (S,G) tip footprints. We recommend smaller pitches with a G,S,G footprint for best performance. Most customers are using GSG probes with a pitch of 100 to 250 microns.

Features

- Durable
- 50 GHz to 75 GHz
- Insertion loss 1.25 db max.
- Return loss 15 db max.
- Individually spring loaded contacts
- Measurement repeatability -50 db
- Bias T option available
- Patented coaxial design

Distribution in the UK & Ireland



Characterisation,
Measurement &
Analysis

Lambda Photometrics Limited
Lambda House Balford Mill
Harpenden Herts AL5 5BZ
United Kingdom

E: info@lambdaphoto.co.uk

W: www.lambdaphoto.co.uk

T: +44 (0)1582 764334

F: +44 (0)1582 712084

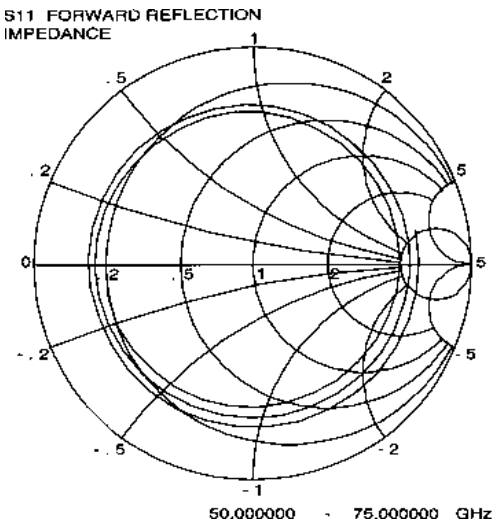
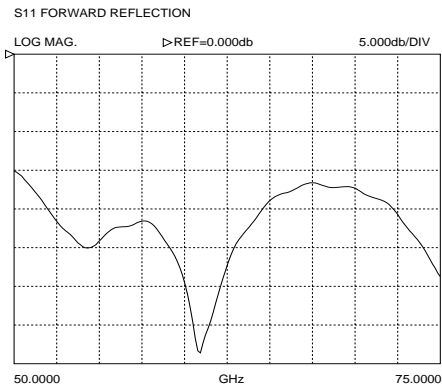

Forward reflection into an open ended 50 ps coplanar line after a one port SOLT calibration was performed using our CS-5 calibration substrate. The smooth inwardly spiraling line shows the increasing loss of the 50 ps coplanar line with frequency, coupled with a smoothly changing phase.

The CS-5 will also perform excellent LRL and LRM V-band calibrations. More data available on request.

Typical uncalibrated performance of a Model 75-GSG-100-BT while touching a 50 ohm load on our CS-5 calibration substrate.

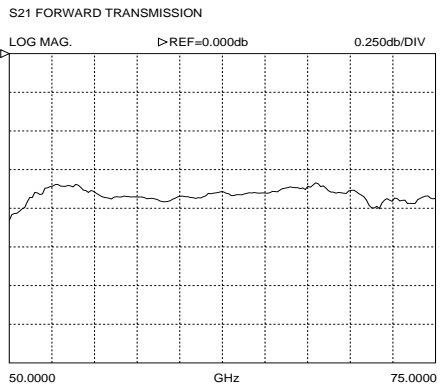

Typical insertion loss of a Model 75-GSG-100-BT

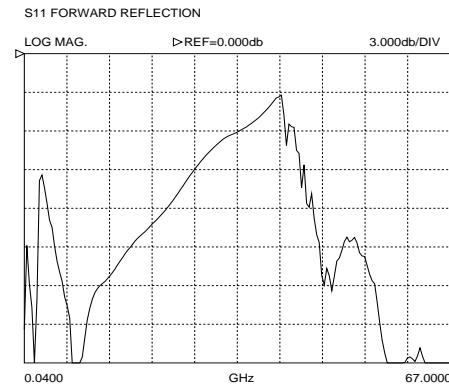

The Model 75 Picoprobe® bias T provides a direct low resistance DC path for supplying up to 1.5 A to a device under test. The bias T also has special circuits which add loss at frequencies below the cut off frequency (39.86 GHz) of WR-15 waveguide. This data was taken by launching a, 40 MHz to 67 GHz, signal from the tips of a calibrated Model 67A Picoprobe® into the tips of a Model 75-GSG-150-BT. Without this low frequency loss most active devices will oscillate.

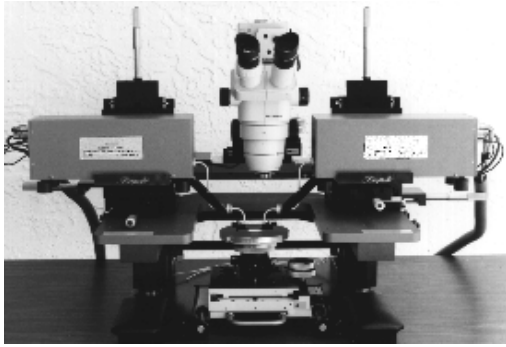

Micropositioners are available to hold Wiltron V band modules so that the module and the probe are micropositioned as a single unit. In this way, total ease of positioning can be achieved with minimum insertion loss.

The probes also have a 3 hole mounting adaptor which will fit standard microwave probe stations. In this case, a longer section of waveguide may be desired to add positioning flexibility.

Covered by US patent # 4,871,964

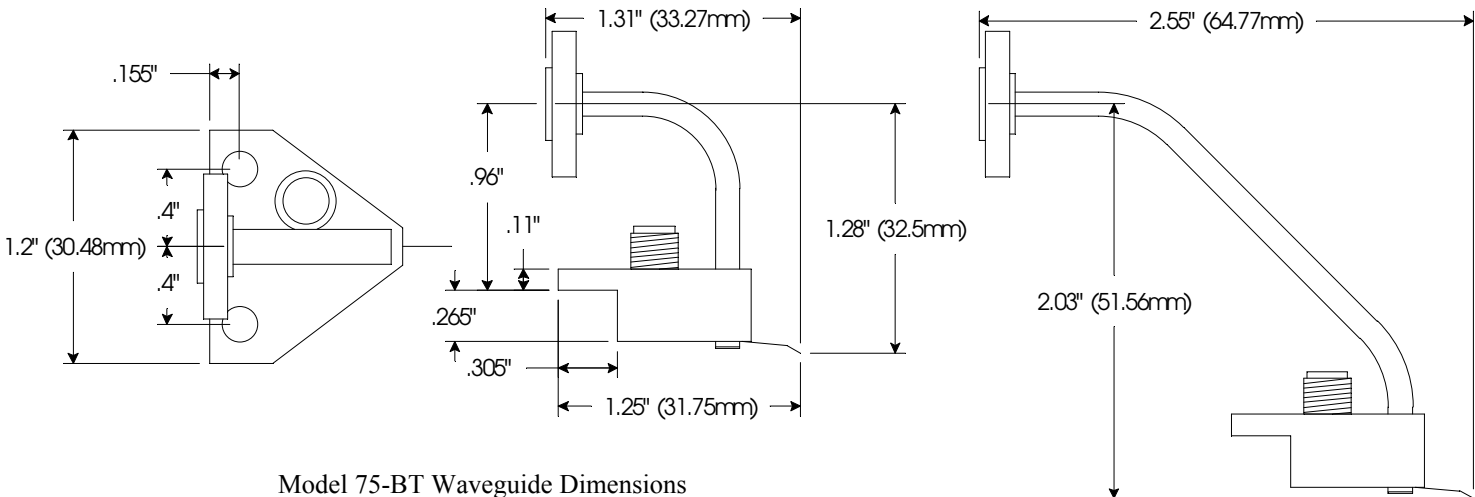

Model 75-BT Waveguide Dimensions

Model 75-BT-M Waveguide Dimensions