

Picoprobe®

BY GGB INDUSTRIES INC.

Model 90

High Performance Microwave Probes



Model 90 Picoprobe with bias T

Features

- **Durable**
- **60 GHz to 90 GHz**
- **Insertion loss 1.5 db max. (60 to 90 GHz)**
- **Return loss 15 db max. (60 to 90 GHz)**
- **Individually spring loaded contacts**
- **Measurement repeatability -50 db**
- **Bias T option available**
- **Patented coaxial design**

The Model 90 Picoprobe sets new standards in microwave probing performance. Benefiting from coaxial techniques, which have inherent low loss and low dispersion characteristics, the Model 90 Picoprobe achieves an insertion loss of less than 1.5 db and a return loss of greater than 15 db over its frequency range. The Model 90 has a WR-12 waveguide input and a K connector DC input.

With its individually spring loaded, Beryllium-Copper tips, the Model 90 Picoprobe provides reliable contacts, even when probing non-planar structures. This reliable low resistance contact is one of the keys to providing highly repeatable measurements. The Model 90 Picoprobe also provides direct viewing of the probe tips for accurate positioning.

Any pitch (tip spacing) from 50 to 450 microns may be specified. The probe can be configured with Ground-Signal-Ground (G,S,G), Ground-Signal (G,S), or Signal-Ground (S,G) tip footprints. We recommend smaller pitches with a G,S,G footprint for best performance.

Covered by US patent # 4,871,964

Distribution in the UK & Ireland



**Characterisation,
Measurement &
Analysis**

Lambda Photometrics Limited
Lambda House Batford Mill
Harpenden Herts AL5 5BZ
United Kingdom

E: info@lambdaphoto.co.uk
W: www.lambdaphoto.co.uk
T: +44 (0)1582 764334
F: +44 (0)1582 712084

S11 FORWARD REFLECTION

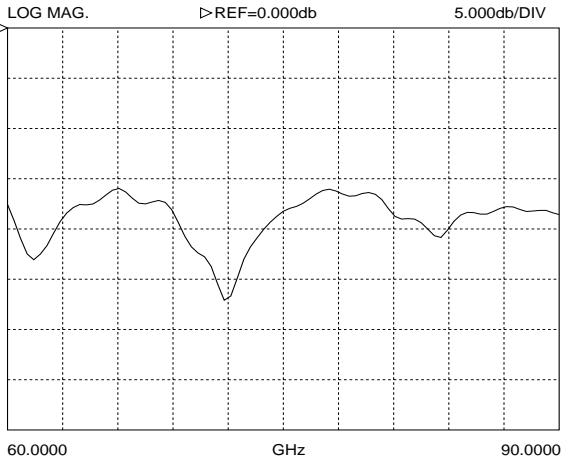

Typical uncalibrated performance of a Model 90-GSG-150-BT while touching a 50 ohm load on our CS-5 calibration substrate.

The CS-5 will also perform excellent LRL and SOLT W-band calibrations. More data available on request.

S21 FORWARD TRANSMISSION

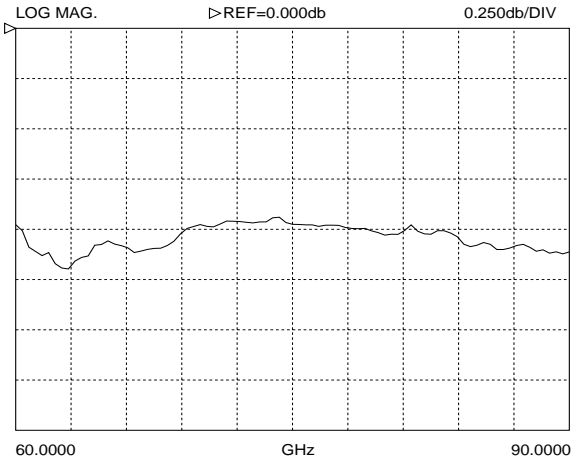

Typical insertion loss of a Model 90-GSG-150-BT

Covered by US patent # 4,871,964

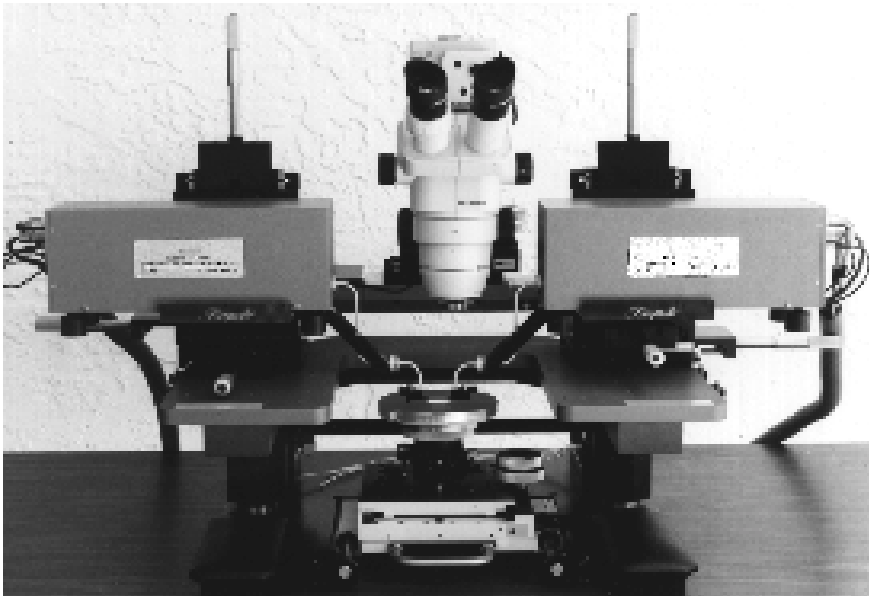

The Model 90 Picoprobe bias T provides a direct low resistance DC path for supplying up to 1.5 A to a device under test. The bias T also has special circuits which add loss at frequencies below the cut off frequency (48.35 GHz) of WR-12 waveguide. Without this low frequency loss most active devices will oscillate.

Micropositioners are available to hold Wiltron W band modules so that the module and the probe are micropositioned as a unit. In this way, total ease of positioning can be achieved with minimum insertion loss.

The probes also have a 3 hole mounting adaptor which will fit standard microwave probe stations. In this case, a longer section of waveguide between the probe and the W band module may be desired to add positioning flexibility.

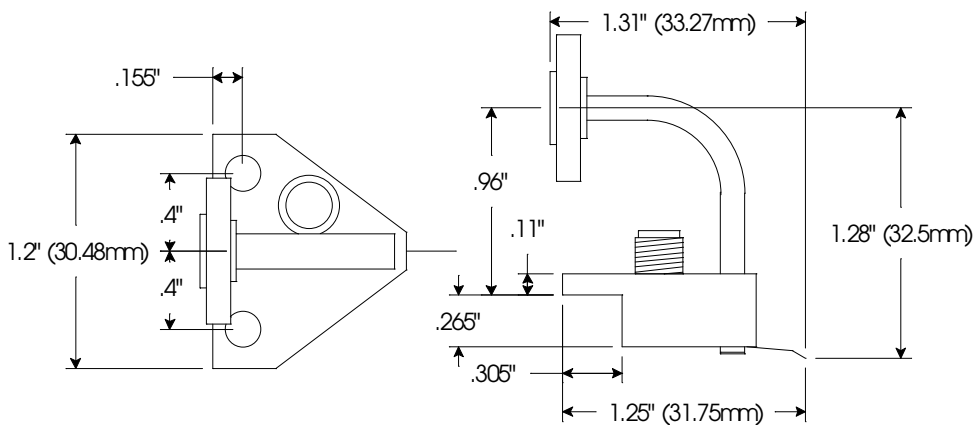

Model 90-BT Waveguide Dimensions

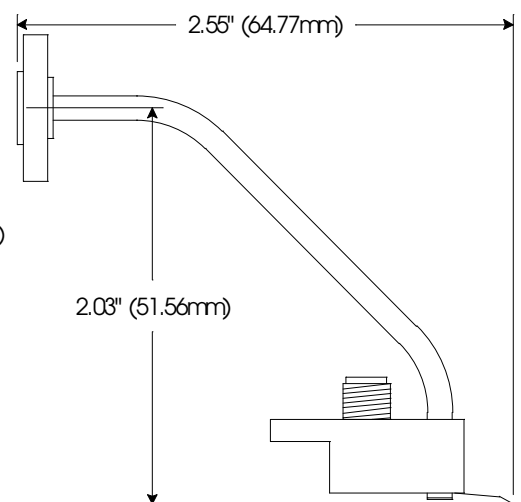

Model 90-BT-M Waveguide Dimensions