

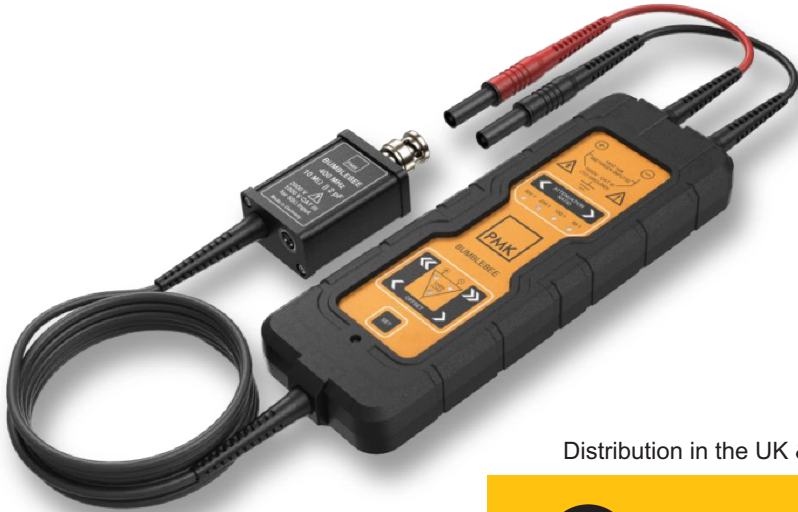

Probing Solutions.
Made in Germany.

EN



Distribution in the UK & Ireland



Lambda

www.lambdaphoto.co.uk

BumbleBee[®] Series

High Voltage Differential Probes
with Universal BNC Interface

up to 500 MHz, up to ± 2000 V
500:1 to 5:1

Hardware Revision B from SN 2000

Datasheet



About BumbleBee® Probe Series

The PMK BumbleBee® high voltage differential probe series offers industry leading performance up to 500MHz bandwidth for today's power device design challenges, especially those using wide bandgap devices, such as SiC and GaN. The $\pm 2000\text{V}$, $\pm 1000\text{V}$, $\pm 400\text{V}$ and $\pm 200\text{V}$ differential and common-mode input voltage ranges makes BumbleBee® probes an ideal choice for designing and evaluating power circuits, such as switching power supplies, motor drives, inverter, IGBT circuits and frequency converters in the different voltage classes. BumbleBee® series probes have four adjustable input attenuation ranges allowing the user to select the voltage range needed to achieve the lowest noise and best possible resolution.

The BumbleBee® series probes have a universal BNC output connector and are compatible with any oscilloscope in the lab with 50Ω input impedance, or $1\text{M}\Omega$ input impedance and a 50Ω feed-through termination.

All BumbleBee® series models require a power supply, which is not included in the scope of delivery, and has to be ordered separately. Review the *Ordering Information* at the end of this document for more details. The interface box is powered by the required PMK power supply. The referring power supplies all have remote control capabilities and therefore a USB interface and optional additional LAN interface. As an alternative for most flexible use, the 1 channel battery pack power supply AP-01 provides >8h of portable and isolated operation but has no software remote control.

BumbleBee® series has the capability to be controlled from either remote control or the controls located on the interface box.

- For remote control PMK offers the software "PMK Probe Control" with graphical user interface, which is shipped with any referring power supply, e.g. PS02 or PS03, and is available for download at: <http://www.pmk.de/en/products/probecontrol>
- In addition, the Python package "PMK-probes" is available as a programming interface for controlling PMK's active probes. Installation instructions, examples and documentation is available at: <https://pmk-probes.readthedocs.io/en/latest/>

Measurement Principle

The high voltage differential probe series BumbleBee® consists of two balanced precision attenuators, which are differentially matched. The attenuators scale the input voltage before passing into the differential amplifier. The output of the differential is fed over a driver stage to the 50Ω input of a measuring device.

Specifications

Read the Instruction Manual before first use and keep it for future reference. A digital copy of the latest Instruction Manual revision can be downloaded at www.pmk.de.

Do not exceed the specifications. Allow the probe to warm up for 20 minutes. This probe comes with 2 years warranty. Each specification is determined at +23°C ambient temperature.

Electrical Specifications

Electrical Specifications¹ that are not marked with (*) as guaranteed are typical.

Model: Article number:	±2000V BumbleBee 880-102-501 (2 m) 880-106-501 (6 m) 880-107-501 (7 m)	±1000V BumbleBee 880-132-501 (2 m) 880-137-501 (7 m)
Attenuation* ($< \pm 1\%$ guaranteed)	500:1, 250:1, 100:1, 50:1	250:1, 125:1, 50:1, 25:1
Bandwidth* (-3 dB) Small Signal (guaranteed)	250:1, 500:1: 400 MHz 50:1, 100:1: 400 MHz	250:1, 125:1: 500 MHz 50:1, 25:1: 400 MHz
Rise time (10 % - 90 %) Small Signal	250:1, 500:1: 0.9 ns 50:1, 100:1: 1.0 ns	250:1, 125:1: 0.8 ns 50:1, 25:1: 0.95 ns

Maximum Rated Input Voltages²

No Measurement Category	2000 Veff. 6000 V transient overvoltage	1000 Veff. 1000 V transient overvoltage
CAT Rating	1000 V CAT III	300 V CAT II
Pollution Degree	2	
Maximum Differential Input Voltage (DC + AC peak)	500:1: ± 2000 V 250:1: ± 1000 V 100:1: ± 400 V 50:1: ± 200 V	250:1: ± 1000 V 125:1: ± 500 V 50:1: ± 200 V 25:1: ± 100 V
Common Mode Voltage	± 2000 V peak (1400 V rms)	± 1000 V peak (700 V rms)
DC Gain Accuracy ³	500:1, 250:1: $\pm 0.35\%$ 100:1, 50:1: $\pm 0.7\%$	250:1, 125:1: $\pm 0.35\%$ 50:1, 25:1: $\pm 0.7\%$
Propagation Delay (± 0.5 ns)	12 ns (2 m), 28 ns (6 m) 32.5 ns (7 m)	12 ns (2 m), 32.5 ns (7 m)
Noise (AC RMS) ⁴	500:1, 250:1: 75 mV 100:1, 50:1: 55 mV	250:1, 125:1: 37 mV 50:1, 25:1: 27 mV

Input Impedance⁵

Each Input to Ground	5 M Ω 5 pF	2.5 M Ω 5 pF
Differential Input Impedance	10 M Ω 2.5 pF	5 M Ω 2.5 pF
Common Mode Rejection Ratio (CMRR)	DC: 80 dB 100 kHz: 70 dB 1 MHz: 70 dB 3.2 MHz: 62 dB 10 MHz: 50 dB 50 MHz: 45 dB 100 MHz: 40 dB 400 MHz: 35 dB	DC: 80 dB 100 kHz: 70 dB 1 MHz: 70 dB 3.2 MHz: 62 dB 10 MHz: 50 dB 50 MHz: 45 dB 100 MHz: 40 dB 400 MHz: 35 dB

More models and foot notes on next page...

Model Article number	± 400 V BumbleBee 880-122-501 (2 m) 880-127-501 (7 m)	± 200 V BumbleBee 880-112-501 (2 m) 880-117-501 (7 m)
Attenuation* ($< \pm 1\%$ guaranteed)	100:1, 50:1, 20:1, 10:1	50:1, 25:1, 10:1, 5:1
Bandwidth* (-3 dB) Small Signal (guaranteed)	100:1, 50:1: 500 MHz 20:1, 10:1: 400 MHz	50:1, 25:1: 500 MHz 10:1, 5:1: 400 MHz
Rise time (10% - 90%) Small Signal	100:1, 50:1: 0.8 ns 20:1, 10:1: 0.95 ns	50:1, 25:1: 0.8 ns 10:1, 5:1: 0.95 ns
Maximum Rated Input Voltages ²		
No Measurement Category	400 Veff. 1000 V transient overvoltage	200 Veff. 1000 V transient overvoltage
CAT Rating	150 V CAT II	150 V CAT II
Pollution Degree	2	
Maximum Differential Input Voltage (DC + AC peak)	100:1: ± 400 V 50:1: ± 200 V 20:1: ± 80 V 10:1: ± 40 V	50:1: ± 200 V 25:1: ± 100 V 10:1: ± 40 V 5:1: ± 20 V
Common Mode Voltage	± 400 V peak (280 V rms)	± 200 V peak (140 V rms)
DC Gain Accuracy ³	100:1, 50:1: ± 0.35 % 20:1, 10:1: ± 0.7 %	50:1, 25:1: ± 0.35 % 10:1, 5:1: ± 0.7 %
Propagation Delay (± 0.5 ns)	12 ns (2 m), 32.5 ns (7 m)	12 ns (2 m), 32.5 ns (7 m)
Noise (AC RMS) ⁴	100:1, 50:1: 14 mV 20:1, 10:1: 11 mV	50:1, 25:1: 7 mV 10:1, 5:1: 5 mV
Input Impedance ⁵		
Each Input to Ground	1.125 MΩ 5 pF	500 kΩ 5 pF
Differential Input Impedance	2.25 MΩ 2.5 pF	1 MΩ 2.5 pF
Common Mode Rejection Ratio (CMRR)	DC: 80 dB 100 kHz: 70 dB 1 MHz: 70 dB 3.2 MHz: 62 dB 10 MHz: 50 dB 50 MHz: 45 dB 100 MHz: 40 dB 400 MHz: 35 dB	DC: 80 dB 100 kHz: 70 dB 1 MHz: 70 dB 3.2 MHz: 62 dB 10 MHz: 50 dB 50 MHz: 45 dB 100 MHz: 40 dB 400 MHz: 35 dB

¹ Determined when using a PS-02 power supply.

² As defined within IEC 61010-031. See definitions in the manual.

³ Input voltage >25%

⁴ Related to the input. Wideband noise DC - 30 MHz.

⁵ Including input leads. Measuring frequency 1 MHz, cable leads in parallel.

Mechanical Specifications

Parameter	Specification
Weight (Probe only)	370 g
Length	Model dependent
Probe Input ¹	4mm safety banana (male)
Output Connector	BNC (male)

Notes:

¹ Different accessories for connectivity are available. Please review the section “Ordering Information”.

Environmental Specifications

Parameter	Specification
Temperature Range	Operating: 0 °C to +50 °C
	Non-Operating: -40 °C to +71 °C
Maximum Relative Humidity	Operating: 80 % relative humidity for temperatures up to +31 °C, decreasing linearly to 40 % at +50 °C
	Non-Operating: 95 % relative humidity for temperatures up to +40 °C
Altitude	Operating: up to 2000 m
	Non-Operating: up to 15000 m

Dimensions

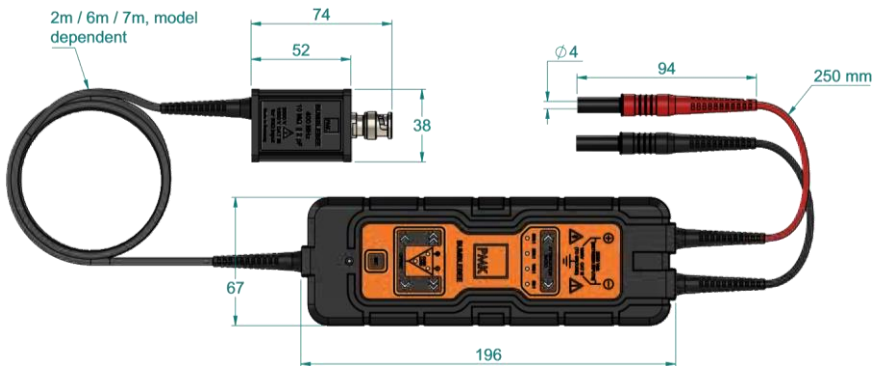

Probe's power supply pin assignment



Probe's power supply pin assignment “cable view”



Observe the probe's power supply pin assignment.

Typical Voltage Derating



Note that the maximum input voltage rating of the probe decreases as the frequency of the applied signal increases.

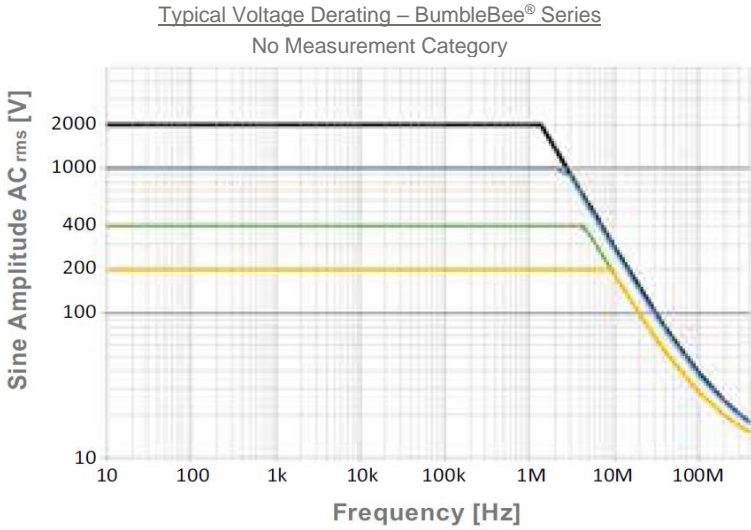

Typical Input Impedance



The input impedance of the probe decreases as the frequency of the applied signal increases.

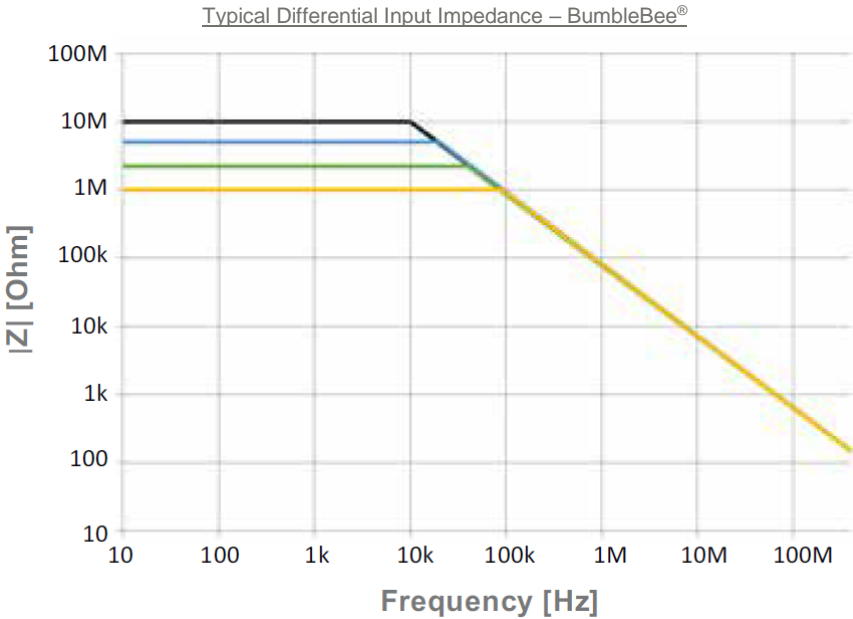

Maximum Input Voltage, Example 2000V Model, 500:1 Range

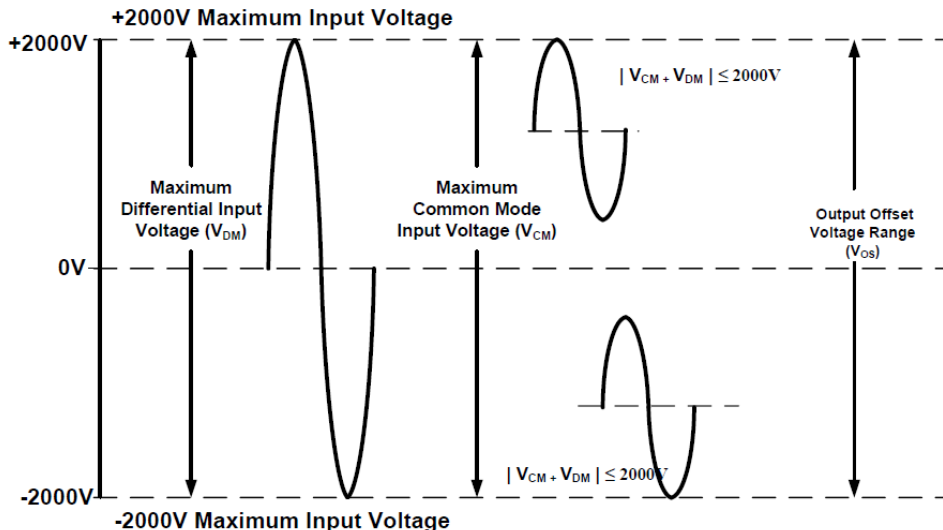

Maximum Input Voltage, Example 200V Model, 5:1 Range

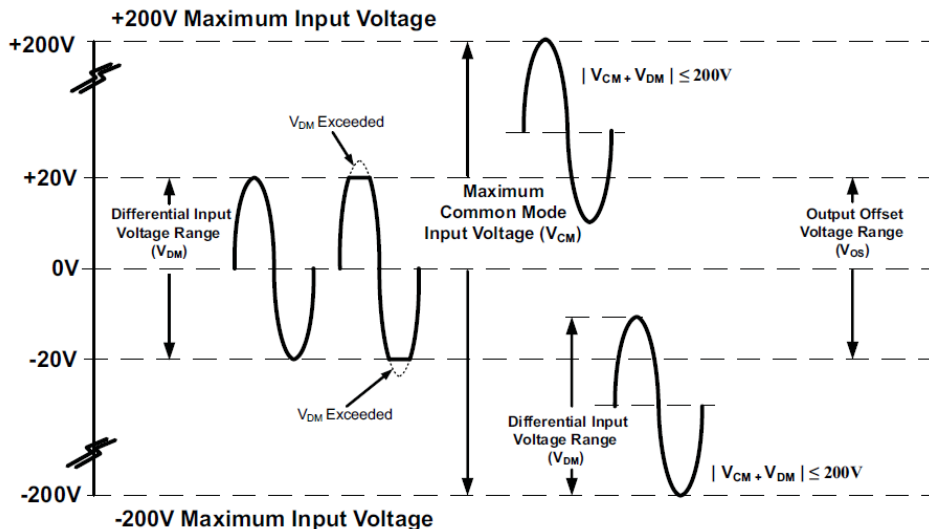

Cleaning

To clean the exterior of the probe, use a soft cloth moistened with either distilled water or isopropyl alcohol. Before use allow the probe to dry completely.

Scope of Delivery

A PMK power supply is required for all models. See chapter “Ordering Information” to review the selection.

Probe BumbleBee® series (different model, different color)

Factory calibration certificate

Instruction manual



n/a

890-520-000

Power Supply Cable (0.5 m), 30VAC / 60V DC
(1.5m cable available as option)

890-880-103

Pair of Probe Tip Adaptors 4mm to 0.8mm (2x black) – spare part



2x 890-808-105

2-Footer



890-880-102

Set of 4 Spring Tips (fine)



890-880-101

Set of 10 Contact Pins 0.64mm



890-880-110

Pair of Spade Terminals, narrow (black / red), 30V AC / 60V DC



890-880-107

Pair of Spade Terminals, wide (black, red), 30V AC / 60V DC



890-880-116

4 mm Coupler f-f (red)



890-880-109

Pair of Magnet Connectors 4 mm (black, red)



890-880-115

Pair of Clamps, Hook (black & red),
1000V CAT II



890-880-114

Pair of Clamps, Jaws (black & red)
1000V CAT III



890-880-113

Pair of Clamps, Rotating Grip Jaw (black & red)
1000V CAT II



890-880-108

Pair of Safety Alligator Clips, big (black & red), 1000V CAT III



890-880-111

Pair of Safety Alligator Clips, small (black & red), 600V CAT III



890-880-106

Pair of Mini Spring Tip Probes 4 mm (black, red), 600V CAT II -spare part



Ordering Information

Step 1: Select the Probe

Each probe has four selectable input dividers included. The power supply must be ordered separately.

880-102-501	BumbleBee® $\pm 2000V$, 2 m
880-106-501	BumbleBee® $\pm 2000V$, 6 m
880-107-501	BumbleBee® $\pm 2000V$, 7 m
880-132-501	BumbleBee® $\pm 1000V$, 2 m
880-137-501	BumbleBee® $\pm 1000V$, 7 m
880-122-501	BumbleBee® $\pm 400V$, 2 m
880-127-501	BumbleBee® $\pm 400V$, 7 m
880-112-501	BumbleBee® $\pm 200V$, 2 m
880-117-501	BumbleBee® $\pm 200V$, 7 m

Step 2: Select Additional Accessories

Note, that any additional accessory degrades the probe's performance. Always observe the lowest Maximum Input Voltage. Do not use any other accessories than recommended by PMK.

891-102-EMC

Noise Suppression Kit, recommended for use in environments with high levels of interference (EMI), (3x ferrites & opening key)



016-397-049

Carrying Case with Foam Inlay (black)



4mm-SMA-M

4mm safety banana socket to SMA plug adapter, for high-frequency voltage measurements, 500V DC + AC pk, 1000V peak pulse



4mm-MMCX-M

4mm safety banana socket to MMCX plug adapter, for high-frequency voltage measurements, 250V DC + AC pk, 500V peak pulse



4mm-BNC-M

4mm safety banana socket to BNC plug adapter, for high-frequency voltage measurements, 750V DC + AC pk, 1500V peak pulse



4mm-WSQ-5.08

4mm safety banana socket to square pin adapter, 5.08mm, for high-frequency voltage measurements, 750V DC + AC pk, 1500V peak pulse



4mm-SMA-F

4mm safety banana socket to SMA socket adapter, for high-frequency voltage measurements, 500V DC + AC pk, 1000V peak pulse



4mm-MMCX-F

4mm safety banana socket to MMCX socket adapter, for high-frequency voltage measurements, 250V DC + AC pk, 500V peak pulse



4mm-BNC-F

4mm safety banana socket to BNC socket adapter, for high-frequency voltage measurements, 750V DC + AC pk, 1500V peak pulse



D010031

50Ω BNC feed-through for 1MΩ input oscilloscopes. >500MHz



:

890-880-112

5x Pair of Rail Clip Connectors 4 mm (black, red), 600V CATIII



890-880-115

Pair of Clamps, Hook (black & red) – spare part
1000V CAT II



890-880-114

Pair of Clamps, Jaws (black & red) – spare part
1000V CAT III



890-880-113

Pair of Clamps, Rotating Grip Jaw (black & red) – spare part
1000V CAT II



890-880-108

Pair of Safety Alligator Clips, big (black & red), 1000V CAT III – spare part



890-880-111

Pair of Safety Alligator Clips, small (black & red), 600V CAT III – spare part



890-880-116

4 mm Coupler f-f (red), 30VAC / 60V DC – spare part



890-880-109

Pair of Magnet Connectors 4 mm (black/red), 30VAC / 60V DC -spare part



890-880-103

Pair of Probe Tip Adaptors 4mm to 0.8mm (2x black) – spare part



890-880-106

Pair of Mini Spring Tip Probes 4 mm (black, red), 600V CAT II -spare part



890-808-105

2-Footer – spare part



890-880-102

Set of 4 Spring Tips (fine) – spare part



890-880-101

Set of 10 Contact Pins 0.64mm – spare part



890-880-110

Pair of Spade Terminals, narrow (black / red), 30V AC / 60V DC – spare part



890-880-107

Pair of Spade Terminals, wide (black, red), 30V AC / 60V DC– spare part



Step 3: Select Power Supply

A PMK power supply is required, and available separately.

889-09V-PS2	PS-02, 2ch power supply, with USB interface for remote control, for 100 -240V AC / 50 - 60Hz mains
889-09V-PS2-L	PS-02-L, 2ch power supply, with LAN and USB interface for remote control, for 100 -240V AC / 50 - 60Hz mains
889-09V-PS3	PS-03, 4ch power supply, with USB interface for remote control, for 100 -240V AC / 50 - 60Hz mains
889-09V-PS3-L	PS-03-L, 4ch power supply, with LAN and USB interface for remote control, for 100 -240V AC / 50 - 60Hz mains
889-09V-AP01	AP-01 (battery pack, 1 channel, no remote control)
890-520-915	Power Supply Cable, 1.5 m (0.5m cable included in scope of delivery)

Observe Connector Pin-Out
for PMK power supply cables



The power supply pin assignment is different from other power supplies. Use only original PMK power supplies with PMK probes.

Step 4: Select Positioning System

893-350-010

3D positioner with steel base, 200 mm span width, twin holder, ideal for reliable positioning when the probe's inputs is equipped with spring loaded tips



893-350-015

3D positioner with steel base, 200 mm span width and probe holder



893-350-014

3D positioner with steel base, arm with 200 mm span width and probe head holder, arm with 130 mm span width and twin holder, ideal for reliable positioning of a BumbleBee® or HORNET® series probe when the probe inputs are equipped with spring loaded tips



893-350-013

BumbleBee® or HORNET® series probe head holder – spare part, for use with PMK's SKID positioning system for PCBs and probes



890-880-104

Twin holder M6 – spare part, for use with PMK's SKID positioning system for PCBs and probes



Step 5: Select Accredited Calibration

KAL-DAKKS-BBx

ISO 17025 (re-)calibration

Distribution in the UK & Ireland



**Characterisation,
Measurement &
Analysis**

Lambda Photometrics Limited

Lambda House Batford Mill
Harpenden Herts AL5 5BZ
United Kingdom

E: info@lambdaphoto.co.uk

W: www.lambdaphoto.co.uk

T: +44 (0)1582 764334

F: +44 (0)1582 712084

Copyright © 2024 PMK - All rights reserved.

Information in this publication supersedes that in all previously published material.
Specifications are subject to change without notice.

Informationen in dieser Anleitung ersetzen die in allen bisher veröffentlichten Dokumenten.
Änderungen der Spezifikationen vorbehalten.