



RIGOL

Distribution in the UK & Ireland



Lambda Photometrics Limited

Lambda House Batford Mill

Harpenden Herts AL5 5BZ

United Kingdom

E: info@lambdaphoto.co.uk

W: www.lambdaphoto.co.uk

T: +44 (0)1582 764334

F: +44 (0)1582 712084

DS80000 Series

Digital Oscilloscope

User Guide

Sept. 2024

Guaranty and Declaration

Copyright

© 2024 RIGOL TECHNOLOGIES CO., LTD. All Rights Reserved.

Trademark Information

RIGOL® is the trademark of RIGOL TECHNOLOGIES CO., LTD.

Notices

- RIGOL products are covered by P.R.C. and foreign patents, issued and pending.
- RIGOL reserves the right to modify or change parts of or all the specifications and pricing policies at the company's sole decision.
- Information in this publication replaces all previously released materials.
- Information in this publication is subject to change without notice.
- RIGOL shall not be liable for either incidental or consequential losses in connection with the furnishing, use, or performance of this manual, as well as any information contained.
- Any part of this document is forbidden to be copied, photocopied, or rearranged without prior written approval of RIGOL.

Product Certification

RIGOL guarantees that this product conforms to the national and industrial standards in China as well as the ISO9001:2015 standard and the ISO14001:2015 standard. Other international standard conformance certifications are in progress.

Contact Us

If you have any problem or requirement when using our products or this manual, please contact RIGOL.

E-mail: service@rigol.com

Website: <http://www.rigol.com>

Section	Description	Page
	List of Figures.....	IX
	List of Tables.....	XVI
1	Safety Requirement	1
1.1	General Safety Summary	1
1.2	Safety Notices and Symbols	3
1.3	Measurement Category	3
1.4	Ventilation Requirement	4
1.5	Working Environment	4
1.6	Care and Cleaning	6
1.7	Environmental Considerations	6
1.8	Keep Hands Clear	7
2	Product Features	8
3	Document Overview	10
4	Quick Start	12
4.1	General Inspection	12
4.2	Appearance and Dimensions	13
4.3	To Prepare for Use	14
4.3.1	To Connect to AC Power	14
4.3.2	Turn-on Checkout	14
4.3.3	To Set the System Language	15
4.3.4	To Connect the Probe	15
4.3.5	Function Inspection	17
4.3.6	Probe Compensation	19
4.4	Product Overview	19
4.4.1	Front Panel Overview	20
4.4.2	Rear Panel Overview	23
4.4.3	User Interface	25
4.4.4	Secondary 3.5-inch Touch Screen	27
4.5	Touch Screen Gestures	30
4.5.1	Tap	30
4.5.2	Pinch&Stretch	31
4.5.3	Drag	31
4.5.4	Rectangle Drawing	32

4.6	Parameter Setting Method	34
4.7	To Use the Built-in Help System	39
4.8	To View the Option Information and the Option Installation	40
5	To Set the Vertical System	42
5.1	To Enable or Disable the Analog Channel	42
5.2	To Adjust the Vertical Scale	44
5.3	To Adjust the Vertical Offset	45
5.4	Channel Coupling	46
5.5	BW Limit	46
5.6	Input Impedance	47
5.7	Waveform Invert	47
5.8	Probe	48
5.9	Amplitude Unit	51
5.10	Clear	51
5.11	Channel Delay	51
5.12	Channel Label	52
6	To Set the Horizontal System	53
6.1	To Adjust the Horizontal Time Base	53
6.2	To Adjust the Horizontal Position	54
6.3	Delayed Sweep	55
7	To Set the Sample System	57
7.1	Acquisition Mode	57
7.2	Sampling Mode	58
7.3	Sample Rate	58
7.4	Memory Depth	60
7.5	Horizontal Expansion	61
7.6	Roll Mode	61
7.7	XY Mode	62
8	To Trigger the Oscilloscope	65
8.1	Trigger Source	65
8.2	Trigger Level	66
8.3	Trigger Mode	66
8.4	Trigger Coupling	68
8.5	Trigger Holdoff	68
8.6	Noise Rejection	69
8.7	Trigger Type	69
8.7.1	Edge Trigger	70

8.7.2	Pulse Trigger	71
8.7.3	Slope Trigger	74
8.7.4	Video Trigger	77
8.7.5	Pattern Trigger	80
8.7.6	Duration Trigger	82
8.7.7	Timeout Trigger	85
8.7.8	Runt Trigger	87
8.7.9	Window Trigger	90
8.7.10	Delay Trigger	92
8.7.11	Setup/Hold Trigger	95
8.7.12	Nth Edge Trigger	97
8.7.13	RS232 Trigger (Option)	100
8.7.14	I2C Trigger (Option)	102
8.7.15	SPI Trigger (Option)	106
8.7.16	CAN Trigger (Option)	109
8.7.17	FlexRay Trigger (Option)	113
8.7.18	LIN Trigger (Option)	116
8.7.19	I2S Trigger (Option)	119
8.7.20	MIL-STD-1553 Trigger (Option)	123
8.8	Trigger Output Connector	127
9	Math Operation	128
9.1	Arithmetic Operation	129
9.2	Function Operation	132
9.3	FFT Operation	135
9.4	Logic Operation	140
9.5	Digital Filter	143
10	Measure	148
10.1	Measurement Parameter	148
10.1.1	Time Parameters	148
10.1.2	Count Values	149
10.1.3	Delay and Phase Parameters	151
10.1.4	Voltage Parameters	152
10.1.5	Other Parameters	154
10.2	To Select the Measurement Item	154
10.3	Measurement Settings	156
10.4	Remove the Measurement Results	160
10.5	Auto Measurement	160

10.6	Cursor Measurement	162
10.6.1	Manual Mode	164
10.6.2	Track Mode	168
10.6.3	XY Mode	172
11	Digital Voltmeter (DVM) and Frequency Counter	176
11.1	Digital Voltmeter (DVM)	176
11.1.1	Measurement Settings	177
11.1.2	Remove the Measurement	178
11.2	Frequency Counter	178
11.2.1	Measurement Settings	179
11.2.2	Reset Statistics	180
11.2.3	Remove the Measurement	180
12	Histogram Analysis	181
12.1	To Enable or Disable the Histogram Function	181
12.2	To Select the Histogram Type	182
12.3	To Select the Histogram Source	182
12.4	To Set the Histogram Height	183
12.5	Statistics	183
12.6	To Set the Histogram Range	183
12.7	Histogram Analysis Results	183
13	Real-time Eye Analysis (Option)	186
13.1	To Enable or Disable the Eye Analysis Function	187
13.2	To Select the Source of the Eye Diagram	188
13.3	Threshold Settings	188
13.4	To Set Clock Recovery	189
13.5	To Set the Data Rate	190
13.6	Eye Measurement Result	190
13.7	To Set the Display-related Parameters	192
14	Jitter Analysis (Option)	193
14.1	To Enable or Disable the Jitter Function	194
14.2	To Set Jitter Parameters	194
14.3	To View the Jitter Measurement	195
15	Reference Waveform	198
15.1	To Enable the Reference Waveform	198
15.2	To Set the Reference Waveform	198
15.3	To Set the Reference Waveform Display	199
15.4	Export and Import Operation	200

16	Pass/Fail Test	202
16.1	To Enable or Disable the Pass/Fail Test Function	203
16.2	To Start or Stop the Pass/Fail Test Operation	203
16.3	To Select the Source	203
16.4	Mask	204
16.5	To Set the Output Form of the Test Results	204
16.6	Display of the Statistics of the Test Results	205
17	Protocol Decoding	206
17.1	GPIO Decoding	206
17.1.1	Clock Setting (CLK)	207
17.1.2	Bus Setting	208
17.1.3	Display-related Setting	209
17.1.4	Event Table	209
17.2	UART/RS232 Decoding (Option)	210
17.2.1	Source Setting	212
17.2.2	To Set Data Package	213
17.2.3	Display-related Setting	214
17.2.4	Event Table	214
17.3	I2C Decoding (Option)	215
17.3.1	Source Setting	216
17.3.2	Display-related Setting	218
17.3.3	Event Table	218
17.4	SPI Decoding (Option)	219
17.4.1	To Set the Source	220
17.4.2	To Set Mode and Data	221
17.4.3	Display-related Setting	222
17.4.4	Event Table	222
17.5	LIN Decoding (Option)	223
17.5.1	To Configure the Signal	224
17.5.2	Display-related Setting	225
17.5.3	Event Table	225
17.6	CAN Decoding (Option)	226
17.6.1	To Configure the Signal	227
17.6.2	Display-related Setting	229
17.6.3	Event Table	229
17.7	FlexRay Decoding (Option)	230
17.7.1	Signal Configuration	231

17.7.2	Display-related Setting	232
17.7.3	Event Table	233
17.8	I2S Decoding (Option)	234
17.8.1	Source Setting	235
17.8.2	Bus Setting	235
17.8.3	Display-related Setting	236
17.8.4	Event Table	236
17.9	1553B Decoding (Option)	237
17.9.1	To Set the Data Channel Source and the Threshold	238
17.9.2	Display-related Setting	238
17.9.3	Event Table	239
17.10	USB2.0 Decoding (Option)	240
17.10.1	Signal Configuration	241
17.10.2	Display-related Setting	242
17.10.3	Event Table	242
18	Serial Bus Compliance Analysis (Option)	244
18.1	USB2.0 Compliance Analysis (Option)	244
18.1.1	DUT	244
18.1.2	Test Selection	246
18.1.3	Analysis Setting	249
18.1.4	Result Export	250
18.2	LAN Compliance Analysis (Option)	252
18.2.1	To Select the Signal Type	253
18.2.2	To Select the Test Item	254
18.2.2.1	100Base-T Signal Test Items	254
18.2.2.2	1000Base-T Signal Test Items	255
18.2.3	Configuration Menu	260
18.2.3.1	To Configure the Source	260
18.2.3.2	Fixture Calibration	262
18.2.3.3	To Launch the Test	264
18.2.4	Result Report	265
19	Multi-pane Windowing	268
20	Waveform Recording and Playing	270
20.1	Common Settings	270
20.2	Record Options	271
20.3	Play Options	272
21	Search and Navigation Function	274

21.1 Search Function	274
21.2 Navigation Function	277
22 Display Control	281
22.1 Display Type	281
22.2 Persistence Time	282
22.3 To Set the Screen Grid	282
22.4 Display Setting	283
22.5 Show Scale	283
22.6 Color Grade	283
22.7 Waveform Freeze	284
23 Storage	285
23.1 To Save a File	285
23.1.1 To Save Image	285
23.1.2 To Save Wave	287
23.1.3 Save Setup	289
23.1.4 Binary Data Format (.bin)	290
23.2 To Load a File	293
23.3 System Upgrade	294
23.4 Disk Management	295
23.5 Factory Settings	297
24 System Utility Function Setting	306
24.1 I/O Setting	306
24.2 Basic Settings	308
24.3 About this Oscilloscope	311
24.4 Other Settings Related to the System Utility	311
24.5 Auto Config	312
24.6 SelfCal	312
24.7 Option List	313
24.8 Quick Operation	313
24.9 Self-check	316
24.10 Demonstration Signals	318
25 Remote Control	320
25.1 Remote Control via USB	321
25.2 Remote Control via LAN	321
25.3 Remote Control via GPIB	322
26 Troubleshooting	324
27 Appendix	326

27.1 Appendix A: Options and Accessories	326
27.2 Appendix B: Warranty	327

List of Figures

Figure 4.1 Front View (Unit: mm)	13
Figure 4.2 Side View (Unit: mm)	13
Figure 4.3 To Connect to AC Power	14
Figure 4.4 To Connect the Passive Probe	16
Figure 4.5 To Connect the Probe Head to the PA of the Active Probe	16
Figure 4.6 To Connect the Active Probe	17
Figure 4.7 To Use the Compensation Signal	18
Figure 4.8 Waveform Signal	18
Figure 4.9 Probe Compensation	19
Figure 4.10 DS80000 Front Panel	20
Figure 4.11 DS80000 Rear Panel	23
Figure 4.12 DS80000 User Interface	25
Figure 4.13 Smart Quick-Responsive Shortcut Key Menu Display	27
Figure 4.14 Flip Screen Adjustment Interface	29
Figure 4.15 Tap Gesture	31
Figure 4.16 Pinch&Stretch Gesture	31
Figure 4.17 Drag Gesture	32
Figure 4.18 Rectangle Drawing Gesture (a)	33
Figure 4.19 Rectangle Drawing Gesture (b)	33
Figure 4.20 English Input Interface	35
Figure 4.21 Chinese Input Interface	36
Figure 4.22 String Keypad	37
Figure 4.23 Numeric Keypad	39
Figure 5.1 Vertical Menu for Channel	42
Figure 5.2 Waveform Invert	47
Figure 5.3 Probe Setting Menu	48
Figure 5.4 RP7000/PVA7000/PVA8000 Probe Setting Menu	49

Figure 5.5 SelfCal	50
Figure 5.6 Zero Offset	52
Figure 6.1 Horizontal System Menu	53
Figure 6.2 Delayed Sweep Mode	56
Figure 7.1 Memory Depth	60
Figure 7.2 XY Setting Menu	63
Figure 7.3 Measurement Schematic Diagram of Phase Deviation	64
Figure 8.1 Schematic Diagram of the Acquisition Memory	67
Figure 8.2 Trigger Holdoff	69
Figure 8.3 Edge Trigger Setting Menu	70
Figure 8.4 Positive Pulse Width/Negative Pulse Width	72
Figure 8.5 Pulse Trigger Setting Menu	72
Figure 8.6 Positive Slope Time/Negative Slope Time	74
Figure 8.7 Slope Trigger Setting Menu	75
Figure 8.8 Video Trigger Setting Menu	77
Figure 8.9 Pattern Trigger	80
Figure 8.10 Pattern Trigger Setting Menu	80
Figure 8.11 Duration Trigger	83
Figure 8.12 Duration Trigger Setting Menu	83
Figure 8.13 Timeout Trigger	85
Figure 8.14 Timeout Trigger Menu	86
Figure 8.15 Runt Trigger	87
Figure 8.16 Runt Trigger Setting Menu	88
Figure 8.17 Window Trigger Setting Menu	90
Figure 8.18 Delay Trigger	92
Figure 8.19 Delay Trigger Setting Menu	92
Figure 8.20 Setup/Hold Trigger	95
Figure 8.21 Setup/Hold Trigger Setting Menu	95
Figure 8.22 Nth Edge Trigger	98

Figure 8.23 Nth Edge Trigger Setting Menu	98
Figure 8.24 Schematic Diagram of RS232 Protocol	100
Figure 8.25 RS232 Trigger Setting Menu	100
Figure 8.26 Schematic Diagram of I2C Protocol	102
Figure 8.27 I2C Trigger Setting Menu	103
Figure 8.28 Bin Format Setting	105
Figure 8.29 Hex Format Setting	105
Figure 8.30 Sequential Chart of SPI Bus	107
Figure 8.31 SPI Trigger Setting Menu	107
Figure 8.32 Data Frame Format of the CAN Bus	109
Figure 8.33 CAN Trigger Setting Menu	110
Figure 8.34 Sample Position	111
Figure 8.35 Frame Format of FlexRay Bus	113
Figure 8.36 FlexRay Trigger Setting Menu	114
Figure 8.37 Data Frame Format of the LIN Bus	116
Figure 8.38 LIN Trigger Setting Menu	117
Figure 8.39 Sample Position	118
Figure 8.40 Sequential Chart of I2S Bus	120
Figure 8.41 I2S Trigger Setting Menu	120
Figure 8.42 Formats of the Command Word, Data Word, and Status Word of the 1553B Bus	124
Figure 8.43 MIL-STD-1553 Trigger Setting Menu	124
Figure 9.1 Math Operation Menu	128
Figure 9.2 Operation Result Display Window	129
Figure 9.3 Arithmetic Operation Menu	130
Figure 9.4 Operation Result Display Window	130
Figure 9.5 Function Operation Menu	133
Figure 9.6 Operation Result Display Window	133
Figure 9.7 FFT Operation Menu	136

Figure 9.8 FFT Operation Window	136
Figure 9.9 Peak Search	139
Figure 9.10 Logic Operation Menu	140
Figure 9.11 Operation Result Display Window	142
Figure 9.12 Digital Filter Menu	144
Figure 9.13 Operation Result Display Window	145
Figure 10.1 Time Parameters	148
Figure 10.2 Delay and Phase Parameters	151
Figure 10.3 Voltage Parameters	152
Figure 10.4 Vertical Measurement Items	155
Figure 10.5 Horizontal Measurement Items	155
Figure 10.6 Other Measurement Items	156
Figure 10.7 Measurement Settings	157
Figure 10.8 Cursor	162
Figure 10.9 Cursor Measurement Result	163
Figure 10.10 Manual Mode Setting Menu	165
Figure 10.11 Manual Cursor Measurement Example	168
Figure 10.12 Track Mode Setting Menu	169
Figure 10.13 Track Measurement (before Horizontal Expansion)	171
Figure 10.14 Track Measurement (after Horizontal Expansion)	172
Figure 10.15 XY Mode	173
Figure 11.1 DVM Setting Menu	177
Figure 11.2 Frequency Counter Setting Menu	179
Figure 12.1 Histogram Setting Menu	181
Figure 12.2 Histogram Analysis Results	184
Figure 13.1 Eye Diagram Setting Menu	187
Figure 13.2 Eye Measurement Result	188
Figure 13.3 Diagram of Eye Measurement Parameters	192
Figure 14.1 Jitter Setting Menu	193

Figure 15.1 Reference Waveform Menu	198
Figure 16.1 Pass/Fail Test Menu	202
Figure 16.2 Minimized Pass/Fail Test Window	203
Figure 17.1 Schematic Diagram of GPIO Decoding	207
Figure 17.2 GPIO Decoding Menu	207
Figure 17.3 Parallel Decoding Event Table	210
Figure 17.4 Schematic Diagram of UART/RS232 Serial Bus	211
Figure 17.5 Schematic Diagram of Negative Logic	211
Figure 17.6 UART/RS232 Decoding Menu	212
Figure 17.7 UART/RS232 Decoding Event Table	215
Figure 17.8 I2C Serial Bus	215
Figure 17.9 I2C Decoding Menu	216
Figure 17.10 I2C Decoding Event Table	218
Figure 17.11 SPI Serial Bus	219
Figure 17.12 SPI Decoding Menu	220
Figure 17.13 SPI Decoding Event Table	223
Figure 17.14 LIN Decoding Menu	224
Figure 17.15 LIN Decoding Event Table	225
Figure 17.16 CAN Decoding Menu	227
Figure 17.17 Sample Position	228
Figure 17.18 CAN Decoding Event Table	229
Figure 17.19 FlexRay Decoding Menu	231
Figure 17.20 Sample Position	232
Figure 17.21 FlexRay Decoding Event Table	233
Figure 17.22 I2S Decoding Menu	234
Figure 17.23 I2S Decoding Event Table	237
Figure 17.24 1553B Decoding Menu	238
Figure 17.25 1553B Decoding Event Table	239
Figure 17.26 USB Topology	241

Figure 17.27 USB2.0 Decoding Event Table	242
Figure 18.1 USB2.0 Test Model	246
Figure 18.2 USB2.0 Signal Quality Compliance Analysis Test Result	251
Figure 18.3 Signal Type	253
Figure 18.4 100Base-T Signal Test Items	254
Figure 18.5 1000Base-T Signal Test Items	256
Figure 18.6 Typical Waveform of Test Mode 1 Signal	257
Figure 18.7 Configuration Menu	260
Figure 18.8 Fixture Calibration	263
Figure 18.9 LAN Compliance Analysis Test Report	266
Figure 19.1 "Add Window" Menu	268
Figure 20.1 Waveform Recording Menu	270
Figure 20.2 Play Operation Interface	272
Figure 21.1 Search Menu	275
Figure 21.2 Marker Table	277
Figure 21.3 Navigation Menu	278
Figure 21.4 Navigation Menu-Simple Mode	278
Figure 21.5 Search Event Navigation Interface	279
Figure 22.1 Display Setting Menu	281
Figure 22.2 Vector Display	282
Figure 23.1 Save Image Menu	286
Figure 23.2 Save Wave Menu	288
Figure 23.3 Save Setup Menu	289
Figure 23.4 Load Setting Menu	294
Figure 23.5 Upgrade Menu	295
Figure 23.6 Disk Management Interface	296
Figure 24.1 Self-calibration Menu	313
Figure 24.2 Quick Operation Setting Menu	314
Figure 24.3 Key Test Interface	316

Figure 24.4 Touch Screen Test Interface	317
Figure 24.5 Touch-Enabled Gesture Operation Interface	317
Figure 24.6 Board Test Interface	318
Figure 24.7 Demonstration Signals Menu	319
Figure 25.1 Search for the Available Device	323
Figure 25.2 Confirm the Available Device	323

List of Tables

Table 5.1 BW Limit	46
Table 8.1 Video Standard	78
Table 9.1 Window Function	138
Table 9.2 Logic Operation	141
Table 17.1 Bus Setting	208
Table 18.1 High-speed Signal Quality Compliance Test Item	247
Table 18.2 Full-speed Signal Quality Compliance Test Item	247
Table 18.3 Low-speed Signal Quality Compliance Test Item	248
Table 18.4 Signal Configuration	250
Table 18.5 Pass Conditions for the Test Items of the 100Base-T Signal Type ..	254
Table 18.6 Pass Conditions for Test Mode 1	257
Table 18.7 Pass Conditions for Test Mode 2	258
Table 18.8 Pass Conditions for Test Mode 3	259
Table 18.9 Pass Conditions for Test Mode 4	260
Table 23.1 BIN File Format	290
Table 23.2 File Header	291
Table 23.3 Waveform Header	291
Table 23.4 Waveform Data Header	293
Table 23.5 Factory Settings	298

1 Safety Requirement

1.1 General Safety Summary

Please review the following safety precautions carefully before putting the instrument into operation so as to avoid any personal injury or damage to the instrument and any product connected to it. To prevent potential hazards, please follow the instructions specified in this manual to use the instrument properly.

- **Use Proper Power Cord.**

Only the exclusive power cord designed for the instrument and authorized for use within the local country could be used.

- **Ground the Instrument.**

The instrument is grounded through the Protective Earth lead of the power cord. To avoid electric shock, it is essential to connect the earth terminal of the power cord to the Protective Earth terminal before connecting any inputs or outputs.

- **Connect the Probe Correctly.**

If a probe is used, the probe ground lead must be connected to earth ground. Do not connect the ground lead to high voltage. Improper way of connection could result in dangerous voltages being present on the connectors, controls or other surfaces of the oscilloscope and probes, which will cause potential hazards for operators.

- **Observe All Terminal Ratings.**

To avoid fire or shock hazard, observe all ratings and markers on the instrument and check your manual for more information about ratings before connecting the instrument.

- **Use Proper Overvoltage Protection.**

Ensure that no overvoltage (such as that caused by a bolt of lightning) can reach the product. Otherwise, the operator might be exposed to the danger of an electric shock.

- **Do Not Operate Without Covers.**

Do not operate the instrument with covers or panels removed.

- **Do Not Insert Objects Into the Air Outlet.**

Do not insert anything into the holes of the fan to avoid damaging the instrument.

- **Use Proper Fuse.**

Please use the specified fuses.

- **Avoid Circuit or Wire Exposure.**

Do not touch exposed junctions and components when the unit is powered on.
- **Do Not Operate With Suspected Failures.**

If you suspect damage occurs to the instrument, have it inspected by RIGOL authorized personnel before further operations. Any maintenance, adjustment or replacement especially to circuits or accessories must be performed by RIGOL authorized personnel.
- **Provide Adequate Ventilation.**

Inadequate ventilation may cause an increase of temperature in the instrument, which would cause damage to the instrument. So please keep the instrument well ventilated and inspect the air outlet and the fan regularly.
- **Do Not Operate in Wet Conditions.**

To avoid short circuit inside the instrument or electric shock, never operate the instrument in a humid environment.
- **Do Not Operate in an Explosive Atmosphere.**

To avoid personal injuries or damage to the instrument, never operate the instrument in an explosive atmosphere.
- **Keep Instrument Surfaces Clean and Dry.**

To avoid dust or moisture from affecting the performance of the instrument, keep the surfaces of the instrument clean and dry.
- **Prevent Electrostatic Impact.**

Operate the instrument in an electrostatic discharge protective environment to avoid damage induced by static discharges. Always ground both the internal and external conductors of cables to release static before making connections.
- **Use the Battery Properly.**

Do not expose the battery (if available) to high temperature or fire. Keep it out of the reach of children. Improper change of a battery (lithium battery) may cause an explosion. Use the RIGOL specified battery only.
- **Handle with Caution.**

Please handle with care during transportation to avoid damage to keys, knobs, interfaces, and other parts on the panels.

**WARNING**

Equipment meeting Class A requirements may not offer adequate protection to broadcast services within residential environment.

1.2 Safety Notices and Symbols

Safety Notices in this Manual:



WARNING

Indicates a potentially hazardous situation or practice which, if not avoided, will result in serious injury or death.



CAUTION

Indicates a potentially hazardous situation or practice which, if not avoided, could result in damage to the product or loss of important data.

Safety Notices on the Product:

- **DANGER**

It calls attention to an operation, if not correctly performed, could result in injury or hazard immediately.

- **WARNING**

It calls attention to an operation, if not correctly performed, could result in potential injury or hazard.

- **CAUTION**

It calls attention to an operation, if not correctly performed, could result in damage to the product or other devices connected to the product.

Safety Symbols on the Product:



Hazardous Voltage



Safety Warning



Protective Earth Terminal

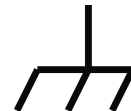

Chassis Ground



Test Ground

1.3 Measurement Category

Measurement Category

This instrument can make measurements in Measurement Category I.



WARNING

This instrument can only be used for measurements within its specified measurement categories.

Measurement Category Definitions

- **Measurement category I** is for measurements performed on circuits not directly connected to MAINS. Examples are measurements on circuits not derived from MAINS, and specially protected (internal) MAINS derived circuits. In the latter case, transient stresses are variable. Thus, you must know the transient withstand capability of the equipment.
- **Measurement category II** is for measurements performed on circuits directly connected to low voltage installation. Examples are measurements on household appliances, portable tools and similar equipment.
- **Measurement category III** is for measurements performed in the building installation. Examples are measurements on distribution boards, circuit-breakers, wiring (including cables, bus-bars, junction boxes, switches and socket-outlets) in the fixed installation, and equipment for industrial use and some other equipment. For example, stationary motors with permanent connection to a fixed installation.
- **Measurement category IV** is for measurements performed at the source of a low-voltage installation. Examples are electricity meters and measurements on primary overcurrent protection devices and ripple control units.

1.4 Ventilation Requirement

This instrument uses a fan to force cooling. Please make sure that the air inlet and outlet areas are free from obstructions and have free air. When using the instrument in a bench-top or rack setting, provide at least 10 cm clearance beside, above and behind the instrument for adequate ventilation.



CAUTION

Inadequate ventilation may cause an increase of temperature in the instrument, which would cause damage to the instrument. So please keep the instrument well ventilated and inspect the air outlet and the fan regularly.

1.5 Working Environment

Temperature

Operating: 0°C to +50°C

Non-operating: -30°C to +70°C

Humidity

- **Operating:**
 - Below +30°C: ≤90% RH (without condensation)
 - +30°C to +40°C: ≤75% RH (without condensation)

+40°C to +50°C: ≤45% RH (without condensation)

- **Non-operating:**

Below +65°C: ≤90% RH (without condensation)



WARNING

To avoid short circuit inside the instrument or electric shock, never operate the instrument in a humid environment.

Altitude

- **Operating:** below 3 km
- **Non-operating:** below 15 km

Protection Level Against Electric Shock

ESD ±8kV

Installation (Overvoltage) Category

This product is powered by mains conforming to installation (overvoltage) category II.



WARNING

Ensure that no overvoltage (such as that caused by a bolt of lightning) can reach the product. Otherwise, the operator might be exposed to the danger of an electric shock.

Installation (Overvoltage) Category Definitions

Installation (overvoltage) category I refers to signal level which is applicable to equipment measurement terminals connected to the source circuit. Among these terminals, precautions are done to limit the transient voltage to a low level.

Installation (overvoltage) category II refers to the local power distribution level which is applicable to equipment connected to the AC line (AC power).

Pollution Degree

Pollution Degree 2

Pollution Degree Definition

- **Pollution Degree 1:** No pollution or only dry, nonconductive pollution occurs. The pollution has no effect. For example, a clean room or air-conditioned office environment.
- **Pollution Degree 2:** Normally only nonconductive pollution occurs. Temporary conductivity caused by condensation is to be expected. For example, indoor environment.
- **Pollution Degree 3:** Conductive pollution or dry nonconductive pollution that becomes conductive due to condensation occurs. To be found in industrial

environment or construction sites (harsh environments). For example, sheltered outdoor environment.

- **Pollution Degree 4:** The pollution generates persistent conductivity caused by conductive dust, rain, or snow. For example, outdoor areas.

Safety Class

Class 1 – Grounded Product

1.6 Care and Cleaning

Care

Do not store or leave the instrument where it may be exposed to direct sunlight for long periods of time.

Cleaning

Clean the instrument regularly according to its operating conditions.

1. Disconnect the instrument from all power sources.
2. Clean the external surfaces of the instrument with a soft cloth dampened with mild detergent or water. Avoid having any water or other objects into the chassis via the heat dissipation hole. When cleaning the LCD, take care to avoid scarifying it.



CAUTION

To avoid damage to the instrument, do not expose it to caustic liquids.



WARNING

To avoid short-circuit resulting from moisture or personal injuries, ensure that the instrument is completely dry before connecting it to the power supply.

1.7 Environmental Considerations

The following symbol indicates that this product complies with the WEEE Directive 2012/19/EU.



The equipment may contain substances that could be harmful to the environment or human health. To avoid the release of such substances into the environment and avoid harm to human health, we recommend you to recycle this product appropriately to ensure that most materials are reused or recycled properly. Please contact your local authorities for disposal or recycling information.

You can click on the following link <https://int.rigol.com/services/services/declaration> to download the latest version of the RoHS&WEEE certification file.

1.8 Keep Hands Clear



WARNING

While the main screen is opening or closing, keep hands clear from the inclination angle between the main screen and its instrument body to avoid being pinched.

2 Product Features

Product Features

- Built on RIGOL's brand new core module
- 4 analog channels, 1 EXT channel
- Analog channel bandwidth: Max. 13 GHz
- Up to 40 GSa/s sample rate
- Max. 2 Gpts or 4 Gpts memory depth (opt.)
- Max. waveform capture rate: 250,000 wfms/s
- Vertical resolution: 8-16 bits adjustable
- Vertical sensitivity range: 1 mV/div ~ 1 V/div (50Ω)
- Timebase range: 20 ps/div~1 ks/div
- N-in-1 instrument, including digital oscilloscope, digital voltmeter, 8-digit frequency counter and totalizer, and protocol analyzer (option)
- Various trigger functions: Zone trigger, Edge trigger, Pulse trigger, Slopetrigger, Video trigger, Pattern trigger, Duration trigger, Timeout trigger, Runtrigger, Window trigger, Delay trigger, Setup/Hold trigger, Nth Edge trigger, RS232/UART, I2C, SPI, CAN, FlexRay, LIN, I2S, and MIL-STD-1553
- Various serial bus decodings (opt.): RS232/UART, I2C, SPI, CAN, CAN-FD, FlexRay, LIN, I2S, MIL-STD-1553, USB2.0; 4 decode channels
- Support Ethernet, USB2.0, and other protocol compliance analysis functions
- Auto measurement of 41 waveform parameters; full-memory hardware measurement function
- Various math operations: A+B, A-B, A×B, A/B, FFT, A&&B, A||B, A^B, !A, Intg, Diff, Sqrt, Lg, Ln, Exp, Abs, AX+B, LowPass, HighPass, BandPass, and BandStop built-in peak search functions
- Real-time eye diagram and jitter analysis (opt.)
- Recording and playback functions for a maximum of 2,000,000 frames of hardware real-time and ceaseless waveforms
- Multiple interfaces available: USB HOST&DEVICE, LAN(LXI), HDMI, AUX OUT; Web Control supported
- 15.6" HD capacitive multi-touch screen with one-button electronic tilt; multi-pane windowing
- The photoelectric encoder operating knob prolongs its service life, guaranteeing more than 100,000 times of pressing operation and 1 million times of rotation operation, greatly improving its service life
- High-definition smart and quick-responsive shortcut menu display
- Support online upgrade

Product Features

DS80000 series high-bandwidth real-time digital oscilloscope is the 8th generation of RIGOL's self-developed oscilloscopes. It provides 13 GHz analog bandwidth, 40 GSa/s real-time sample rate, 4 Gpts memory depth, and up to 250,000 wfms/s capture rate. It supports the compliance analysis of various protocols, helping you locate the problem in high-speed design and address the verification problem.

3 Document Overview

This manual gives you a quick review about the front and rear panel of DS80000 series, the user interface, and the basic operation method.



TIP

For the latest version of this manual, download it from the official website of RIGOL (<http://www.rigol.com>).

Publication Number

UGA38100-1110

Software Version

00.00.03

Software upgrade might change or add product features. Please acquire the latest version of the manual from RIGOL website or contact RIGOL to upgrade the software.

Format Conventions in this Manual

1. Key

The front panel key is denoted by the menu key icon. For example, indicates the "Default" key.



2. Menu

The menu item is denoted by the format of "Menu Name (Bold) + Character Shading" in the manual. For example, **Setup** indicates clicking or tapping the "Setup" sub-menu under the "Utility" function menu to view the basic settings for the instrument.



3. Operation Procedures





The next step of the operation is denoted by ">" in the manual. For example,



> **Storage** indicates that first clicking or tapping the icon , then clicking or tapping **Storage**.

4. Knob

Label	Description	Label	Description
 Channel	Channel On/Off Key	 Multifunction	Multifunction Key

Label	Description	Label	Description
 <u>Multifunction</u>	Multifunction Knob	 <u>Multifunction</u>	Multifunction Knob
 <u>SCALE</u>	Channel Vertical Scale Knob	 <u>OFFSET</u>	Channel Vertical Offset Knob

Content Conventions in this Manual

DS80000 series includes the following models. Unless otherwise specified, this manual takes DS81304 as an example to introduce DS80000 series and its basic operations.

Model	Max. Analog Bandwidth	No. of Analog Channels	Sample Rate
DS81304	13 GHz	4	Full-channel ^[1] : 40 GSa/s
DS81004	10 GHz	4	Full-channel ^[1] : 40 GSa/s
DS80804	8 GHz	4	Full-channel ^[1] : 40 GSa/s
DS80604	6 GHz	4	Full-channel ^[1] : 40 GSa/s

NOTE

[1]: CH1, CH2, CH3, and CH4 channels are independent of each other. Whatever one or multiple channels are enabled, the maximum specifications of the instrument can be reached.



4 Quick Start

4.1 General Inspection

1. Inspect the packaging

If the packaging has been damaged, do not dispose the damaged packaging or cushioning materials until the shipment has been checked for completeness and has passed both electrical and mechanical tests.

The consigner or carrier shall be liable for the damage to the instrument resulting from shipment. RIGOL would not be responsible for free maintenance/rework or replacement of the instrument.

2. Inspect the instrument

In case of any mechanical damage, missing parts, or failure in passing the electrical and mechanical tests, contact your RIGOL sales representative.

3. Check the accessories

Please check the accessories according to the packing lists. If the accessories are damaged or incomplete, please contact your RIGOL sales representative.

Recommended Calibration Interval

RIGOL suggests that the instrument should be calibrated every 18 months.

4.2 Appearance and Dimensions

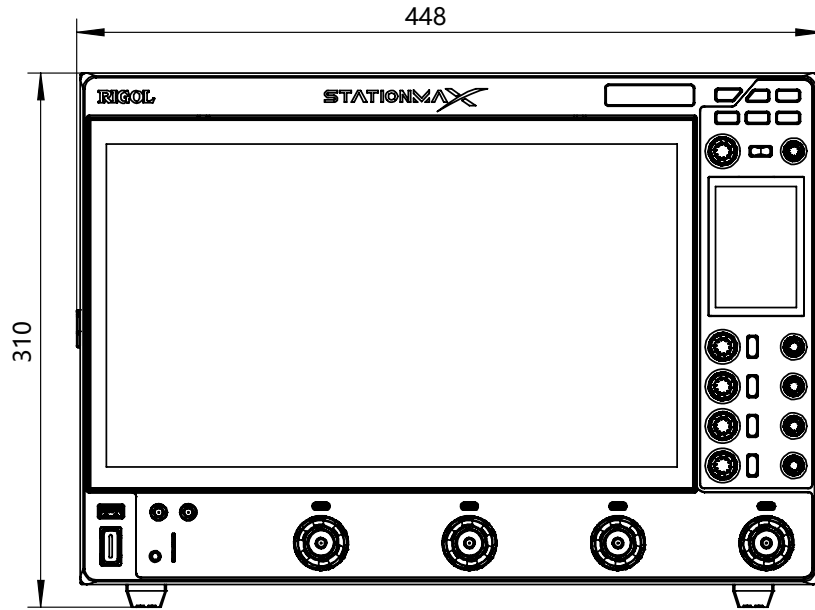

Figure 4.1 Front View (Unit: mm)

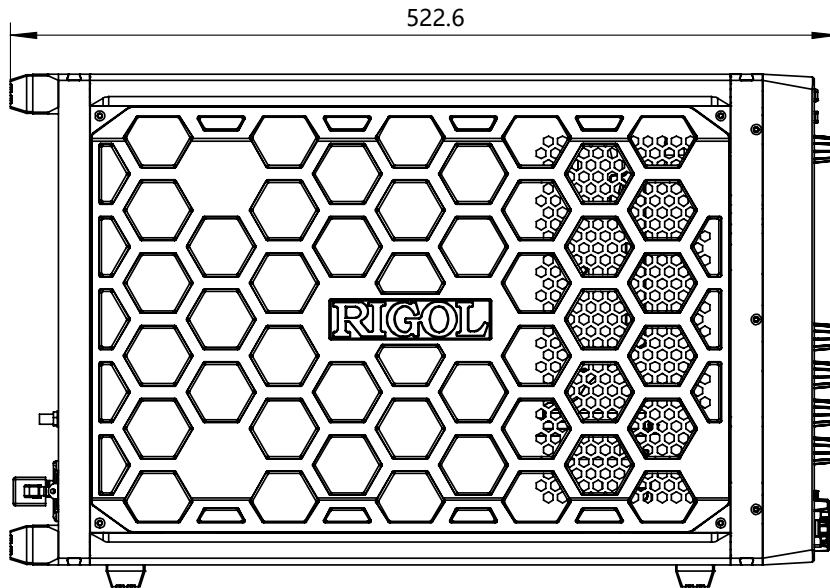

Figure 4.2 Side View (Unit: mm)

4.3 To Prepare for Use

4.3.1 To Connect to AC Power

The power requirements of the oscilloscope are 100~127 V, 200~240 V, 50/60 Hz. Please use the power cord provided in the accessories to connect the instrument to the AC power source.

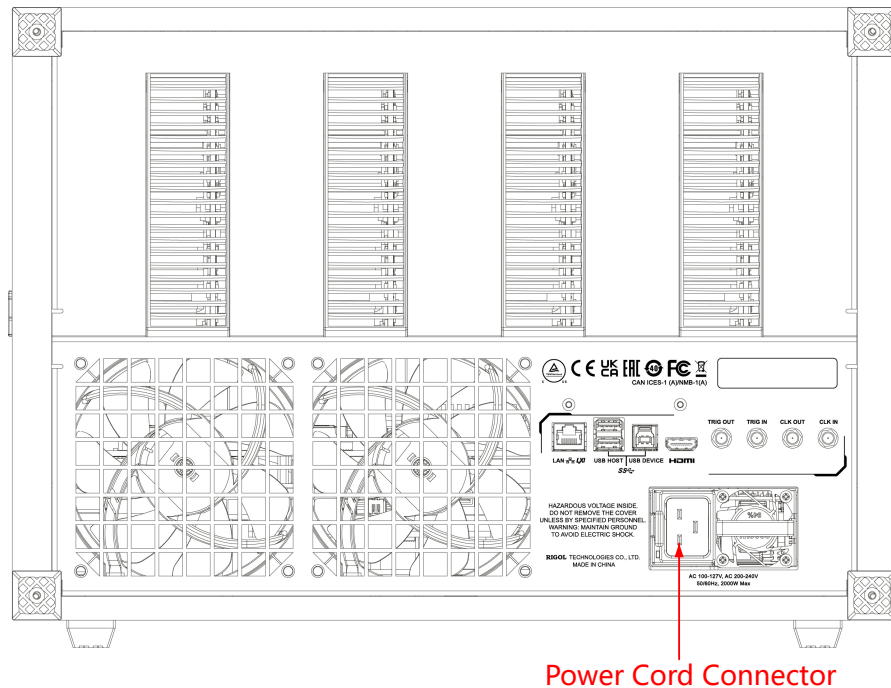



Figure 4.3 To Connect to AC Power







WARNING

To avoid electric shock, ensure that the instrument is correctly grounded.

4.3.2 Turn-on Checkout

After the instrument is connected to the power source, press the power key  at the lower-left corner of the front panel to power on the instrument. During the start-up process, the instrument performs a series of self-tests. After the self-test, the splash screen is displayed.

- **Restart:** Click or tap  > **Restart**. Then a prompt message "Are you sure to reboot?" is displayed. Click or tap **OK** to restart the instrument.
- **Shutdown:**

- Click or tap  > **Shutdown**. Then a prompt message "Are you sure to shutdown?" is displayed. Click or tap **OK** to shut down the instrument.
- Press the power key  and a prompt message "Are you sure to shutdown?" is displayed. Click or tap **OK** to shut down the instrument.
- Press  twice to directly shut down the instrument.
- Press  for three seconds to directly shut down the instrument.

TIP

You can also click or tap  > **Utility** > **Setup**, then select "Switch On" under the "Power Status" menu. After this setting, the instrument powers on once connected to power.

4.3.3 To Set the System Language

This oscilloscope supports multiple languages. You can click or tap  > **Utility** > **Setup** > **Language** to select the system language.

4.3.4 To Connect the Probe

RIGOL provides the passive and active probes for the DS80000 series. For specific probe models, please refer to *DS80000 Data Sheet*. For detailed technical information of the probes, please refer to the corresponding Probe User Guide.

Connect the Passive Probe

Take RP3500A (passive high-impedance probe) as an example.

1. Connect the BNC terminal of the probe to an analog channel input terminal on the front panel of the oscilloscope, as shown in *Figure 4.4*.
2. Connect the ground alligator clip or spring of the probe to the circuit ground terminal, and then connect the probe tip to the circuit point to be tested.

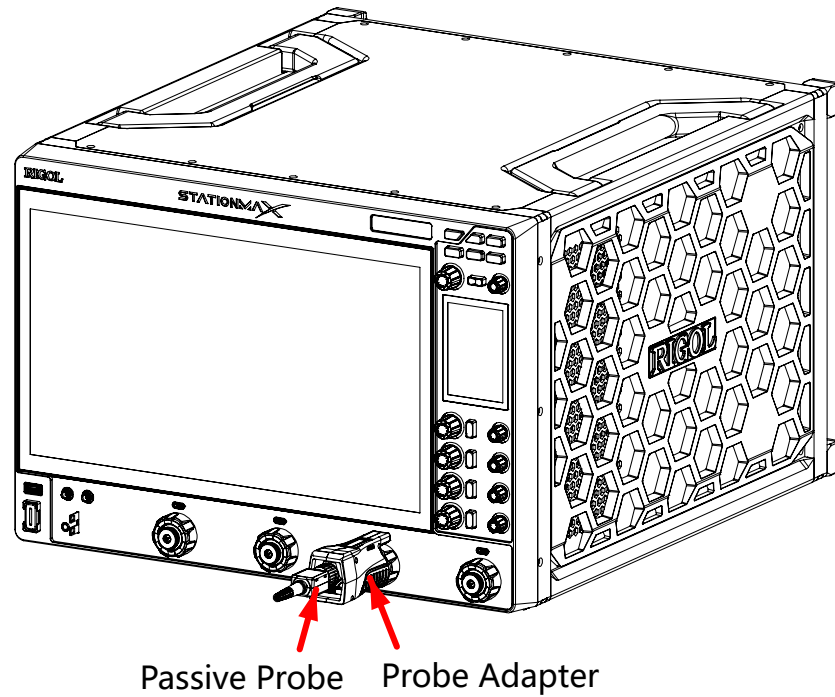

Figure 4.4 To Connect the Passive Probe

After you connect the passive probe, check the probe function and probe compensation adjustment before making measurements. For detailed procedures, refer to *Function Inspection* and *Probe Compensation*.

Connect the Active Probe

Take PVA8000 (active differential probe) as an example.

1. Connect the probe head to the preamp of the active probe, as shown in *Figure 4.5*.

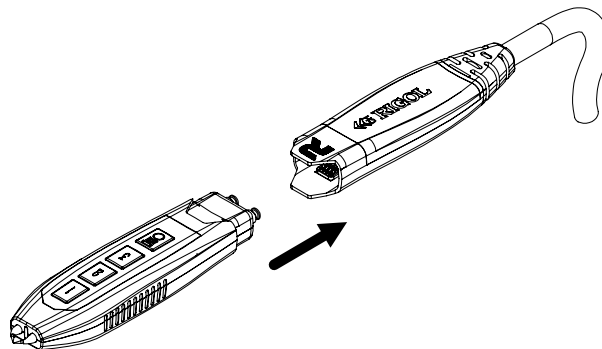

Figure 4.5 To Connect the Probe Head to the PA of the Active Probe

2. Connect the other end of the preamp to an analog channel input terminal on the front panel of the oscilloscope via the probe converter, as shown in *Figure 4.6*.

Note that you need to push the probe to the due position to lock it firmly.

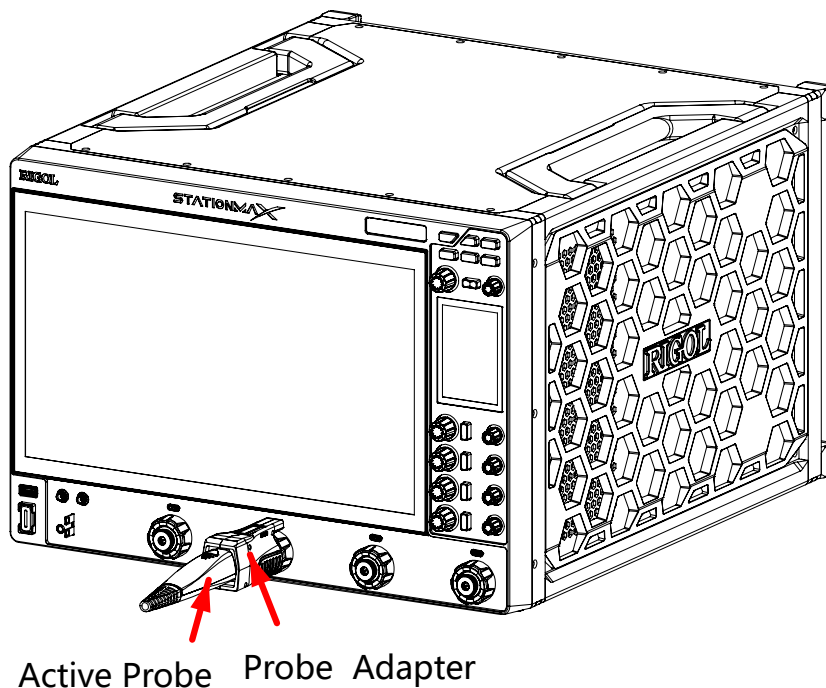

Figure 4.6 To Connect the Active Probe

3. Use the probe's auxiliary device to connect the probe head to the circuit under test. For detailed information of the probes, please refer to *User Guide for PVA8000 Series Active Probe*.

After connecting the active probe, you can perform probe calibration and offset voltage adjustment if necessary. For detailed procedures, refer to the *User Guide* of this instrument.

4.3.5 Function Inspection

1. Press on the front panel, then a prompt message displaying "Restore default settings?" appears on the screen. Click **OK** to restore the instrument to its factory default settings.
2. Connect the ground alligator clip of the probe to "Ground Terminal", as shown in *Figure 4.7* below.

3. Use the probe to connect the input terminal of CH1 of the oscilloscope and the "Compensation Signal Output Terminal" of the probe, as shown in *Figure 4.7*.

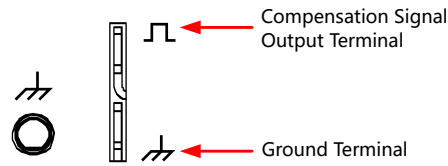



Figure 4.7 To Use the Compensation Signal

4. Set the probe ratio based on the attenuation of the probe, and then click  >

Auto.

5. Observe the waveform on the display. In normal condition, the square waveform as shown in the figure below should be displayed.

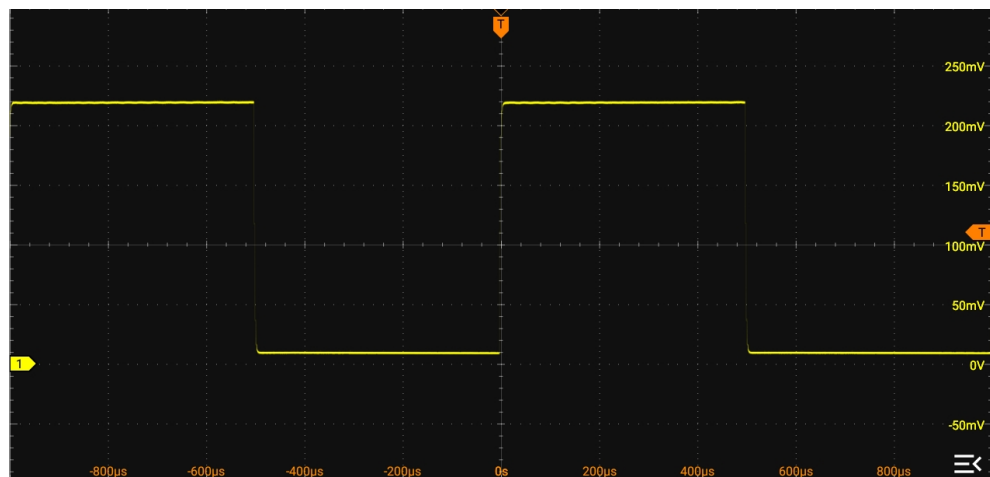

Figure 4.8 Waveform Signal

6. Use the same method to test the other channels. If the square waveforms actually shown do not match that in the figure above, please perform "**Probe Compensation**" introduced in the next section.



WARNING

To avoid electric shock when using the probe, please make sure that the insulated wire of the probe is in good condition. Do not touch the metallic part of the probe when the probe is connected to high voltage source.

4.3.6 Probe Compensation

When used for the first time, the oscilloscope probe must be compensated to match the input characteristics of the oscilloscope channel to which it is connected. The non-compensated or poorly compensated probe may cause measurement errors. The compensation procedure is as follows:

1. Perform Step 1, 2, 3 and 4 in **Function Inspection**.
2. Check the displayed waveforms and compare them with the waveforms shown in

Figure 4.9.

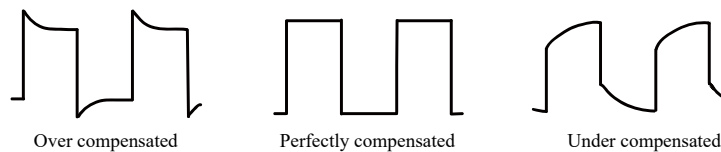

Figure 4.9 Probe Compensation

3. Use the probe compensation adjustment tool provided in the accessories to adjust the low-frequency compensation adjustment hole on the probe until the displayed waveform is consistent with the "Perfectly compensated" waveform shown in the above figure.

4.4 Product Overview

DS80000 series high-bandwidth real-time digital oscilloscope is the 8th generation of RIGOL's self-developed digital oscilloscope. It provides 13 GHz analog bandwidth, max. 40 Gsa/s real-time sample rate, and max. 4 Gpts memory depth per channel. In addition, the DS80000 series supports the compliance analysis of various protocols, enabling you to locate the problem in high-speed design and address the verification problem.

4.4.1 Front Panel Overview

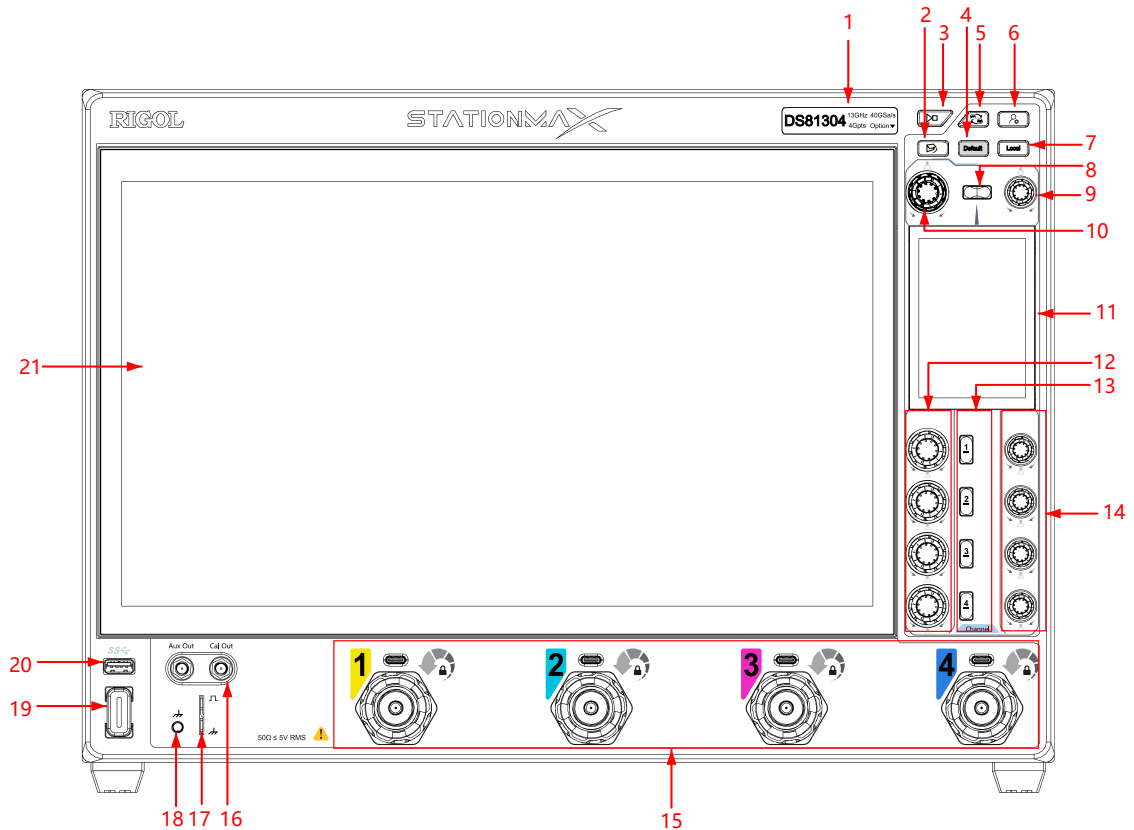

Figure 4.10 DS80000 Front Panel

1. Electronic Label

The product model and its main parameters displayed on the electronic label, sustaining its contents up to 20 years even at power-off state. The parameters will be updated automatically after upgrade to keep the information displayed on the electronic label consistent with that of the current instrument.

2. Screen Tilt Adjustment Key

Controls whether to adjust the tilt of the large and high-definition 15.6-inch touch screen.

3. Run/Stop Key

Controls the operating status of the channel output signal.

4. Default

Press this key to restore the instrument to its default settings.

5. Working Mode Switchover Key (Currently Unavailable)

Press this key to switch between DSO and AWG modes.

6. Quick Operation Key

Related to quick operation setting. It is used to customize the quick operation key for a specified function. By default, it's a shortcut key for screen capture.

7.  **Local Key**

Temporarily unavailable to use.

8.  **Multifunction Key**

Its function corresponds with the function key currently selected on the secondary high-definition smart and quick-responsive touch screen. By default, it is used to enable or disable the horizontal setting menu.

9.  **Multifunction Knob**

Its function corresponds with the function key currently selected on the secondary high-definition smart and quick-responsive touch screen. By default, it is used to adjust the horizontal position.

10.  **Multifunction Knob**

Its function corresponds with the function key currently selected on the secondary high-definition smart and quick-responsive touch screen. By default, it is used to adjust the horizontal time base.

11. High-Definition Smart and Quick-responsive Shortcut Menu Display

By default, users can operate the instrument with the functions icons available on the small screen. When you press the tilt adjustment key, you can adjust the tilt of the main display on this screen.

12. Channel Vertical Scale Knob

Adjusts the vertical scale of the channel.

13. Channel On/Off Key

Pressing this key continuously can enable or disable the analog input channel.

14. Channel Vertical Offset Knob

Adjusts the vertical offset of the channel.

15. Analog Channel Input Terminals

Used to connect the probe and input the analog signal.

16. Aux Out/Cal Out

- **Aux Out**

Fast-edge signal output interface. It is used to output the 45 ps fast-edge signal.

- **Cal Out**

Calibration signal output interface. It is used to output the DC signal, PRBS(32) signal, or PAM4 signal.

17. Probe Compensation Signal Output Terminal/Ground Terminal

This terminal outputs the probe compensation signal which helps you match a probe's input capacitance to the oscilloscope channel to which it is connected.

18. ESD Wrist Strap Ground

Used to connect the alligator and the ESD wrist strap ground cord to protect the instrument from static shock.

19. Power Key

Powers on or off the instrument.

20. USB HOST Interface

Supports FAT32 format Flash type USB storage device and the USB-GPIB interface converter.

- **USB storage device:** reads the waveform or sequence files saved in the USB storage device; stores the edited waveform and sequence data into the USB storage device; saves the contents displayed on the screen to the USB storage device in the format of a captured image.
- **USB-GPIB interface converter (standard accessory):** extends the GPIB interface for RIGOL instruments that integrates the USB HOST interface but not the GPIB interface.

21. High-Definition Large Touch Screen with One Button Electronic Tilt

The tilt of the 15.6-inch high-definition large touch screen can be electronically adjusted with one button. Displays the menu label and parameter settings of the current function, system state, prompt messages, and other information.

4.4.2 Rear Panel Overview

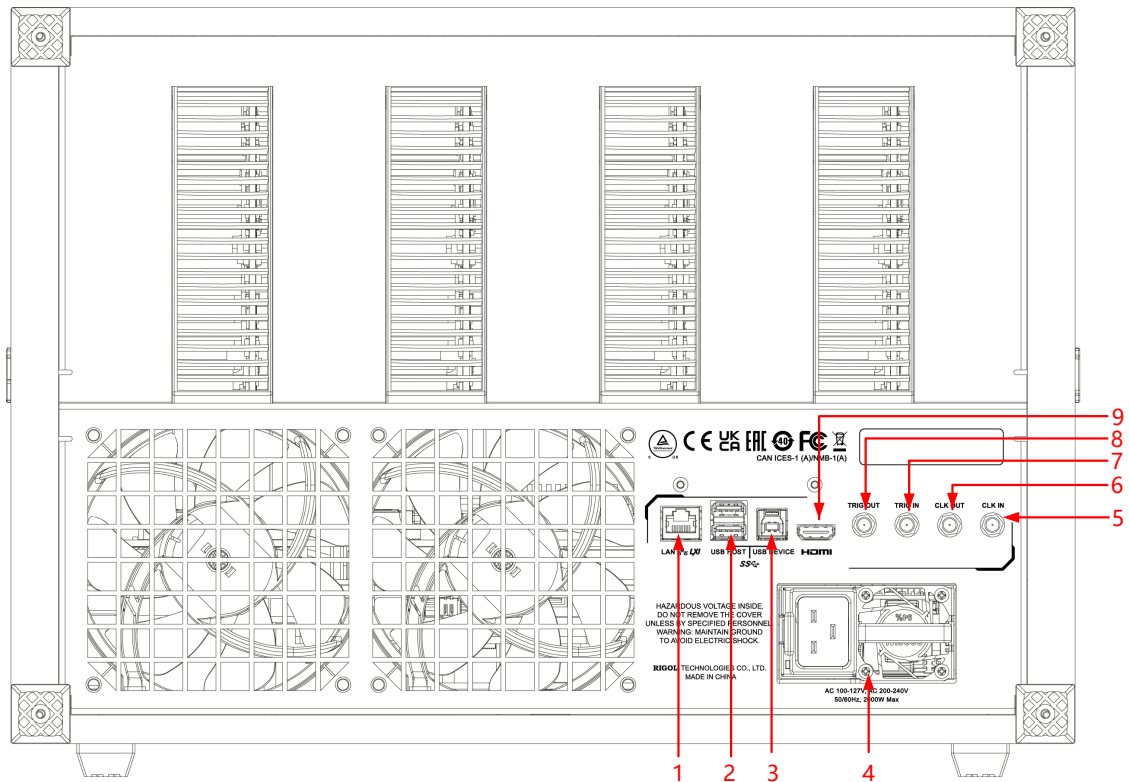

Figure 4.11 DS80000 Rear Panel

1. LAN

Connects the instrument to network via this interface. The instrument is in compliance with the standards specified in *LXI Device Specification 2011*. It can be used to set up a test system with other standard devices. Then you can use the Web Control to send the SCPI commands to control the instrument. When update is available, you can perform online upgrading for the system software of the instrument via the LAN interface.

2. USB HOST Interface

Connects the compatible storage device to the instrument, supporting FAT32 format Flash type USB storage device and the USB-GPIB interface converter.

- **USB storage device:** reads the waveform files or state files saved in the USB storage device; or stores the current instrument states or edited waveform data into the USB storage device; saves the contents displayed on the screen to the USB storage device in the format of a captured image.
- **USB-GPIB interface converter (standard accessory):** extends the GPIB interface for RIGOL instruments that integrates the USB HOST interface but not the GPIB interface.

3. USB DEVICE

Connects the instrument to the PC via this interface. Then you can use the PC software Ultra Scope to send the SCPI commands or use the user-defined programming to control the instrument.

4. Power Module

Includes the AC power cord connector and the fan for power. The AC power specifications supported by the instrument is 100~127 V, 200~240 V, 50/60 Hz. The maximum input power shall not exceed 2000 W. Please insert the power cord provided in the accessories into the AC power connector of the instrument and connect the other end of power cord to the AC power source.

5. CLK IN

Used to input the external reference clock signal.

6. CLK OUT

Used to output the clock signal generated by the internal crystal oscillator inside the instrument.

7. TRIG IN

Used to input the external trigger signal.

8. TRIG OUT

Used to output the trigger signal.

9. HDMI

You can connect the instrument to an external display that has the HDMI interface (e.g. monitor or projector) via this interface to better observe the waveform display clearly. At this time, you can also view the waveforms on the LCD of the instrument.

4.4.3 User Interface

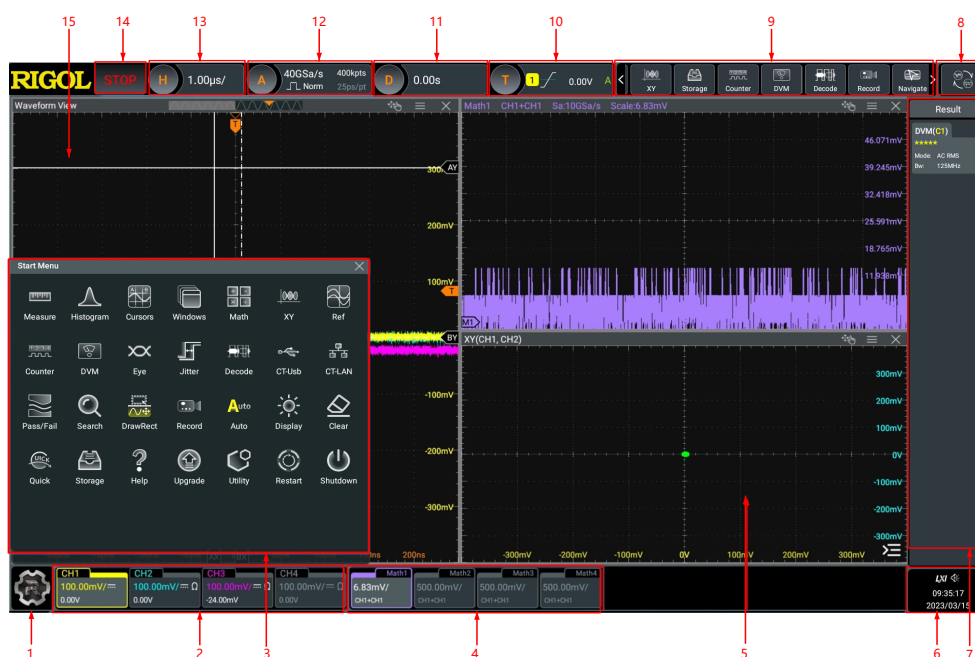

Figure 4.12 DS80000 User Interface

1. Function Navigation Icon

Tap this icon to open the function navigation menu.

2. Channel Status Label

- Displays the on/off status of the channels (CH1~CH4) respectively.
- Displays the coupling mode of the channel.
- Displays the vertical scale of the channel.
- Displays the vertical offset of the channel.

3. Function Navigation Menu

In this menu, tap the specified function icon to enter the desired function menu to configurations.

4. Channel Operation Label





Displays the on/off status of the operation channel (Math1~Math4), its operation type, and vertical scale.

5. Multi-pane Windowing Display Area

If you enable multi-pane windowing display, then multiple windows can be displayed on the screen at one time.

6. Notification Area

Displays the sound icon, USB icon, time, and LAN icon.

- USB storage device icon: When a USB storage device is detected,  will be displayed.
- LAN connection icon: When the LAN interface is successfully connected,  is displayed.
- Sound icon: Click or tap **Utility** > **Setup** > **Beeper** to enable or disable the sound. When on,  will be displayed; when off,  will be displayed.
- Remote control icon: When you control the instrument remotely,  will be displayed.
- Time: displays the system time. For the setting of the system time, refer to descriptions in *Show Time*.

7. Result Display Window

Displays the measurement results and statistics of various functions. Click or tap the  at the lower-right corner of the screen to open or close the statistics result display window.

8. Mode Switchover Icon

Temporarily unavailable.

9. Quick Operation Toolbar

Lists some of the function icons available in the navigation menu, easy for you to select a specified function to perform quick operation.

10. Trigger Information Label

- Displays the trigger information of the system, including the trigger type, trigger level, trigger mode, and etc.
- Click or tap the trigger information label, then the trigger setting window is displayed. You can set the parameters for the trigger.

11. Horizontal Position Label

Displays the current horizontal position. Click or tap this label to enter the horizontal system setting menu.

12. Sample Rate and Memory Depth Label

Displays the current sample rate and memory depth. Click or tap this label to enter the horizontal system setting menu.



13. Horizontal Timebase Label

Displays the current horizontal time base. Click or tap this label to enter the horizontal setting menu.

14. Operating Status

Displays the operating status of the instrument. It includes RUN, STOP, T'D, WAIT, and AUTO.

15. Waveform Display Area

Displays the measurement waveform window for CH1~CH4. Click or tap  at the upper-right corner of the window to close the window. Click or tap  to enter the configuration menu of the specified function.

4.4.4 Secondary 3.5-inch Touch Screen

The 3.5-inch small screen at the right side of the front panel is called secondary screen. The secondary screen separates menus and functions from signals and analysis with a customized function and shortcut menu. You can adjust the inclination of the main display.

Smart Quick-Responsive Shortcut Key Menu Display

The touch-enabled operation of DS80000 series oscilloscope can be operated on both the main and secondary touch screens.



Figure 4.13 Smart Quick-Responsive Shortcut Key Menu Display

1. Multifunction Knob Operation Icon

The icon under the multifunction knob shows the current function of the knob. The icon changes with the selected quick shortcut key. You can use the multifunction knob above the icon to perform the specified function operation.

Let's take an example by illustrating the knob operation in *Figure 4.13*. In the current interface, rotating this knob can adjust the horizontal time base of the oscilloscope; pressing down the knob can switch between the fine adjustment and coarse adjustment for the horizontal time base.

2. Multifunction Knob Operation Icon

The icon under the multifunction knob shows the current function of the knob. The icon changes with the selected quick shortcut key. You can use the multifunction knob above the icon to perform the specified function operation.

Let's take an example by illustrating the knob operation in *Figure 4.13*. In the current interface, pressing down the knob can open or close the horizontal menu.

3. Multifunction Knob Operation Icon

The icon under the multifunction knob shows the current function of the knob. The icon changes with the selected quick shortcut key. You can use the multifunction knob above the icon to perform the specified function operation.

Let's take an example by illustrating the knob operation in *Figure 4.13*. In the current interface, rotating this knob can adjust the horizontal position of the oscilloscope; pressing down the knob can set the horizontal position to zero.

4. SCALE Knob Operation Icon

The icon above the SCALE knob shows function of the knob. The knob below the icon is used to adjust the vertical scale of the four channels. Rotating the knob for the specified channel can adjust the vertical scale of the channel; pressing down the knob can switch between the fine adjustment and coarse adjustment for the vertical scale.

5. OFFSET Knob Operation Icon

The icon above the SCALE knob shows function of the knob. The knob below the icon is used to adjust the vertical offset of the four channels. Rotating the knob for the specified channel can adjust the vertical offset of the channel; pressing down the knob can set the vertical offset to zero.

6. Quick-Responsive Shortcut Key Menu Display

Tap the quick shortcut key on the secondary touch screen to enter the specified function menu or enable the specified function. There are two menu pages and you can tap left and right to switch between the menu pages.

Flip Screen Adjustment Interface

The main display of the DS80000 series oscilloscope can be adjusted with one-button electric tilt. You can tilt the main display on the secondary touch screen. Press the

button  at the upper-right corner of the front panel to enter the tilt adjustment menu interface for the main display, as shown in *Figure 4.14*. Press the

button  again to go back to the quick-responsive shortcut key menu interface.

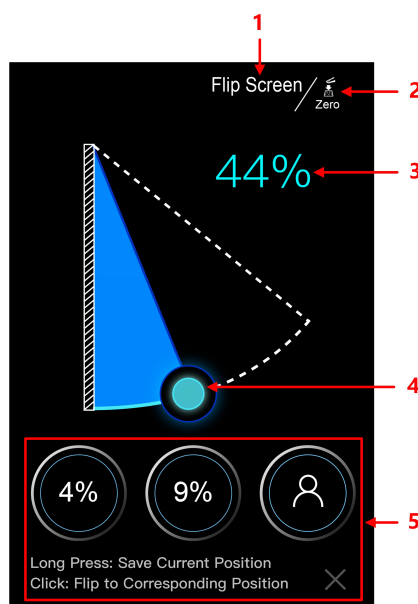



Figure 4.14 Flip Screen Adjustment Interface

1. Current Interface Operation

"Flip Screen" indicates that in the current interface, you can tilt the main display of the oscilloscope.

2. Multifunction Knob Function Icon

Above the icon is the  **Multifunction** knob. The icon shows the function of this knob. Pressing down this knob can reset the tilt of the main display to zero; rotating the knob can adjust the tilt.

3. Flip Screen Angle Percentage

Indicates the tilt percentage of the main display to the max. tilt available for the main display.

4. Tilt Adjustment

Tap to drag the icon to adjust the tilt of the main display.

5. Saved Tilt Angle

This oscilloscope supports users to save three commonly used tilt angle values for the main display. The instructions below show how to adjust the tilt of the main display.

- a. Drag the "Tilt Adjustment" icon to adjust the main display to a required tilt angle.
- b. Long press the "Saved Tilt Angle" icon to save the current tilt angle of the main display. After completing setting a tilt angle for the main display, the tilt percentage value will be shown on the icon.
- c. For future use, you just need to tap the icon with a specified tilt angle on it to make the main display to reach the specified tilt.



CAUTION

During adjusting the tilt of the main display, keep hands clear of the flip screen to avoid being pinched.

4.5 Touch Screen Gestures

The instrument provides a super large capacitive touch screen, which is convenient for users to operate and make configurations. It has strong waveform display capability and excellent user experience. It features great convenience, high flexibility, and great sensitivity. The actions supported by the touch screen controls include tapping, pinching&stretching, dragging, and rectangle drawing.

4.5.1 Tap

Use one finger to tap the symbol or characters on the screen slightly, as shown in *Figure 4.15*. With the Tap gesture, you can perform the following operations:

- Tap the menu displayed on the screen to operate on the menu.
- Tap the function navigation icon at the lower-left corner of the touch screen to enable the function navigation.
- Tap the displayed numeric keypad to set the parameters.
- Tap the virtual keypad to set the label name and the filename.
- Tap the close button at the upper-right corner of the message box to close the prompt window.

- Tap other windows on the touch screen and operate on the windows.



Figure 4.15 Tap Gesture

4.5.2 Pinch&Stretch

Pinch or stretch two points on the screen with two fingers to zoom in or out the waveform. To zoom in the waveform, first pinch the two fingers and then stretch the fingers; to zoom out the waveform, first stretch the two fingers, and then pinch the fingers together, as shown in the figure below. With the pinch&stretch gesture, you can perform the following operation:

- Pinching&stretching in the horizontal direction can adjust the horizontal time base of the waveform.
- Pinching&stretching in the vertical direction can adjust the vertical scale of the waveform.



Figure 4.16 Pinch&Stretch Gesture

4.5.3 Drag

Use one finger to select the object, and then drag the object to a destination place, as shown in [Figure 4.17](#). With the drag gesture, you can perform the following operation:

- Drag the waveform to change its position or scale.
- Drag the window controls to change the position of the window (e.g. numeric keypad).
- Drag the cursor to change the position of the cursor.
- In multi-window display, drag one of the displayed windows to change its position on the screen.

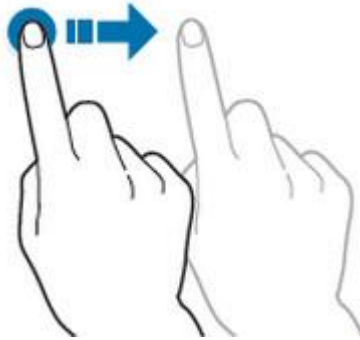



Figure 4.17 Drag Gesture

4.5.4 Rectangle Drawing

Click or tap  > **DrawRect** to switch to the rectangle drawing mode. Drag your finger from upper-left part to lower-right part of the screen to draw a rectangle on the screen, as shown in [Figure 4.18](#). Move your finger away from the screen, and then a menu is displayed on the screen. At this time, you can tap to select "Trigger zone A", "Trigger zone B", "Histogram", "Horizontal zoom in", "Vertical zoom in", "Waveform zoom in", or "Reset". Drag your finger from lower-right part to upper-left part of the screen to draw a rectangle on the screen, as shown in [Figure 4.19](#). Move your finger away from the screen, and then a menu is displayed on the screen. At this time, you can tap to select "Trigger zone A", "Trigger zone B", "Histogram", "Horizontal zoom out", "Vertical zoom out", "Waveform zoom out", or "Reset".

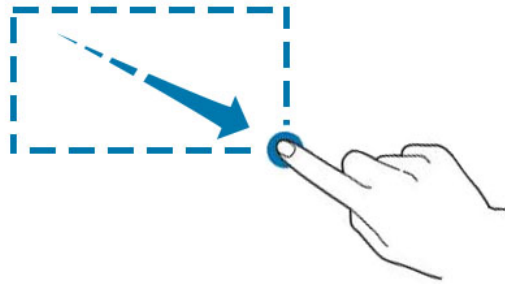

Figure 4.18 Rectangle Drawing Gesture (a)

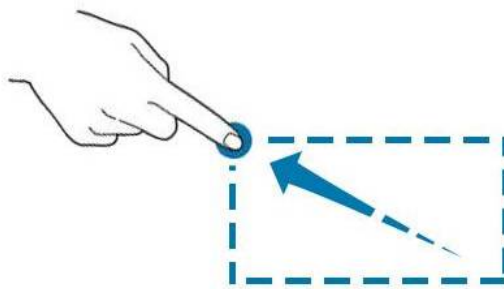



Figure 4.19 Rectangle Drawing Gesture (b)

- Trigger zone A:
 - Draw the region for Trigger zone A;
 - Open Trigger zone A:
 - Open the "Zone Trigger" menu.
- Trigger zone B:
 - Draw the region for Trigger zone B;
 - Open Trigger zone B:
 - Open the "Zone Trigger" menu.
- Histogram:
 - Draw the region for the histogram;
 - Open the "Histogram" menu.
- Horizontal zoom in: expands the waveforms in the horizontal direction.
Horizontal zoom out: compresses the waveforms in the horizontal direction.

- Vertical zoom in: expands the waveforms in the vertical direction.
Vertical zoom out: compresses the waveforms in the vertical direction.
- Waveform zoom in: expands the waveforms both in the horizontal and vertical direction.
Waveform zoom out: compresses the waveforms both in the horizontal and vertical direction.
- Reset: resets the waveforms to its original state where no zoom in or out operation is done to the waveforms.

**TIP**

Click or tap the "DrawRect" icon to switch between the rectangle drawing and waveform operation modes.

Click or tap the "DrawRect" icon, if  is displayed, it indicates that the rectangle drawing mode is enabled. Click or tap the "DrawRect" icon, if  is displayed, it indicates that the waveform operation mode is enabled. By default, the waveform operation mode is enabled.

4.6 Parameter Setting Method

For this instrument, you can use the knob and touch screen to set parameters. The common parameter setting methods are as follows:

- **Method 1:** Some parameters can be adjusted by rotating the knob on the front panel.
- **Method 2:** Click or tap the input field of a specified parameter, then a virtual keypad is displayed. Complete the parameter setting with the keypad.

Input Chinese and English Characters

When naming a label, this instrument supports Chinese/English input method. The following part introduces how to input Chinese and English characters with the Chinese/English input method.

- **Input English Characters**

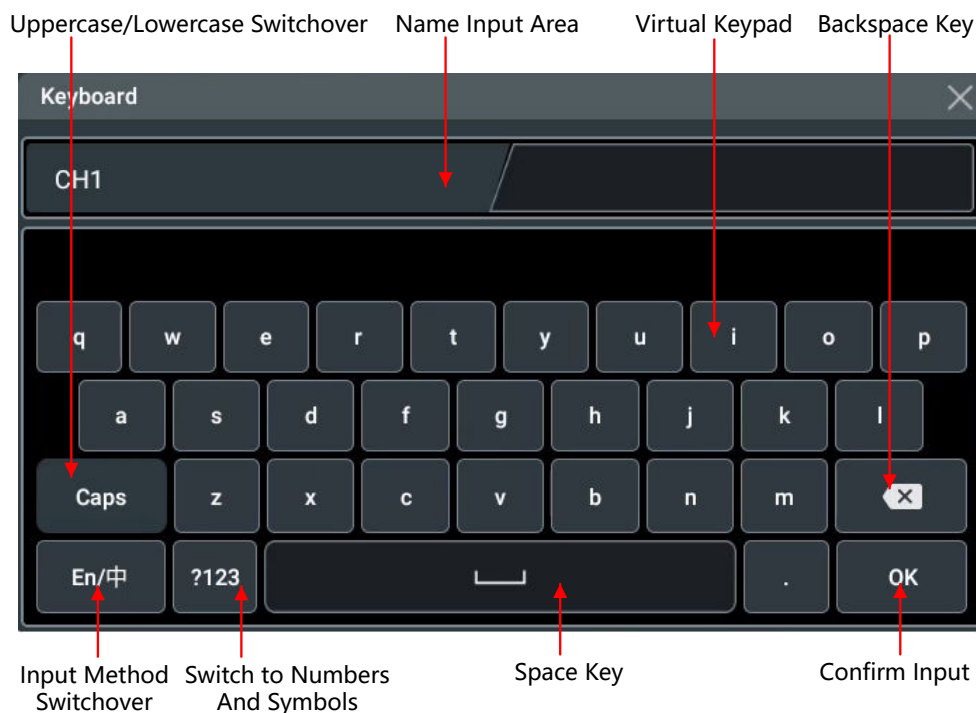

Figure 4.20 English Input Interface

1. Select English input method

First check the input method type. If it shows "En/中", then go to Step 2; if it shows "中/En", click or tap the input method switchover key to switch to "En/中" (English input method).

2. Clear the name input area

If there is no character in the "Name Input Area", please go to the next step. If there are characters in the "Name Input Area", click or tap the Backspace key to delete all the characters from the "Name Input Area" in order.

3. Input the upper-case letter

If you want to input an upper-case letter, first use the Caps key to switch between the upper-case and lower-case mode. If the Caps key is selected, input the upper-case letter with the virtual keypad. If not, first click or tap the Caps key to ensure it is selected, then input the upper-case letter. All the input letters will be displayed in the "Name Input Area".

4. Input the lower-case letter

Refer to the operation specified in the previous step. If the Caps key is not selected, directly input the lower-case letter.

5. Input numbers or symbols

If the letter keypad is displayed, you need to click or tap the numeric switchover key to switch to the numeric keypad, and input numbers or

symbols with the numeric keypad. All the input letters will be displayed in the "Name Input Area".

6. Modify or delete the unwanted characters that have been input

During the name input process, you can modify or delete the unwanted character if necessary. To delete the characters that have been input, click or tap the Backspace key in the virtual keypad to delete the characters. To modify the characters that have been input, delete the unwanted characters first and then input the new characters.

You can directly move the cursor to the character to be modified or deleted, delete the desired character or input the new characters after deleting the unwanted character.

7. Confirm the input

After completing the input operation, click or tap "OK".

- **Input Chinese Characters**



Figure 4.21 Chinese Input Interface

1. Select Chinese input method

First check the input method type. If it shows "中/En", then go to Step 2; if it shows "En/中", click or tap the input method switchover key to switch to "中/En" (Chinese input method).

2. Clear the name input area

If there is no character in the "Name Input Area", please go to the next step. If there are characters in the "Name Input Area", click or tap the Backspace key to delete all the characters from the "Name Input Area" in order.

If there are characters in the "Pinyin Input Area", when you delete characters from the name input area, the characters in the Pinyin input area will be deleted first.

3. Input Chinese characters

Click or tap the characters in the virtual keypad to input Pinyin into the input area, then the characters to be selected will be displayed in the Chinese character selection area. Slide to view more Chinese characters for you to choose. Select the desired Chinese character, and then the selected character will be displayed in the input area.

4. Modify or delete the unwanted characters that have been input

During the name input process, you can modify or delete the unwanted character if necessary. To delete the characters that have been input, click or tap the Backspace key in the virtual keypad to delete the characters. To modify the characters that have been input, delete the unwanted characters first and then input the new characters.

5. Confirm the input

After completing the input operation, click or tap "OK".

Input a String

When naming a file or folder, you need to input a string with the keypad shown in [Figure 4.22](#).

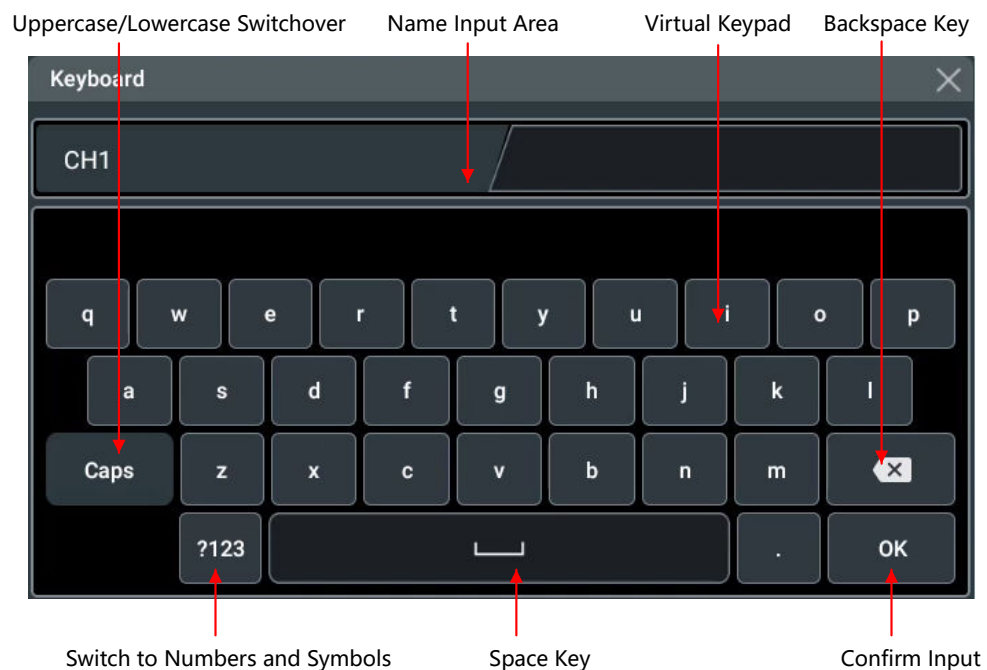

Figure 4.22 String Keypad

1. Clear the name input area

If there is no character in the "Name Input Area", please go to the next step. If there are characters in the "Name Input Area", click or tap the Backspace key to delete all the characters from the "Name Input Area" in order.

2. Input the upper-case letter

If you want to input an upper-case letter, first use the Caps key to switch between the upper-case and lower-case mode. If the Caps key is selected, input the upper-case letter with the virtual keypad. If not, first click or tap the Caps key to ensure it is selected, then input the upper-case letter. All the input letters will be displayed in the "Name Input Area".

3. Input the lower-case letter

Refer to the operation specified in the previous step. If the Caps key is not selected, directly input the lower-case letter.

4. Input numbers or symbols

If the letter keypad is displayed, you need to click or tap the numeric switchover key to switch to the numeric keypad, and input numbers or symbols with the numeric keypad. All the input letters will be displayed in the "Name Input Area".

5. Modify or delete the unwanted characters that have been input

During the name input process, you can modify or delete the unwanted character if necessary. To delete the characters that have been entered, click or tap the Backspace key in the virtual keypad. To modify the characters that have been input, delete the unwanted characters first and then input the new characters.

You can directly move the cursor to the character to be modified or deleted, delete the desired character or input the new characters after deleting the unwanted character.

6. Confirm the input

After completing the input operation, click or tap "OK".

Input a Value

When setting or modifying a parameter, input an appropriate value with the keypad in [Figure 4.23](#).

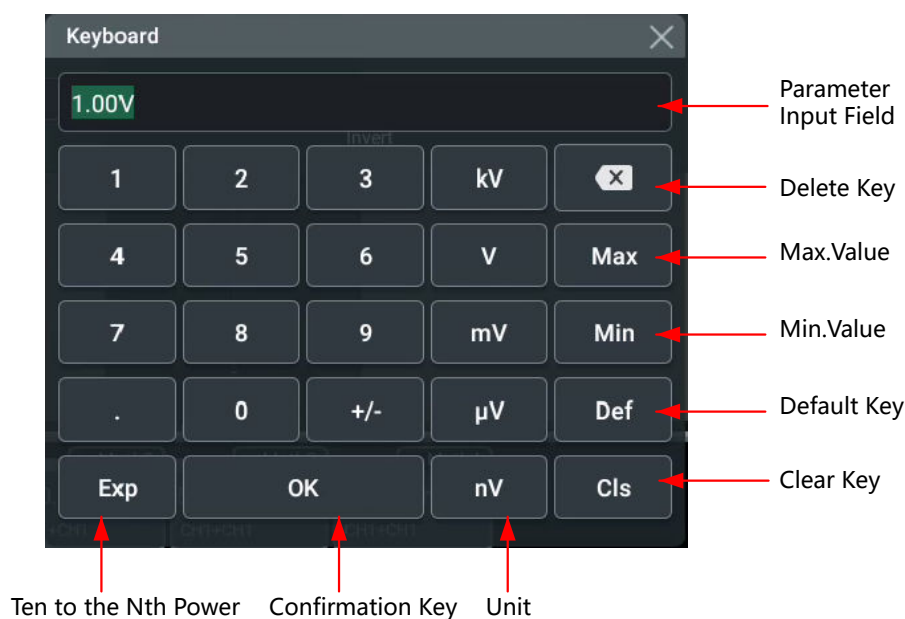



Figure 4.23 Numeric Keypad

Click or tap the value or unit in the numeric keypad to complete the input. After you input all the values and select the desired units, the numeric keypad is turned off automatically. This indicates that you have completed parameter setting. Besides, after you have input the values, you can also click or tap "OK" directly to close the numeric keypad. At this time, the unit of the parameter is the default unit. In the numeric keypad, you can perform the following operations:

- Delete the parameter value that has been input;
- Set the parameter value to a maximum or minimum value;
- Set the parameter to a default value;
- Clear the parameter input field.

4.7 To Use the Built-in Help System

The built-in help file provides information about the functions and menu

introductions of the instrument. Click or tap  > **Help** to enter the help system.

In the help system, you can get its help information by clicking on or tapping the link for the specified chapter.

4.8 To View the Option Information and the Option Installation

This series oscilloscope provides multiple options to fulfill your measurement requirements. If you need any of these options, order them according to the Order No. available in "*Appendix A: Options and Accessories*", and then install the options according to this section. Besides, you can also view the options currently installed on the oscilloscope or activate the newly purchased option.

1. View the installed option

The instrument is installed with the trial versions of the options before leaving factory. When you power on the instrument for the first time, the trial time is about 2,160 minutes. If your instrument has currently installed the options, perform the following operations to view the name of the installed option and other detailed information about the option.

- Click or tap the function navigation icon  at the lower-left corner of the screen, and then select **Utility** to enter the utility function menu.
- Click or tap **Options** to view the options currently installed.

2. Install the option

The option license is a string of fixed characters. The license file should be in specific format, with the filename extension ".lic". After you purchase an option, you will obtain a key (used for obtaining desired the option license code). Then, you can install the option according to the following steps.

a. Obtain an option license

- a. Log in to the **RIGOL** official website (<http://www.rigol.com>), click **SERVICE CENTRE > License Activation** to enter the license activation interface.
- b. In the software license registration interface, input the correct key, serial number (click or tap the function navigation icon  at the lower-left corner of the screen, then select **Utility > About** to obtain the serial number of the instrument), and verification code. Then click **Generate** to obtain the option license. If you need to use the option license file, please click the link to download the file to the root directory of the USB storage device.

b. Install the option

- a. Confirm that the option license file is located in the root directory of the USB storage device, and connect the USB storage device to the oscilloscope properly.
- b. Install the option by sending SCPI commands. For details, refer to *DS80000 Programming Guide*.

- c. After installation, a prompt message "Option activated successfully" is displayed. After the option has been installed, you are recommended to restart the instrument.

**TIP**

- Only 1 option license file of one instrument is allowed to be stored in the same USB storage device, but the USB storage device can store the option license file of several different instruments. You are not allowed to modify the licensed filename.
- During the installation process, you are not allowed to power off the instrument or pull out the USB storage device.
- Sending the SCPI commands (:SYSTEM:OPTion:INSTall <license>) to install options is supported. Installing options by inputting the license code manually is not supported.

5 To Set the Vertical System

DS80000 series provides 4 (CH1~CH4) analog input channels. Each channel is equipped with an independent vertical control system. The setting methods for the vertical systems of the 4 channels are the same. This chapter takes CH1 as an example to introduce the setting method for the vertical system.

Enable the touch screen operation and tap the channel status label at the bottom of the screen. Then the menu shown in the following figure is displayed.

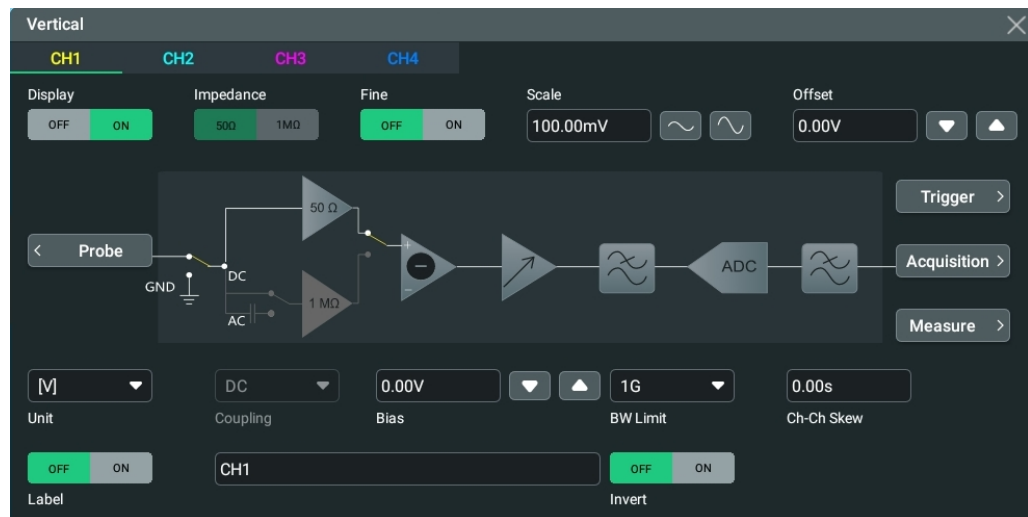



Figure 5.1 Vertical Menu for Channel

5.1 To Enable or Disable the Analog Channel

Enable the Analog Channel

When a signal is connected to CH1, you can enable the channel by the following methods.

- Click or tap the channel status label at the bottom of the screen to enable the channel.
- Press the front-panel key  to enable the channel, and the backlight of this key and the corresponding channel key is illuminated.
- In *To Set the Vertical System*, select the CH1 tab, click or tap **ON** for the **Display** menu item to turn CH1 on.

When the channel is activated (enabled and selected), its channel status label at the bottom of the screen is shown in the figure below.

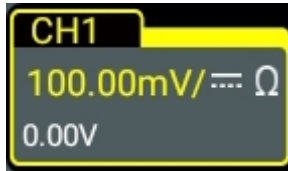

The information displayed in the channel status label is related to the current channel setting (irrelevant with the on/off status of the channel). After the channel is turned on, modify the parameters such as the vertical scale, horizontal time base, trigger mode, and trigger level according to the input signal for easy observation and measurement of the waveform.

If CH1 is enabled but not activated, the channel status label is shown in the following figure.

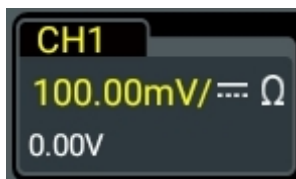

Click/tap the channel status label at the bottom of the screen or press the button



on the front panel to activate the channel CH1.

Disable the Analog Channel

If CH1 is disabled, the channel status label is shown in the figure below.

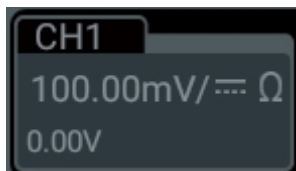

Disable the analog channels by using the following several methods.

- If CH1 has been enabled and activated, you can press  on the front panel to disable it directly. You can also click or tap the channel status label at the bottom of the screen to disable the channel.
- If CH1 has been enabled but not activated, first click or tap the CH1 channel status label at the bottom of the screen, then click or tap it again to disable CH1.
- In *To Set the Vertical System*, you can also disable the channel by setting **Display** to OFF.
- Also, you can tap to slide down the channel label to disable the channel.

5.2 To Adjust the Vertical Scale

Vertical scale indicates the voltage value per grid in the vertical axis of the screen. It is often expressed in V/div. While you adjust the vertical scale, the display amplitude of the waveform would enlarge or reduce. The scale information of the channel status label at the bottom of the screen would change accordingly.

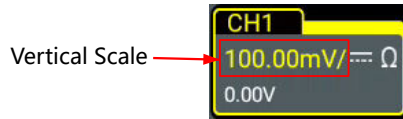

The adjustable range of the vertical scale is related to the currently set probe ratio and input impedance. By default, the probe ratio is 1X and the input impedance is 50 Ω . In this case, the adjustable range of the vertical scale is from 1 mV/div to 1 V/div.

When CH1 is turned on, you can adjust the vertical scale with the following methods:

- Rotate the knob that corresponds to CH1 to adjust the vertical scale (clockwise to reduce the scale and counterclockwise to increase).
- Enable the touch screen function, and then adjust the vertical scale with the pinch & stretch gesture on the touch screen. For details, refer to descriptions in *Pinch&Stretch*.
- In the **Vertical** system menu, click or tap the icon at the right side of the input field of Scale to increase or decrease the scale value. You can also tap the input field to input a specific value with the displayed numeric keypad.



In the **Vertical** system menu, select **ON** or **OFF** to enable or disable the fine adjustment. By default, it is OFF. You can also press down the vertical scale knob on the small screen to enable or disable the fine adjustment.

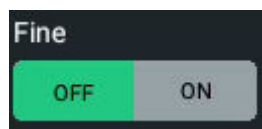

- **Fine adjustment:** Click or tap the icon at the right section of the **Scale** menu to further adjust the vertical scale within a relatively smaller range to improve vertical resolution. To better observe the signal details, enable the fine adjustment function to improve the waveform display amplitude if the following conditions occur: the amplitude of the input waveform is a little bit greater than the full scale of the current scale; using the next scale for adjustment makes the amplitude a little bit lower than expected.

- **Coarse adjustment:** Click or tap the icon at the right section of the **Scale** menu to adjust the vertical scale at 1-2-5 step, i.e. 1 mV/div, 2 mV/div, 5 mV/div, 10 mV/div...1 V/div.

5.3 To Adjust the Vertical Offset

Vertical offset indicates the offset of the signal ground level position of the waveform from the screen center in the vertical direction. Its unit is consistent with the currently selected amplitude unit (refer to "*Amplitude Unit*"). When adjusting the vertical offset, the waveforms of the corresponding channel moves up and down. The vertical offset information (as shown in the following figure) in the channel status label at the bottom of the screen will change accordingly.

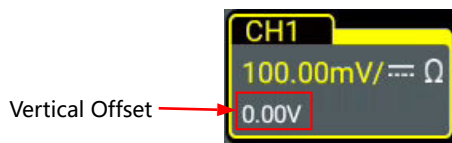

The adjustable range of the vertical offset is related to the current input impedance, probe ratio, and vertical scale.

When CH1 is turned on, you can adjust the vertical offset with the following methods:

- Rotate the  **OFFSET** knob at the right section of the front panel to adjust the vertical offset within the adjustable range. Rotate this knob clockwise to increase the vertical offset, and rotate it counterclockwise to reduce the vertical offset. Pressing down the knob can quickly reset the vertical offset (set the vertical offset to 0).
- Enable the touch screen function, and then adjust the vertical offset with the drag gesture. For details, refer to the "*Drag*" section.
- Click or tap the channel status label at the bottom of the screen. Then the **Vertical** menu is displayed. Click or tap the Up and Down arrow icon at the right side of the input field of **Offset** to increase or decrease the offset value. You can also tap the input field to input a specific value with the displayed numeric keypad.



5.4 Channel Coupling

The undesired signals can be filtered out by setting the coupling mode. The input impedance is fixed to "50 Ω " for this series oscilloscope, and the channel coupling is forced to set to "DC". Therefore, the **Coupling** menu is grayed out and cannot be modified.

5.5 BW Limit

This oscilloscope supports the bandwidth limit function. Setting the bandwidth limit can reduce the noises in the displayed waveforms. For example, the signal under test is a pulse with high frequency oscillation.

- When the bandwidth limit is disabled, the high frequency components of the signal under test can pass the channel.
- If you enable the bandwidth limit and limit it to 500 MHz or 1 GHz, the high frequency components found in the signal under test that are greater than 500 MHz or 1 GHz are attenuated.

Click or tap the channel status label at the bottom of the screen. Then the **Vertical** menu is displayed. Click or tap the drop-down button of the **BW Limit** menu to select the desired bandwidth limit. By default is OFF.

When the bandwidth limit is enabled, the bandwidth limit value is shown in the channel status label at the bottom of the screen, as shown in the figure below.

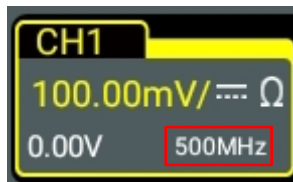

Table 5.1 BW Limit

Input Impedance of the Oscilloscope	Available Bandwidth Limit
50 Ω	500 MHz, 1 GHz, 2 GHz, 3 GHz, 4 GHz, 5 GHz, 6 GHz, 7 GHz, 8 GHz, 9 GHz, 10 GHz, 11 GHz, and 12 GHz



TIP

Bandwidth limit can not only reduce the noise, but also can attenuate or eliminate the high frequency components of the signal.

The bandwidth limit is automatically set to 500 MHz when the vertical scale is smaller than 5 mV.

5.6 Input Impedance

To reduce the circuit load between the oscilloscope and the circuit under test, this oscilloscope provides 50 Ω input impedance. In the **Vertical** system menu, "50Ω" is automatically selected under **Impedance**.

5.7 Waveform Invert

Click or tap the channel status label at the bottom of the screen, and then the **Vertical** menu is displayed. Then click or tap the ON/OFF button for the **Invert** menu item to enable/disable the waveform invert function.

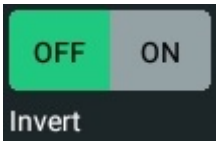

When enabled, the channel label is shown in the following figure.



When the waveform invert is turned off, the waveform is displayed normally; when the waveform invert is turned on, the voltage values of the displayed waveform are inverted, as shown in the figure below. Enabling the waveform invert will also change the result of math function, waveform measurement, etc.

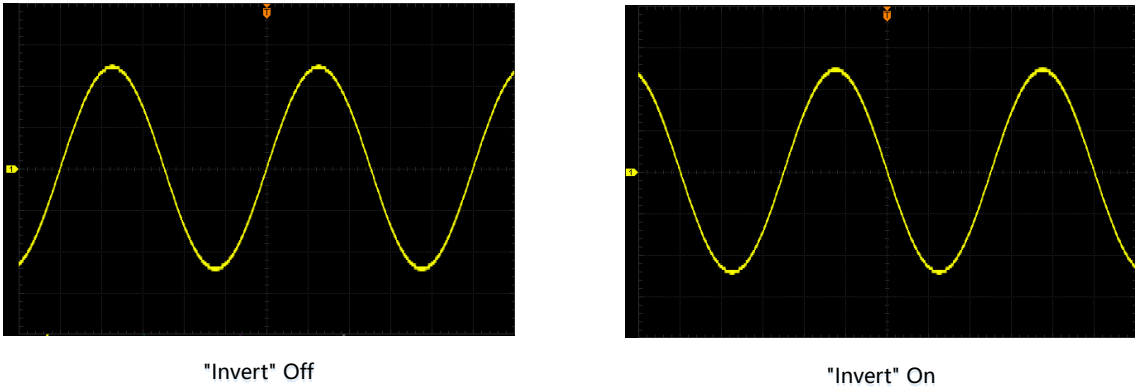

Figure 5.2 Waveform Invert



TIP

When the waveform invert is enabled, the trigger edge or the trigger polarity will change (e.g. Edge trigger, Pulse trigger, or Slope trigger).

5.8 Probe

The analog channel of this oscilloscope not only supports the common passive probe, but also the active probe. It can automatically recognize the currently connected probe type and its probe ratio. For detailed technical information of the probes, please refer to the corresponding Probe User Guide.

Enable the touch screen operation and tap the channel status label at the bottom of the screen. Then the menu **Vertical** is displayed. Then click or tap **Probe** to enter the **Probe** setting menu, as shown in the figure below.

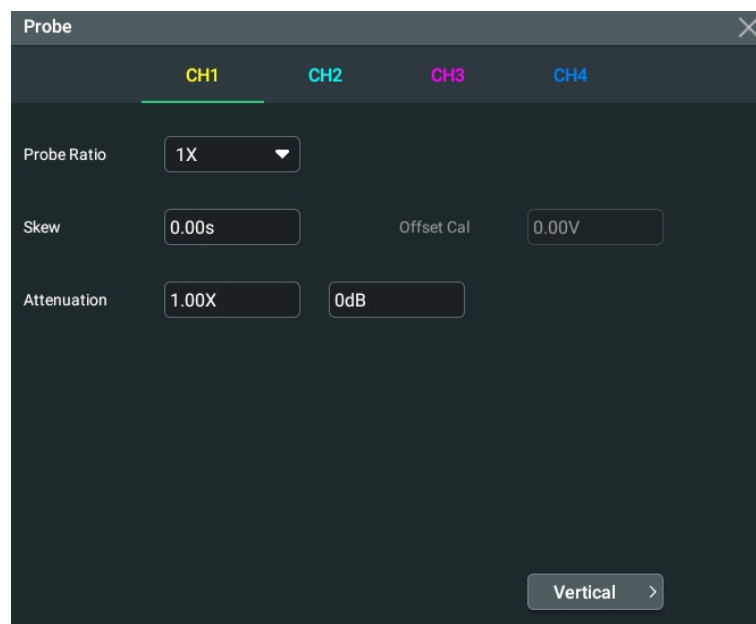

Figure 5.3 Probe Setting Menu

If the instrument works with the RP7000 series, PVA7000 series, or PVA8000 series probe, the probe menu is shown in the figure below. The probe ratio cannot be modified and you need to calibrate the probe. For specific probe models, please refer to *DS80000 Data Sheet*. For detailed technical information of the probes, please refer to the corresponding Probe User Guide.

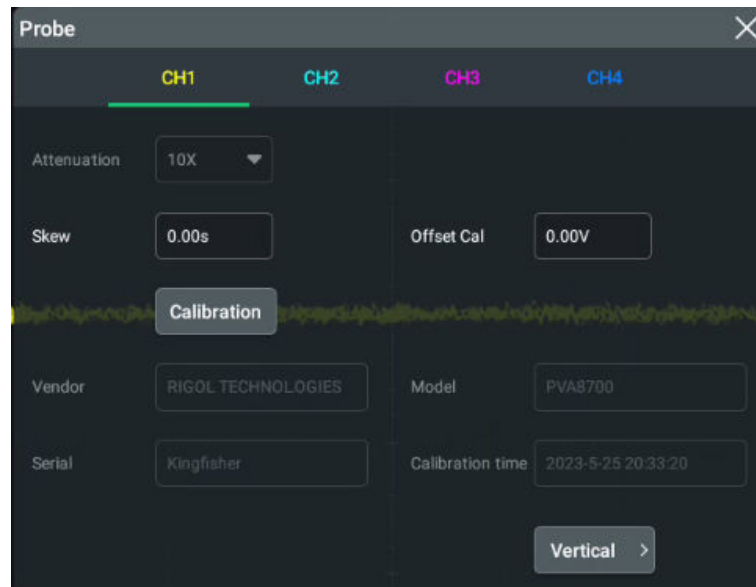

Figure 5.4 RP7000/PVA7000/PVA8000 Probe Setting Menu

Slide to select the channel number (CH1~CH4), or click/tap the channel number to switch to probe setting interface for different channels.

Probe Ratio

The oscilloscope allows you to set the probe attenuation manually. To obtain the correct measurement results, you must set the probe ratio properly. By default, the probe ratio is 1X.

After setting the probe ratio, the relation between the display amplitude of the signal and the actual amplitude of the signal is as follows:

display amplitude of the signal = actual amplitude of the signal x attenuation ratio x probe ratio

TIP

The oscilloscope auto-recognizes certain probes with a fixed attenuation ratio. After being recognized, the probe ratio will also be auto recognized. You do not have to set it manually.

Attenuation

Click or tap the input field of **Attenuation** to set the attenuation ratio for the probe.

After setting the probe ratio, the relation between the display amplitude of the signal and the actual amplitude of the signal is as follows:

display amplitude of the signal = actual amplitude of the signal x attenuation ratio x probe ratio



Skew

Click or tap the input field of **Skew** to set the delay time for the probe. Its range is from -100.00 ns to 100.00 ns. The default value is 0.00 s.

Offset Cal

When working with the RP7000/PVA7000/PVA8000 series probe, you need to click or tap the input field of **Offset Cal** to set the offset calibration of the probe.

Probe Information

In the probe menu, you can view information about the currently connected probe, such as the vendor, model, serial number, and the last calibration time.

Probe Calibration

Click or tap **Calibration** to start the calibration operation. Then the self-calibration window is displayed, as shown in the figure below.

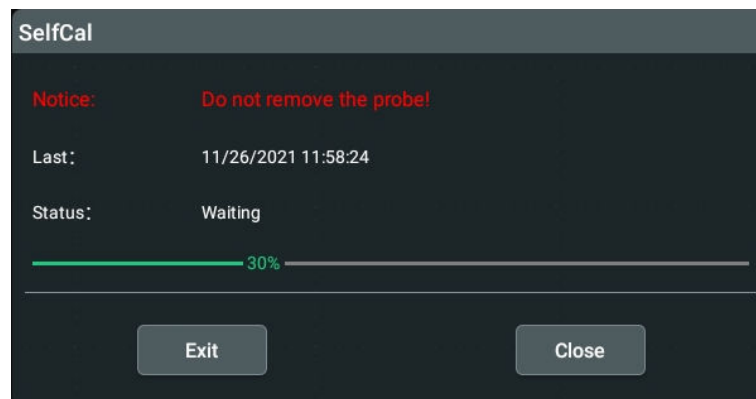

Figure 5.5 SelfCal

Click or tap **Exit** in the self-calibration window to cancel the probe calibration at any time. Click or tap **Close** to close the current self-calibration window. After completing the calibration for the probe, the measurement results can be more accurate.

TIP

If the current channel is disabled, launching the self-calibration will enable the current channel automatically. During the self-calibration, the touch-enabled operation is disabled.

Go Back to the Vertical System Menu

In the **Probe** setting menu, click or tap the **Vertical** menu to go back to the **Vertical** system menu.



5.9 Amplitude Unit

Click or tap the channel status label at the bottom of the screen, and then the **Vertical** menu is displayed. Click or tap the drop-down button of the **Unit** text box to select W, A, V, or U. The default unit is V.

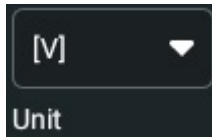

When the amplitude unit is changed, the unit related to the channel will also be changed accordingly.

5.10 Clear

When you use an oscilloscope to make actual measurements, a small offset that arises from the temperature drift of the component or external environment disturbance may occur on the zero-cross voltage of the channel, which will affect the measurement results of the vertical parameters. DS80000 series oscilloscope allows you to set an offset calibration voltage for calibrating the zero point of the corresponding channel, so as to improve the accuracy of the measurement results.

Click or tap the Up and Down arrow icon at the right side of the input field of **Offset Cal** to increase or decrease the bias value. You can also tap the input field to input a specific value with the displayed numeric keypad.

Value Input Field Decrease Increase

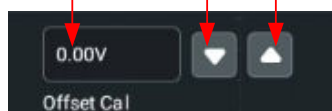

The range of bias is related to the input impedance and the vertical scale.



TIP

If the zero-cross voltage of the channel has a larger amplitude offset that exceeds the adjustable null range, please perform self-calibration for the instrument to ensure the measurement accuracy.

5.11 Channel Delay

When using an oscilloscope for actual measurement, the transmission delay of the probe cable may bring relatively greater errors (zero offset). This series oscilloscope allows you to set a delay time for calibrating the zero offset of the corresponding channel. Zero offset is defined as the offset of the crossing point of the waveform and trigger level line relative to trigger position, as shown in the figure below.

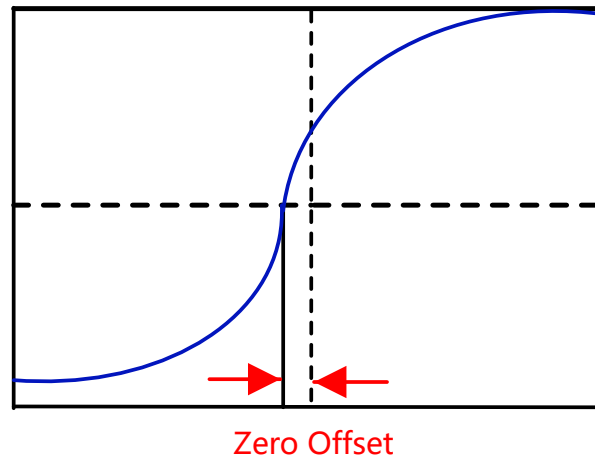

Figure 5.6 Zero Offset

In the "Vertical" menu, click or tap the input field for the **Ch-Ch Skew** item to set the channel-to-channel skew time. The available range is from -100 ns to 100 ns.

5.12 Channel Label

The instrument uses the channel number to mark the corresponding channel by default. For ease of use, you can also set a label for each channel. For example, **CH1**.

Click or tap the channel status label at the bottom of the screen. Then the **Vertical** menu is displayed. Click or tap the ON/OFF button for the **Label** menu item to select whether to display the channel label. You can also click or tap the channel label input field to input a specific name for the channel label with the pop-up numeric keypad.

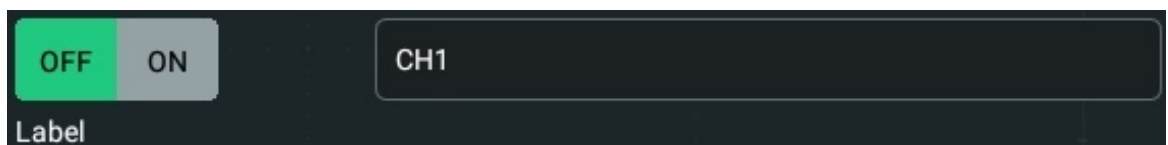

For the methods of using the numeric keypad, refer to descriptions in *Parameter Setting Method*.

6 To Set the Horizontal System

To enter the **Horizontal** system menu, perform any of the following operations:

- Click or tap the channel status label at the bottom of the screen. Then the **Vertical** menu is displayed. Click or tap the **Acquisition** menu to enter the **Horizontal** system menu.
- When the multi-function knob selects the horizontal function, tap the **Horizontal** button on the small screen to enter the **Horizontal** system menu.
- Click or tap the horizontal time base label ("H" icon), acquisition label ("A" icon), or horizontal position label ("D" icon) at the top of the screen to enter the **Horizontal** system menu.

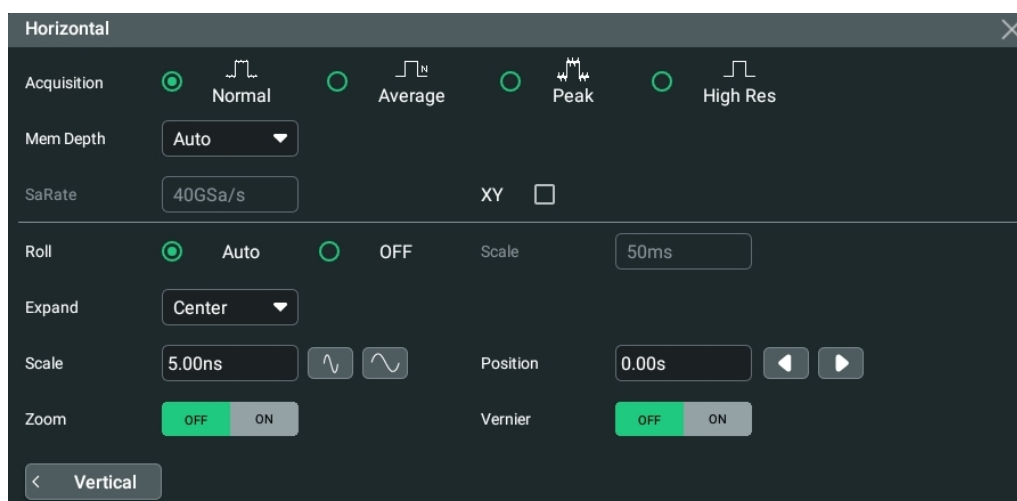
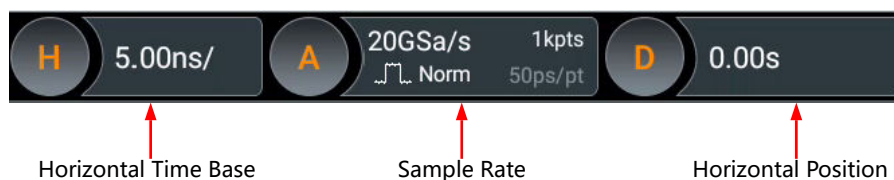

Figure 6.1 Horizontal System Menu

6.1 To Adjust the Horizontal Time Base

Horizontal time base, also called the horizontal scale, refers to the time of each grid in the horizontal direction of the screen. It is usually expressed in s/div. The range of the horizontal time base is from 20.00 ps/div to 1.00 ks/div. By default, it is 5 ns/div.

While you change the horizontal time base, the displayed waveforms of all channels are expanded or compressed (refer to *Horizontal Expansion*) horizontally relative to the current selected horizontal reference baseline. The horizontal time base at the

upper-left corner of the screen will be changed accordingly, as shown in the figure below.



You can adjust the horizontal time base with the following methods.

- In the **Horizontal** system menu, click or tap the icon at the right side of the input field of **Scale** to increase or decrease the horizontal time base. You can also click or tap the input field to input a specific value with the displayed numeric keypad.

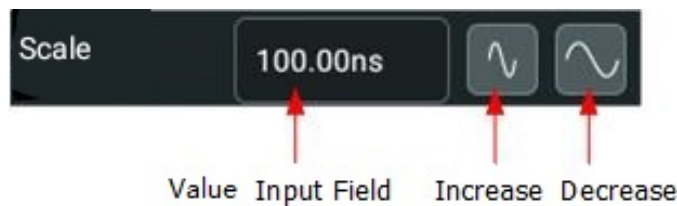

- Enable the touch screen function, and then adjust the horizontal time base with the Pinch&Stretch gesture. For details, refer to *Pinch&Stretch*.

In the **Horizontal** system menu, you can click or tap the ON/OFF tab for the **Vernier** menu to enable or disable the fine adjustment function.

- Coarse adjustment:** Click or tap the icon at the right side of the input field of **Scale** to adjust the horizontal time base of the waveforms of all channels at 1-2-5 step within the adjustable range.
- Fine adjustment:** Click or tap the icon at the right side of the input field of **Scale** to adjust the horizontal time base of the waveforms of all channels at a smaller step within the adjustable range.

6.2 To Adjust the Horizontal Position

Horizontal position, also called trigger position, refers to the trigger point position of the waveforms of all channels in the horizontal direction relative to the screen center. When the waveform trigger point is at the left (right) side of the screen center, the horizontal position is a positive (negative) value.

While you change the horizontal position, the waveform trigger points and the displayed waveforms of all channels are moved left and right. The horizontal position at the top of the screen changes accordingly, as shown in the figure below.



You can adjust the horizontal position with the following methods.

- Enable the touch screen function, and then adjust the horizontal position with the drag gesture. For details, refer to the "*Drag*" section.
- In the "Horizontal" menu, click or tap the icon at the right side of the input field of **Position** to increase or decrease the horizontal position, as shown in the figure below.

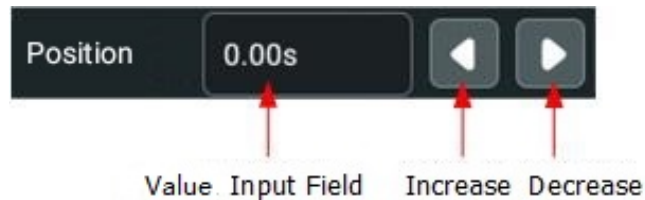

- You can also click or tap the input field of **Position** to input a specific value with the displayed numeric keypad.

6.3 Delayed Sweep

Delayed sweep can be used to enlarge a length of waveform horizontally to view waveform details. In the **Horizontal** system menu, click or tap the ON/OFF tab for the **Zoom** menu to enable or disable the delayed sweep function. When the delayed sweep is enabled, you can set the scale and offset for the delayed sweep.

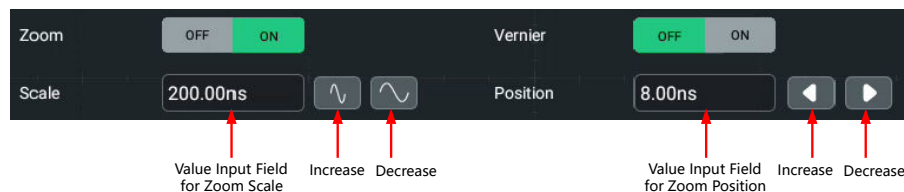

- **Scale:** Click or tap the icon at the right of the **Scale** input field under the **Zoom** menu to increase or decrease the zoom scale. You can also click or tap the value input box to input the specific value directly via the pop-up numeric keypad.
- **Position:** Click or tap the Left/Right arrow icon at the right of the **Position** input field to increase/decrease the position. You can also click or tap the value input box to input the specific value directly via the pop-up numeric keypad.

In delayed sweep mode, the screen is divided into two display areas as shown in the figure below.



Figure 6.2 Delayed Sweep Mode

- Waveform before enlargement:**

The waveform in the area that is not covered by subtransparent blue in the upper part of the screen is the waveform before enlargement. Its horizontal time base (also called main time base) is displayed at the upper-left corner of the screen. You can move the area left and right by adjusting the horizontal position; increase or decrease the size of the area by adjusting the horizontal scale.
- Waveform after enlargement:**

The waveform in the lower part of the screen is the horizontally expanded delayed sweep waveform. Its horizontal time base (also called the time base of the delayed sweep) is displayed on the screen. Compared with the main time base, the time base of the delayed sweep has increased the waveform resolution.

TIP

The time base of the delayed sweep should be smaller than or equal to the main time base.



7 To Set the Sample System

You can set the sample system in *To Set the Horizontal System*.

7.1 Acquisition Mode

The acquisition mode is used to control how to generate waveform points from the sample points. In the **Horizontal** system menu, click or tap the desired acquisition mode for the **Acquisition** menu. The available choices include Normal, Average, Peak, High Res. By default, the acquisition mode is Normal. The acquisition mode will be displayed in the acquisition label at the top of the screen.



Normal

In this mode, the oscilloscope samples the signal at a specified fixed time interval to rebuild the waveform. For most of the waveforms, using this mode can produce the optimal display effects.

Average

In this mode, the oscilloscope averages the waveforms from multiple samples to reduce the random noise of the input signal and improve the vertical resolution. Greater number of averages can lower the noise and increase the vertical resolution; while at the same time, it will slow the response of the displayed waveform to the waveform changes.

When you select "Average" mode, click or tap the input field for the **Averages** menu item to set it by using the pop-up numeric keypad. Its range is from 2 to 65536. Its default value is 2.

TIP

The number of averages must be the Nth power of 2. When it is not in N power-of-2 increments, a prompt message "Truncation average error" is displayed. At this time, a value that is smaller than the one you input and the closest to N power-of-2 increments will be input automatically. For example, if you input 9 with the numeric keypad, the average count will be input 8 automatically.

Peak

In this mode, the oscilloscope acquires the maximum and minimum values of the signal within the sample interval to get the envelope of the signal or the narrow pulse that might be lost. In this mode, signal aliasing can be prevented, but the noise displayed would be larger.



In this mode, the oscilloscope can display all the pulses whose pulse widths are at least the same as the sample period.

High Resolution

This mode uses a kind of ultra-sample technique to average the neighboring points of the sample waveform to reduce the random noise on the input signal and generate much smoother waveforms on the screen. This is generally used when the sample rate of the digital converter is higher than the storage rate of the acquisition memory.

When you select "High Res" mode, click or tap the drop-down button of **bits** to select 9, 10, 12, 14, or 16. Its default value is 9.



TIP

- The averaging modes of the "Average" and "High Res" are different. The former uses "Multi-sample Average" and the latter uses "Single Sample Average".
- In "High Res" mode, the oscilloscope improves the measurement accuracy at the cost of bandwidth. Each time the sampling rate changes, a window displaying the current bandwidth appears in the sample rate menu.

7.2 Sampling Mode

This oscilloscope only supports the real-time sampling mode. In this mode, the oscilloscope produces the waveform display from samples collected during one trigger event. The max. real-time sample rate of this series is 40 GSa/s. The current sample rate is displayed in the acquisition label at the top of the screen.

By default, the operating status label at the left top of the screen is in green, indicating that the instrument is undergoing real-time sampling. Then the **STOP/RUN** icon at the top of the screen is in green. Click or tap the **STOP/RUN** icon to stop sampling, then the **STOP/RUN** icon turns red. The operating status label at the left top of the screen shows STOP in red. At this time, the oscilloscope will maintain its last captured graph. You can still expand or zoom the waveforms by using the horizontal and vertical control menu.

7.3 Sample Rate

Sampling is the process of converting the analog signal into the digital signal at a specified time interval and then restoring them in sequence. The sample rate is the reciprocal of the time interval.

In the **Horizontal** system menu, "SampleRate" shows the current sample rate. The current sample rate is displayed in the acquisition label at the top of the screen, as shown in the figure below.

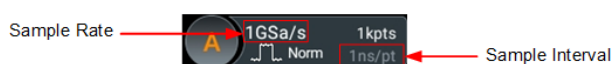

The sample rate of the analog channel is related to the current channel mode. The maximum real-time sample rate in the full-channel mode is 40 GSa/s.

- **Single-channel mode:** only one of the four channels (CH1/CH2/CH3/CH4) is enabled.
- **Full-channel mode:** CH1 and CH2 are considered as a group; CH3 and CH4 are considered as another group. If two channels in either one group or four channels are all enabled, it is called full-channel mode.

The impact of low sample rate on the waveform:

- **Waveform Distortion:** when the sample rate is too low, some waveform details are lost, and the sample waveform displayed is rather different from the actual waveform of the signal.

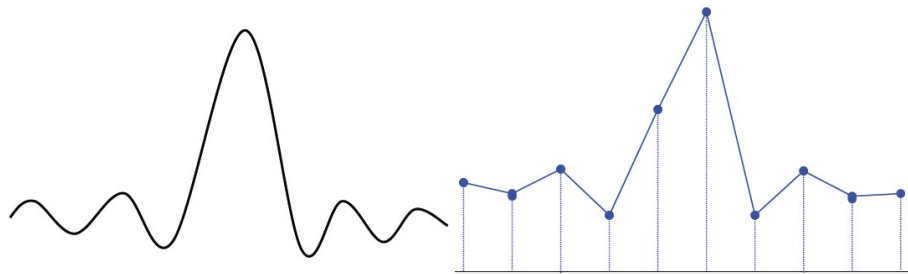

- **Waveform Aliasing:** when the sample rate is twice lower than the actual signal frequency (Nyquist Frequency), the frequency of the waveform rebuilt from the sample data is smaller than the actual signal frequency.

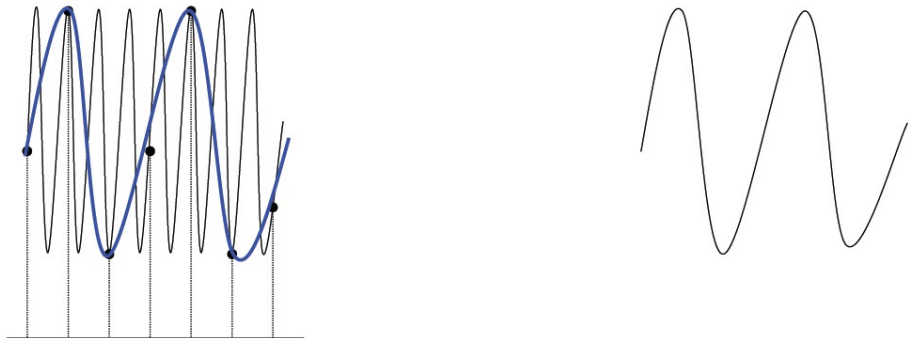

- **Waveform Leakage:** when the sample rate is too low, the waveform rebuilt from the sample data does not reflect all the actual signal information.

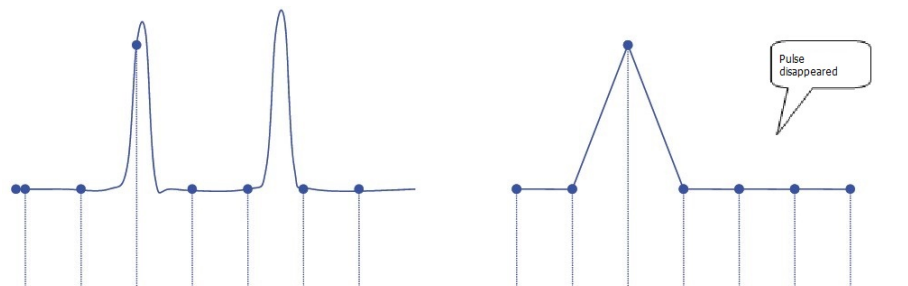

7.4 Memory Depth

Memory depth refers to the number of points of the oscilloscope that can store in one trigger acquisition. It reflects the storage capability of the acquisition storage. This oscilloscope is equipped with a standard memory depth of up to 500 Gpts (4 Gpts for option).

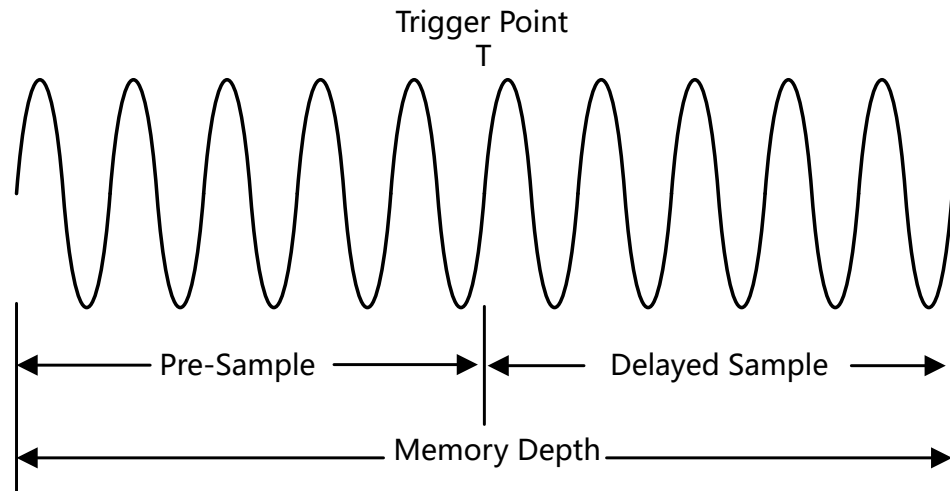

Figure 7.1 Memory Depth

The following equation shows the relations among memory depth, sample rate, and horizontal time base scale:

$$MDepth = SRate \times TScale \times HDivs$$

- **MDepth:** indicates the memory depth. The unit is pts.
- **SRate:** indicates the sample rate. The unit is Sa/s.
- **TScale:** indicates the horizontal time base scale. The unit is s/div.
- **HDivs:** indicates the number of grids in the horizontal direction. The unit is div.

Therefore, under the same horizontal time base scale, a higher memory depth can ensure a higher sample rate.

In the **Horizontal** system menu, click or tap the drop-down button of **Mem Depth** to select the memory depth. By default, the memory depth is 10 Kpts. The memory depth value will be displayed in the sample rate label at the top of the screen.



When one or multiple channels are enabled, the available memory depths are AUTO, 1k, 10k, 100k, 1M, 10M, 100M, 200M, 500M, 1G, 2G (option), and 4G (option).

**TIP**

In "Auto" mode, the oscilloscope selects the memory depth automatically according to the current sample rate.

7.5 Horizontal Expansion

Horizontal expansion indicates the reference position that the screen waveform is referenced to when it is horizontally expanded or compressed in adjusting the horizontal time base. In the **Horizontal** system menu, click or tap the drop-down button of **Expand** to select the horizontal reference baseline. The available choices include Center, Left, Right, Trigger, and User. The default is "Center".

- **Center:** when the horizontal time base is modified, the waveform will be expanded or compressed horizontally relative to the screen center.
- **Left:** when the horizontal time base is modified, the waveform will be expanded or compressed horizontally relative to the leftmost position of the screen.
- **Right:** when the horizontal time base is modified, the waveform will be expanded or compressed horizontally relative to the rightmost position of the screen.
- **Trigger:** when the horizontal time base is modified, the waveform will be expanded or compressed horizontally relative to the trigger point.
- **User:** when the horizontal time base is modified, the waveform displayed will be expanded or compressed horizontally relative to the user-defined reference position.

When you select "User", click or tap the input field of **Expand User**. Input the horizontal expansion reference value with the displayed numeric keypad. Its range is from -500 to 500. Its default value is 0.

7.6 Roll Mode

In Roll mode, the waveforms are updated rolling from right to left on the screen. You do not need to wait until all the complete waveforms are acquired. You can see the acquired data points at any time during its acquisition. In the **Horizontal** system menu, click or tap to select "Auto" or "OFF" for the **Roll** menu.

- **Auto:** enables the Roll mode. When the horizontal time base is set to 50 ms/div or lower than the value, the instrument automatically enters the roll mode.
- **OFF:** disables the Roll mode. In this mode, when the horizontal time base is set to 200 ms/div or lower than this value, the instrument enters slow sweep mode. In this mode, the instrument first acquires the data at the left of the trigger point and then waits for a trigger event. After the trigger occurs, the instrument continues to generate the waveform at the right of the trigger point. When

observing the low-frequency signal in the slow sweep mode, it is recommended that you set "*Channel Coupling*" to "DC".

**TIP**

- If the current delayed sweep is enabled, then when you enable the Roll mode, the delayed sweep is disabled automatically.
- The following functions are not available when the Roll mode is enabled:

To Adjust the Horizontal Position (available when the operating status of the oscilloscope is in STOP state), *Delayed Sweep*, *To Trigger the Oscilloscope*, *Protocol Decoding*, *Pass/Fail Test*, *Waveform Recording and Playing*, *Persistence Time*, *XY Mode*, and *Average*.

7.7 XY Mode

By default, DS80000 series digital oscilloscope uses the YT mode for waveform display window. In this mode, Y-axis indicates the Voltage, X-axis indicates the Time. Besides, it supports XY display window. In this display window, X-axis and Y-axis indicate voltage. The two input channels display from "Voltage-Time" to "Voltage-Voltage".

Open the XY Window

To open the XY window, perform the following operations:

- Click or tap the **Windows** icon in the function navigation menu to enter the **Add Window** interface. In the Diagram menu, click or tap "XY", and then click or tap **Add** to open the XY mode display window.
- Click or tap the **XY** icon at the upper-right part of the screen to open the XY window.

Configure the XY Window

Click or tap  at the upper-right corner of the XY window to enter the XY configuration menu.

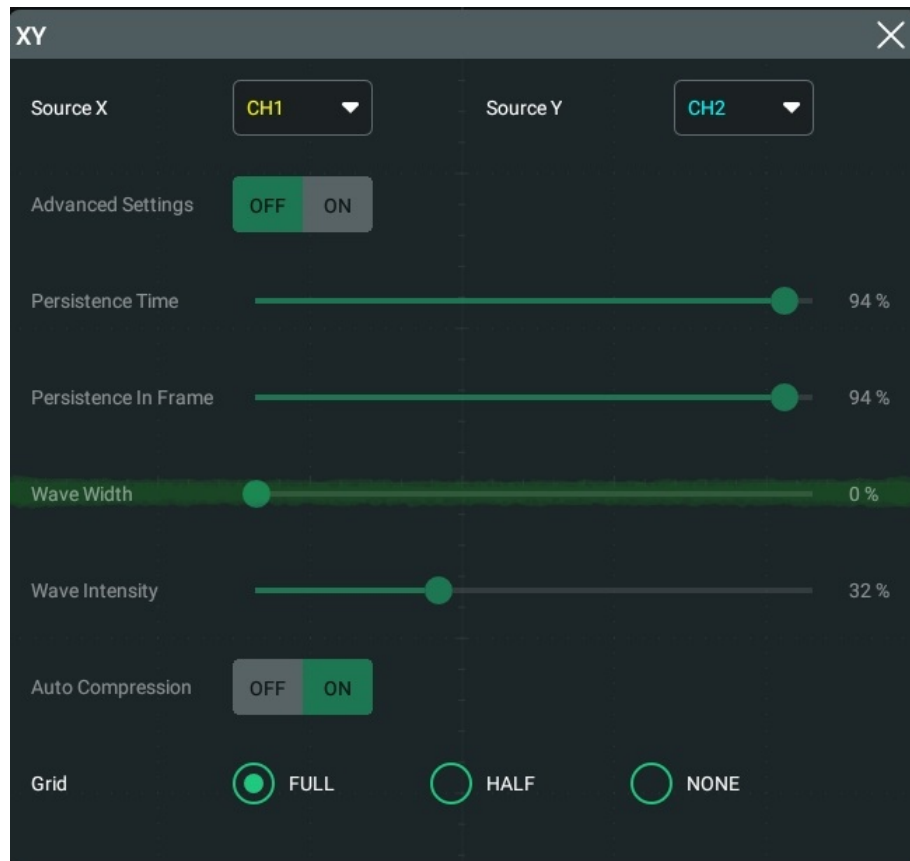

Figure 7.2 XY Setting Menu

- **Source:** Click or tap the drop-down button of "Source X" to select the source channel of the X-axis in the XY window. Click or tap the drop-down button of "Source Y" to select the source channel of the Y-axis in the XY window.

In *Multi-pane Windowing*, you can also configure Source Z. Source Z, as the Z-axis input in the XY display mode, is used to control whether to display the X-Y waveforms in the XY display mode. This function is called "blanking".

- When "None" is selected for "Source Z", the blanking function is disabled, and you can only see the X-Y waveforms.
 - When you select "CH1-CH4" for "Source Z", the blanking function is enabled. The Z-axis input from the external connector determines whether to display the X-Y waveforms. When Z is high (the input level is greater than 0 V), the X-Y waveforms are displayed; when Z is low (the input level is smaller than 0 V), the waveforms are hidden.
- **Grid:** Refer to *To Set the Screen Grid*.



NOTE

Advanced settings are not supported temporarily. The current settings show the most optimal display effects.

Phase Deviation Measurement

In this mode, you can use the Lissajous method to measure the phase deviation of the two input signals whose frequencies are the same. The following figure shows the measurement schematic diagram of phase deviation.

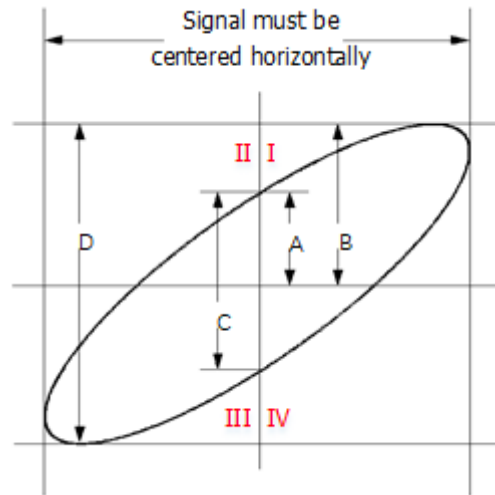

Figure 7.3 Measurement Schematic Diagram of Phase Deviation

According to $\sin\theta = A/B$ or C/D , θ is the phase deviation angle between the two channels. The definitions of A, B, C, and D are shown in the above figure. The phase deviation angle is obtained, that is:

$$\theta = \pm \arcsin(A/B) \text{ or } \pm \arcsin(C/D)$$

If the principal axis of the ellipse is within Quadrant I and III, the phase deviation angle obtained should be within Quadrant I and IV, namely within $(0 \text{ to } \pi/2)$ or $(3\pi/2 \text{ to } 2\pi)$. If the principal axis of the ellipse is within Quadrant II and IV, the phase deviation angle obtained should be within Quadrant II and III, namely within $(\pi/2 \text{ to } \pi)$ or $(\pi \text{ to } 3\pi/2)$.

The XY mode can be used to measure the phase deviation occurred when the signal under test passes through a circuit network. Connect the oscilloscope to the circuit to monitor the input and output signals of the circuit.

8 To Trigger the Oscilloscope

As for trigger, you set certain trigger condition according to the requirement and when a waveform in the waveform stream meets this condition, the oscilloscope captures this waveform as well as the neighboring part, and displays them on the screen. For the digital oscilloscope, it samples waveform continuously no matter whether it is stably triggered, but only stable trigger can be stably displayed. The trigger module ensures that every time base sweep or acquisition starts from the user-defined trigger condition, namely every sweep is synchronous with the acquisition and the waveforms acquired is overlapped so as to display the stable waveforms.

Trigger settings should be based on the features of the input signal. To quickly capture the desired waveform, you need to understand the signal under test. This oscilloscope provides abundant trigger types that help you focus on the desired waveform details.

To enter the **Trigger** menu, perform any of the following operations:

- Click or tap the trigger information label at the top of the screen to enter the trigger setting menu.



- In *To Set the Vertical System*, click or tap the **Trigger** button to enter the trigger setting menu.

8.1 Trigger Source

In the "Trigger" menu, click or tap the drop-down button of **Source** to select the desired source from the drop-down list. The available channels include analog channels (CH1~CH4) and EXT (external trigger).

Analog channel input



Signals input from analog channels (CH1~CH4) can all be used as trigger sources. No matter whether the channel selected is enabled, the channel can work normally.

External Trigger Input

The external trigger source can be used to trigger on Channel 5 while all of the 4 channels are acquiring data. The trigger signal (e.g. external clock or signal of the circuit under test) will be connected to the external trigger source via the external trigger input terminal **[TRIG IN]** connector. You can set the trigger conditions within the range of the trigger level (from -8 V to +8 V).



8.2 Trigger Level

The adjustment of the trigger level is related to the type of the trigger source.

- When the trigger source is CH1~CH4, and when the multifunction knob selects the trigger function, rotate the knob  at the upper-right part of the secondary screen to adjust the trigger level. You can also click or tap the input field of CH1~CH4 to set the trigger level with the pop-up numeric keypad. During the adjustment, a trigger level line (the color of the trigger level line is the same as that of the channel) and a trigger label " " are displayed on the screen, and they move up and down with the variation of the trigger level. When you stopping modifying the trigger level, the trigger level line disappears in about 2 s. The current trigger level is displayed in the the trigger information label at the top of the screen.

In Runt Trigger, Slope Trigger, and Window trigger, you need to set the upper

and lower limits of the trigger level. Rotate the knob  at the upper-right part of the secondary screen to adjust the trigger level. You can also click or tap the input field of CH1~CH4 to set the trigger level with the pop-up numeric keypad.

Two trigger level labels  and  are displayed at the right section of the screen.

- When the trigger source is EXT, rotate the knob  at the upper-right part of the secondary screen to adjust the trigger level. You can also click or tap the input field of CH1~CH4 to set the trigger level with the pop-up numeric keypad. The current trigger level is displayed in the the trigger information label at the top of the screen.

For this trigger source, only the variation of the trigger level value is displayed on the screen during the adjustment of the trigger level, without displaying the trigger level lines on the screen.

To ensure the waveforms to be better triggered, for a trigger with a single level, you can directly click or tap "50%" in the level menu or press down the trigger level knob to make the level move to the middle of the waveform. However, for a trigger (e.g. Slope trigger, Runt trigger, Window trigger, and MIL-STD-1553) with two levels, you need to click or tap "90%" and "10%" in the level menu or press down the trigger level knob to make the level move to within the range of the waveform amplitude.

8.3 Trigger Mode

The following is the schematic diagram of the acquisition memory. To easily understand the trigger event, we classify the acquisition memory into the pre-trigger buffer and post-trigger buffer.

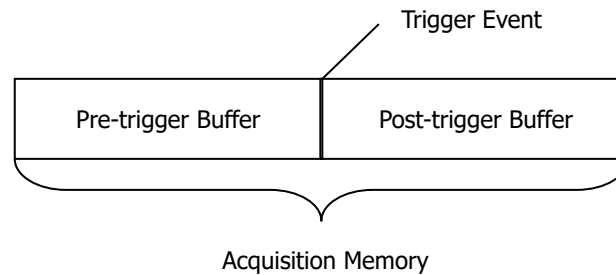



Figure 8.1 Schematic Diagram of the Acquisition Memory

After the system runs, the oscilloscope operates by first filling the pre-trigger buffer. It starts searching for a trigger after the pre-trigger buffer is filled. While searching for the trigger, the data sampled will still be transmitted to the pre-trigger buffer (the new data will continuously overwrite the previous data). When a trigger is found, the pre-trigger buffer contains the data acquired just before the trigger. Then, the oscilloscope will fill the post-trigger buffer and display the data in the acquisition

memory. If the acquisition is activated via  (RUN/STOP), the oscilloscope will repeat this process; if the acquisition is activated via tapping the "Single" icon on the small screen, the oscilloscope will stop after finishing a single acquisition (you can pan and zoom the currently displayed waveform).

DS80000 provides Auto, Normal, and Single trigger modes, and the default is Auto.

Click or tap the trigger information label at the top of the screen or the "Trigger" icon on the small screen to open the "Trigger" menu. Click or tap the sub-items for the **Sweep** menu to quickly switch the current trigger mode. The trigger mode is displayed in the trigger information label at the top of the screen: A (Auto), N (Normal), and S (Single).



- **Auto:** In this trigger mode, if the specified trigger conditions are not found, triggers are forced and acquisitions are made so as to display the waveforms. This trigger mode should be used when the signal level is unknown or the DC should be displayed as well as when forcible trigger is not necessary as the trigger condition always occurs.
- **Normal:** In this trigger mode, triggers and acquisitions only occur when the specified trigger conditions are found. This trigger mode should be used when the signal is with low repetition rate or only the event specified by the trigger setting needs to be sampled as well as when auto trigger should be prevented to acquire stable display.
- **Single:** In this trigger mode, the oscilloscope performs a single trigger and acquisition when the specified trigger conditions are found, and then stops. This trigger mode should be used when you need to perform a single acquisition of

the specified event and analyze the acquisition result (you can pan and zoom the currently displayed waveform, and the subsequent waveform data will not overwrite the current waveform). After a single trigger mode is initiated, the operating status of the oscilloscope is in "STOP" state.

In **Normal** and **Single** trigger modes, pressing **Force** in the trigger menu or the "Force" icon on the small screen can generate a trigger signal forcibly.

8.4 Trigger Coupling

Trigger coupling decides which kind of components will be transmitted to the trigger module. Please distinguish it from "*Channel Coupling*". This function is only valid when the trigger type is Edge and the trigger source is an analog channel.

Click/tap the trigger information label at the top of the screen (as shown in the figure below) or tap the "Trigger" icon on the small screen to open the "Trigger" menu. Click or tap the drop-down button of **Coupling** to select the desired coupling mode (by default, it is DC.) from the drop-down list.



- DC: allows DC and AC components to pass the trigger path.
- AC: blocks the DC components and attenuates the signals.
- LFR: blocks the DC components and rejects the low-frequency components.
- HFR: rejects the high frequency components.

TIP

When "AC" or "LFR" is selected for the coupling mode, no trigger level lines and trigger icons are displayed. When you adjust the trigger level, you can only see the changes of the trigger level values in the trigger information label at the top of the screen.



8.5 Trigger Holdoff

Trigger holdoff can be used to stably trigger on complex repetitive waveforms that have multiple edges or other events between waveform repetitions (such as pulse series). Holdoff time indicates the time that the oscilloscope waits for re-arming the trigger module after generating a correct trigger. The oscilloscope will not trigger even if the trigger condition is met during the holdoff time and will only re-arm the trigger module after the holdoff time expires.

For example, to stably trigger the repetitive pulse series as shown in the figure below, the holdoff time should be set to a value that is greater than t_1 and smaller than t_2 .

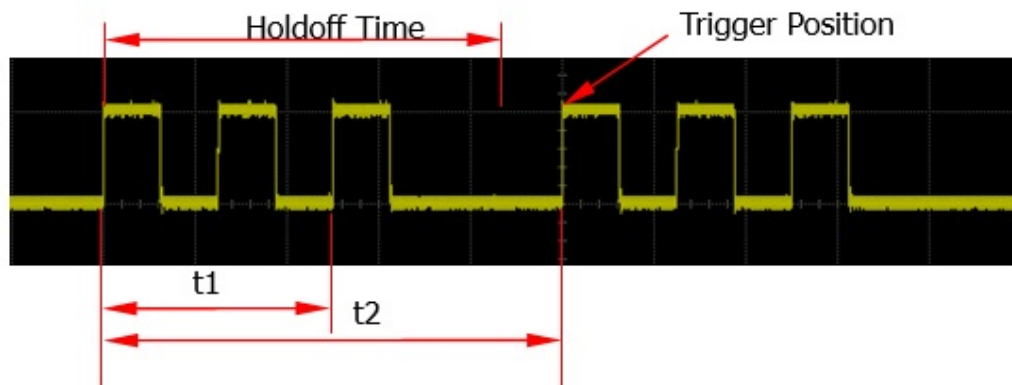

Figure 8.2 Trigger Holdoff

Click or tap the trigger information label (as shown in the figure below) at the top of the screen to open the "Trigger" menu. You can also tap the "Trigger" icon on the small screen to open the trigger menu. Click or tap the input field of **Holdoff** to input the holdoff time (the holdoff to this time when the waveforms are stably triggered; by default, the holdoff time is 8 ns) with the pop-up numeric keypad. The adjustable range of the holdoff time is from 8 ns to 10 s.



8.6 Noise Rejection

Noise rejection can reject the high frequency noise in the signal and reduce the possibility of miss-trigger of the oscilloscope.

Click or tap the trigger information label at the top of the screen or the "Trigger" icon on the small screen to open the "Trigger" menu. Click or tap the ON/OFF tab for the **Noise Reject** menu to enable or disable the noise rejection function.



TIP

This function is only valid when the trigger source is an analog channel or EXT.



8.7 Trigger Type

DS80000 series oscilloscope provides the following trigger types.

8.7.1 Edge Trigger

Triggers on the trigger level of the specified edge of the input signal.

Trigger Type

Click/tap the trigger information label at the top of the screen or tap the **Trigger** icon on the small screen to open the "Trigger" menu. Click or tap the drop-down button of **Type** to select "Edge" from the drop-down list.

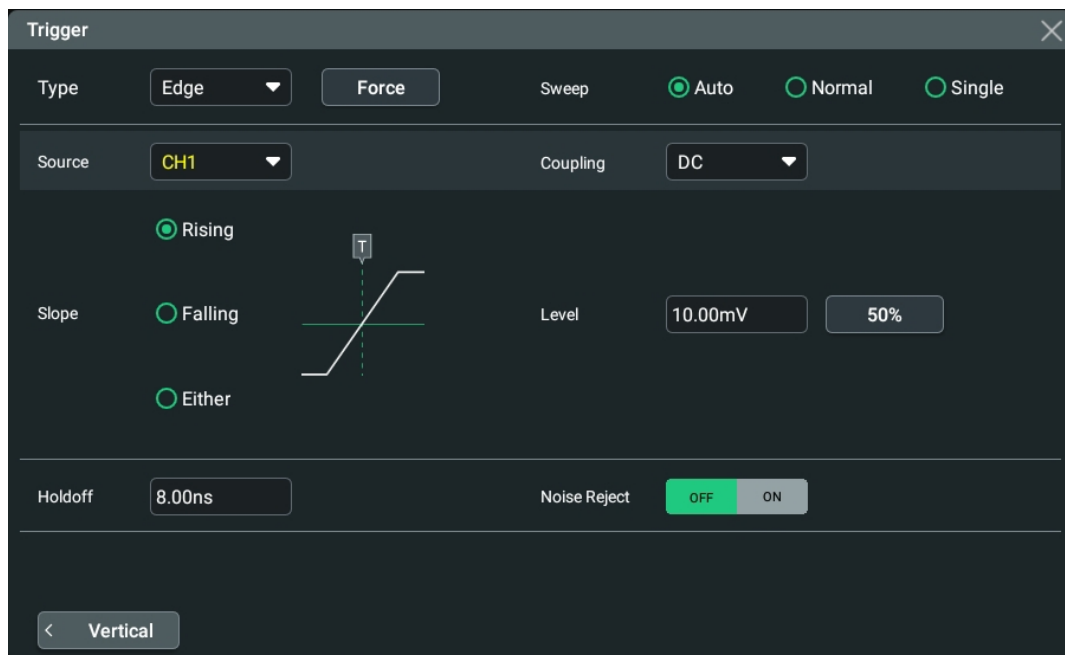

Figure 8.3 Edge Trigger Setting Menu

After selecting the trigger type, and then the current trigger setting information (including trigger type, trigger source, and trigger level) is displayed in the trigger information label at the top of the screen, as shown in the figure below. The information will change based on the trigger settings.



Source Selection

Click or tap the drop-down button of **Source** to select CH1~CH4 or EXT. For details, refer to descriptions in *Trigger Source*. The current trigger source is displayed in the trigger information label at the top of the screen.

Only when we select the channel (that has been input with signals) as the trigger source, can we obtain a stable trigger.

Edge Type

Click or tap the sub-item for the **Slope** menu to select the input signal edge on which the oscilloscope triggers. It will be displayed in the trigger information label.

- Rising: triggers on the rising edge of the input signal when the voltage level meets the specified trigger level.
- Falling: triggers on the falling edge of the input signal when the voltage level meets the specified trigger level.
- Either: triggers on the rising or falling edge of the input signal when the voltage level meets the preset trigger level.

Trigger Mode

In **Sweep** menu, select Auto, Normal, or Single as the trigger mode. For details, refer to descriptions in *Trigger Mode*.

Trigger Parameter Setting

Sets the trigger parameters (trigger coupling, trigger holdoff, and noise rejection) under this trigger type. For details, refer to descriptions in *Trigger Coupling*, *Trigger Holdoff*, and *Noise Rejection*.

Trigger Level

Tap the "Trigger" icon on the secondary screen. When the multifunction knob selects the trigger function, rotate the knob  at the upper-right part of the secondary screen to adjust the trigger level. You can also click or tap the input field of **Level** to set the trigger level with the pop-up numeric keypad. For details, refer to descriptions in *Trigger Level*. The current trigger level is displayed in the trigger information label at the top of the screen.

8.7.2 Pulse Trigger

Triggers on the positive or negative pulse with a specified width. In this mode, the oscilloscope will trigger when the pulse width of the input signal satisfies the specified pulse width condition.

In this oscilloscope, positive pulse width is defined as the time difference between the two crossing points of the trigger level and positive pulse; negative pulse width is defined as the time difference between the two crossing points of the trigger level and negative pulse, as shown in the figure below.

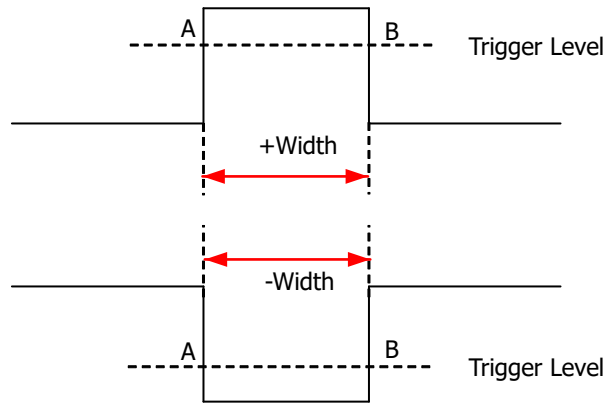

Figure 8.4 Positive Pulse Width/Negative Pulse Width

Trigger Type

Click or tap the drop-down button of **Type** to select "Pulse" from the drop-down list. Then set the parameters for Pulse trigger.

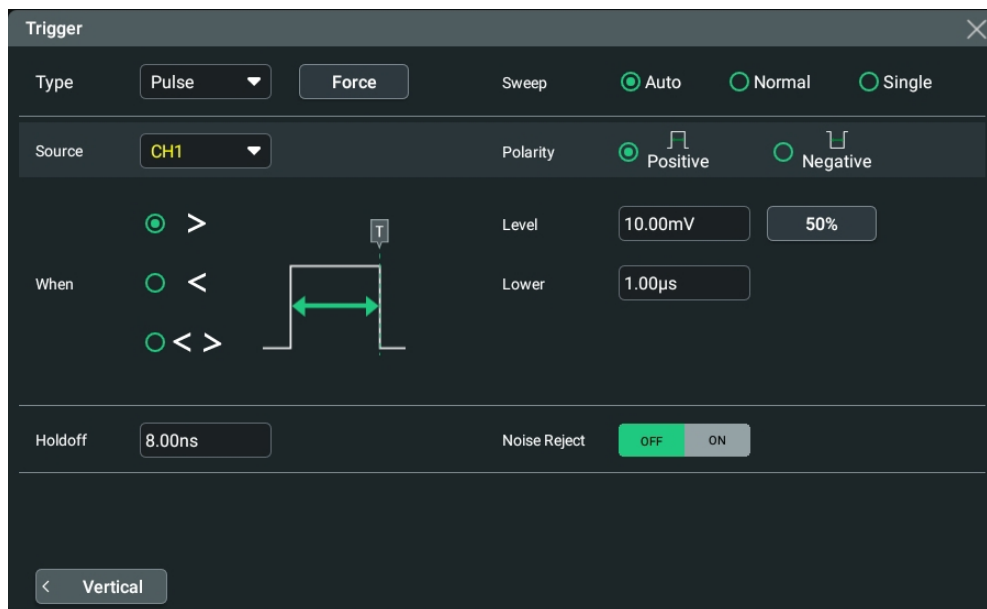

Figure 8.5 Pulse Trigger Setting Menu

After selecting the trigger type, and then the current trigger setting information (including trigger type, trigger source, and trigger level) is displayed in the trigger label at the top of the screen, as shown in the figure below. The information will change based on the trigger settings.





Source Selection

Click or tap the drop-down button of **Source** to select CH1~CH4. For details, refer to descriptions in *Trigger Source*. The current trigger source is displayed in the trigger information label at the top of the screen.

Only when we select the channel (that has been input with signals) as the trigger source, can we obtain a stable trigger.

Polarity

Selects the desired polarity under the **Polarity** menu. The polarities available are positive polarity () and negative polarity ()

Trigger Condition

Sets the trigger condition in the **When** menu.

- When you select "Positive" for polarity, ">" for trigger condition, the oscilloscope triggers when the positive pulse width of the input signal is greater than the specified pulse width.
- When you select "Positive" for polarity, "<" for trigger condition, the oscilloscope triggers when the positive pulse width of the input signal is smaller than the specified pulse width.
- When you select "Positive" for polarity, "< >" for trigger condition, the oscilloscope triggers when the positive pulse width of the input signal is greater than the specified lower limit of pulse width and smaller than the specified upper limit of pulse width.
- When you select "Negative" for polarity, ">" for trigger condition, the oscilloscope triggers when the negative pulse width of the input signal is greater than the specified pulse width.
- When you select "Negative" for polarity, "<" for trigger condition, the oscilloscope triggers when the negative pulse width of the input signal is smaller than the specified pulse width.
- When you select "Negative" for polarity, "< >" for trigger condition, the oscilloscope triggers when the negative pulse width of the input signal is greater than the specified lower limit of pulse width and smaller than the specified upper limit of pulse width.

Pulse Width Setting

- Under the **When** menu, when ">" or "<" is set to trigger conditions, click or tap the input field of **Lower** or **Upper** to set the lower limit value or the upper limit value with the pop-up numeric keypad. The pulse range available is from 100 ps to 10 s.

- Under the **When** menu, when "< >" is set to trigger conditions, click or tap the input field of **Upper** and **Lower** respectively to set the lower limit value and the upper limit value with the pop-up numeric keypad. The lower limit of the pulse width must be smaller than the upper limit.

Trigger Mode

In **Sweep** menu, select Auto, Normal, or Single as the trigger mode. For details, refer to descriptions in *Trigger Mode*.

Trigger Parameter Setting

Sets the trigger parameters (trigger holdoff and noise rejection) under this trigger type. For details, refer to descriptions in *Trigger Holdoff* and *Noise Rejection*.

Trigger Level

Tap the "Trigger" icon on the secondary screen. When the multifunction knob selects the trigger function, rotate the knob  at the upper-right part of the secondary screen to adjust the trigger level. You can also click or tap the input field of **Level** to set the trigger level with the pop-up numeric keypad. For details, refer to descriptions in *Trigger Level*. The current trigger level is displayed in the trigger information label at the top of the screen.

8.7.3 Slope Trigger

In Slope trigger, the oscilloscope triggers on the positive or negative slope of the specified time. This trigger mode is applicable to ramp and triangle waveforms.

In this oscilloscope, positive slope time is defined as the time difference between the two crossing points of trigger level line A and B with the rising edge; negative slope time is defined as the time difference between the two crossing points of trigger level line A and B with the falling edge, as shown in the figure below.

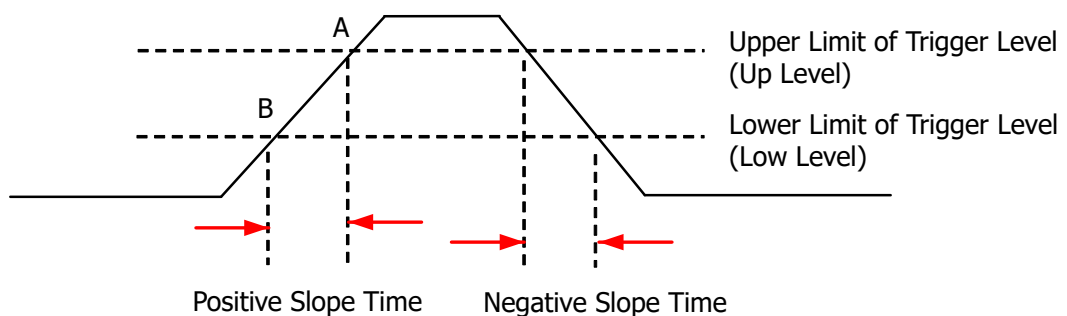

Figure 8.6 Positive Slope Time/Negative Slope Time

Trigger Type

Click or tap the drop-down button of **Type** to select "Slope" from the drop-down list. Then set the parameters for Slope trigger.

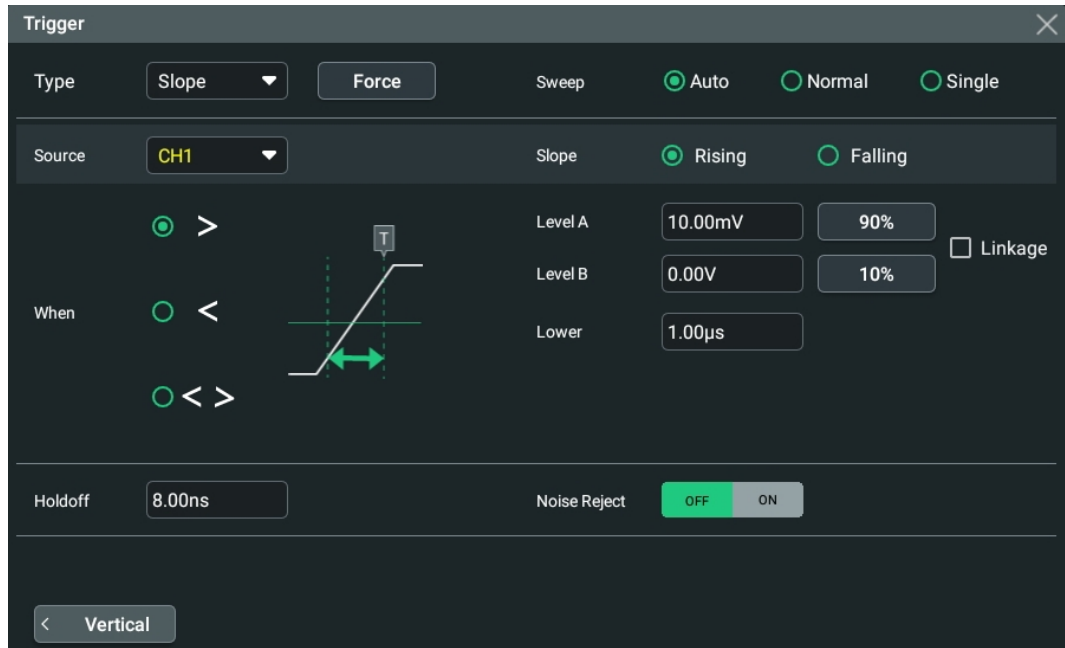

Figure 8.7 Slope Trigger Setting Menu

After selecting the trigger type, and then the current trigger setting information (including trigger type, trigger source, and trigger level) is displayed in the trigger information label at the top of the screen, as shown in the figure below. The information will change based on the trigger settings.



Source Selection

Click or tap the drop-down button of **Source** to select CH1~CH4. For details, refer to descriptions in *Trigger Source*. The current trigger source is displayed in the trigger information label at the top of the screen.

Only when we select the channel (that has been input with signals) as the trigger source, can we obtain a stable trigger.

Edge Type

Select the input signal edge (under the **Slope** menu) on which the oscilloscope triggers.

- Rising: triggers on the rising edge of the input signal.
- Falling: triggers on the falling edge of the input signal.

Trigger Condition

Sets the trigger condition in the **When** menu.

- When you select "Rising" for the edge type, ">" for trigger condition, the oscilloscope triggers when the positive slope time of the input signal is greater than the specified time.
- When you select "Rising" for the edge type, "<" for trigger condition, the oscilloscope triggers when the positive slope time of the input signal is smaller than the specified time.
- When you select "Rising" for the edge type, "< >" for trigger condition, the oscilloscope triggers when the positive slope time of the input signal is greater than the specified lower limit time and smaller than the specified upper limit time.
- When you select "Falling" for the edge type, ">" for trigger condition, the oscilloscope triggers when the negative slope time of the input signal is greater than the specified time.
- When you select "Falling" for the edge type, "<" for trigger condition, the oscilloscope triggers when the negative slope time of the input signal is smaller than the specified time.
- When you select "Falling" for the edge type, "< >" for trigger condition, the oscilloscope triggers when the negative slope time of the input signal is greater than the specified lower limit time and smaller than the specified upper limit time.

Slope Time Setting

- Under the **When** menu, when ">" or "<" is set to trigger conditions, click or tap the input field of **Lower** or **Upper** to set the lower limit value or the upper limit value with the pop-up numeric keypad. The available range of the slope time is from 100 ps to 10 s.
- Under the **When** menu, when "< >" is set to trigger conditions, click or tap the input field of **Upper** and **Lower** respectively to set the lower limit value and the upper limit value with the pop-up numeric keypad.

The lower slope time limit must be smaller than the upper slope time limit.

Trigger Mode

In **Sweep** menu, select Auto, Normal, or Single as the trigger mode. For details, refer to descriptions in *Trigger Mode*.

Trigger Parameter Setting

Sets the trigger parameters (trigger holdoff and noise rejection) under this trigger type. For details, refer to descriptions in *Trigger Holdoff* and *Noise Rejection*.

Level Selection and Setting

After the trigger condition setting is completed, you need to adjust the trigger level to correctly trigger the signal and obtain a stable waveform.

- Level A: only adjusts the upper limit of the trigger level, and the lower limit of the trigger level remains unchanged.
- Level B: only adjusts the lower limit of the trigger level, and the upper limit of the trigger level remains unchanged.

Click or tap the input field of **Level A** and **Level B** to set the value with the pop-up numeric keypad. For details, refer to descriptions in *Trigger Level*. The current trigger level is displayed in the trigger information label at the top of the screen.

Check the checkbox of **Linkage** to link Level A and Level B.

8.7.4 Video Trigger

The video signal can include image information and timing information, which adopts different standards and formats. DS80000 series can trigger on the standard video signal field or line of NTSC (National Television Standards Committee), PAL (Phase Alternating Line), or SECAM (Sequential Couleur A Memoire).

Trigger Type

Click or tap the drop-down button of **Type** to select "Video" from the drop-down list. Then set the parameters for Video trigger.

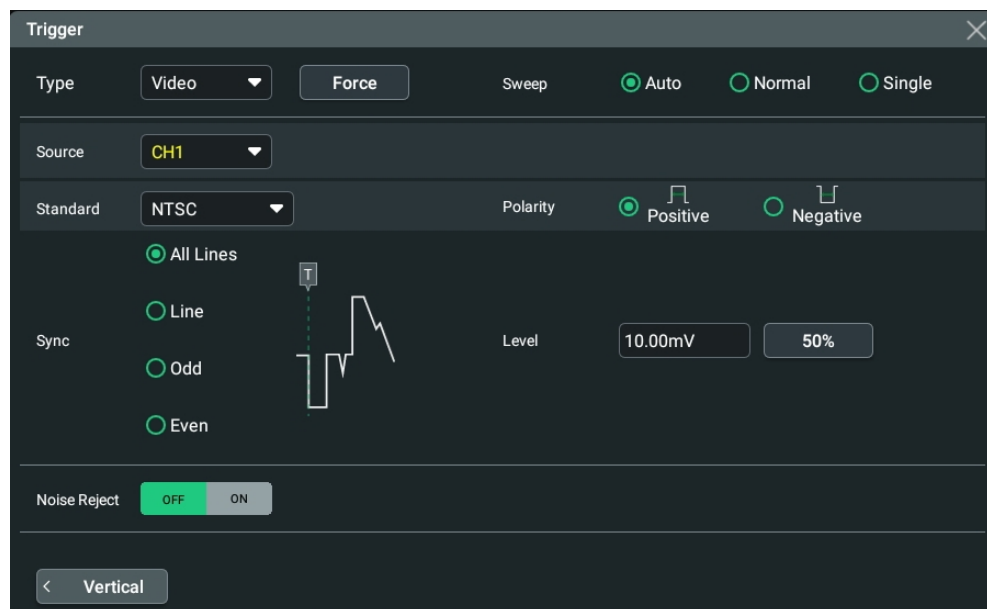
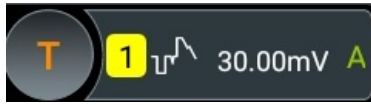

Figure 8.8 Video Trigger Setting Menu

After selecting the trigger type, and then the current trigger setting information (including trigger type, trigger source, and trigger level) is displayed in the trigger

information label at the top of the screen, as shown in the figure below. The information will change based on the trigger settings.





Source Selection

Click or tap the drop-down button of **Source** to select CH1~CH4. For details, refer to descriptions in *Trigger Source*. The current trigger source is displayed in the trigger information label at the top of the screen.

Only when we select the channel (that has been input with signals) as the trigger source, can we obtain a stable trigger.

Video Polarity

Selects the desired polarity under the **Polarity** menu. The polarities available are positive polarity () and negative polarity ()

Video Standard

Click or tap the drop-down button of **Standard** to select the desired video standard.

Table 8.1 Video Standard

Video Standard	Frame Frequency (Frame)	Scan Type	TV Scan Line
NTSC	30	Interlaced Scan	525
PAL/SECAM	25	Interlaced Scan	625
480p/60Hz	60	Progressive Scan	525
576p/50Hz	50	Progressive Scan	625
720p/60Hz	60	Progressive Scan	750
720p/50Hz	50	Progressive Scan	750
720p/30Hz	30	Progressive Scan	750
720p/25Hz	25	Progressive Scan	750
720p/24Hz	24	Progressive Scan	750
1080p/60Hz	60	Progressive Scan	1125
1080p/50Hz	50	Progressive Scan	1125
1080p/30Hz	30	Progressive Scan	1125
1080p/25Hz	25	Progressive Scan	1125
1080p/24Hz	24	Progressive Scan	1125
1080i/60Hz	60	Interlaced Scan	1125
1080i/50Hz	50	Interlaced Scan	1125

Sync

Selects the desired sync type from the drop-down list of the **Sync** menu.

- All Lines: triggers on the first line found.
- Line: triggers on the specified line.

When this sync type is selected, you can specify a line number. Click or tap the input field of **Line** to set the line number by using the pop-up numeric keypad. The range of the line number is related to the currently selected video standards. The range is from 1 to 525 (NTSC), 1 to 625 (PAL/SECAM), 1 to 525 (480p), 1 to 625 (576p), 1 to 750 (720p), or 1 to 1125 (1080p/ 1080i).

- Odd: triggers on the rising edge of the first ramp pulse in the odd field. It is only available when the video standard is set to "NTSC" or "PAL/SECAM".
- Even: triggers on the rising edge of the first ramp pulse in the even field. It is only available when the video standard is set to "NTSC" or "PAL/SECAM".

Trigger Mode

In **Sweep** menu, select Auto, Normal, or Single as the trigger mode. For details, refer to descriptions in *Trigger Mode*.

Trigger Parameter Setting

Sets the trigger parameter (noise rejection) under this trigger type. For details, refer to descriptions in "*Noise Reject*".

Trigger Level

Tap the "Trigger" icon on the secondary screen. When the multifunction knob selects the trigger function, rotate the knob  at the upper-right part of the secondary screen to adjust the trigger level. You can also click or tap the input field of **Level** to set the trigger level with the pop-up numeric keypad. For details, refer to descriptions in *Trigger Level*. The current trigger level is displayed in the trigger information label at the top of the screen.

TIP

- For a better observation of the waveform details in the video signal, you can set a larger memory depth first.
- In the trigger debugging process of video signals, the frequency in different part of the signal can be reflected by a different brightness, as RIGOL's digital oscilloscope provides the intensity graded color display function. Experienced users can quickly judge the signal quality and discover abnormalities during the debugging process.



8.7.5 Pattern Trigger

Identifies a trigger condition by searching for a specified pattern. This pattern is a logical "AND" combination of channels. Each channel can be set to H (high), L (low), or X (don't care). A rising or falling edge (you can only specify a single edge) can be specified for one channel included in the pattern. When an edge is specified, the oscilloscope will trigger at the edge specified if the pattern set for the other channels are true (namely the actual pattern of the channel is the same as the preset pattern). If no edge is specified, the oscilloscope will trigger on the last edge that makes the pattern true. If all the channels in the pattern are set to "X", the oscilloscope will not trigger.

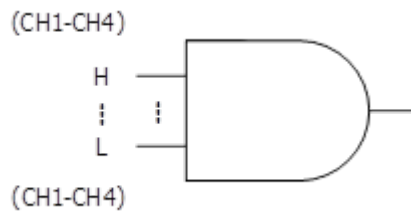

Figure 8.9 Pattern Trigger

Trigger Type

Click or tap the drop-down button of **Type** to select "Pattern" from the drop-down list. Then set the parameters for the Pattern trigger.

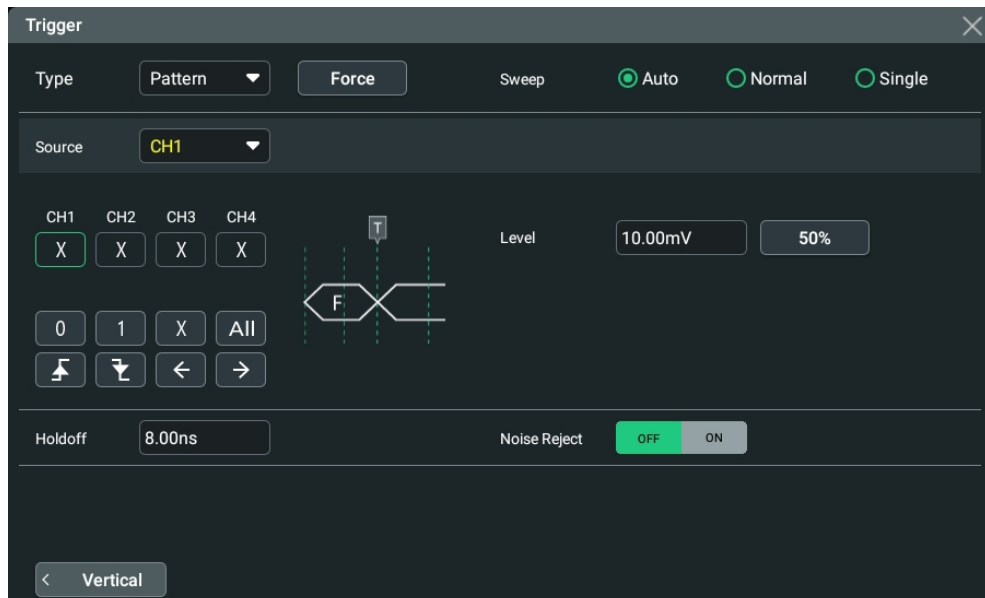
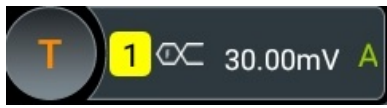

Figure 8.10 Pattern Trigger Setting Menu

After selecting the trigger type, and then the current trigger setting information (including trigger type, trigger source, and trigger level) is displayed in the trigger

information label at the top of the screen, as shown in the figure below. The information will change based on the trigger settings.





Source Selection

Click or tap the drop-down button of **Source** to select CH1~CH4. For details, refer to descriptions in *Trigger Source*. The current trigger source is displayed in the trigger information label at the top of the screen.

Only when we select the channel (that has been input with signals) as the trigger source, can we obtain a stable trigger.

Pattern Setting

The following five patterns are available:

- 1: sets the pattern of the channel selected to "1", that is, the voltage level is higher than the trigger level of the channel.
- 0: sets the pattern of the channel selected to "0", that is, the voltage level is lower than the trigger level of the channel.
- X: sets the pattern of the channel selected to "X", that is, this channel is not used as a part of the pattern. When all channels in the pattern are set to "X", the oscilloscope will not trigger.
- : sets the pattern to the rising edge of the channel selected.
- : sets the pattern to the falling edge of the channel selected.

The Left/Right arrow key indicates moving left/right to switch the channel pattern.

"All" indicates all bits. Select a pattern for a channel, then click or tap **All**. The patterns of all the other channels will be set to the currently selected pattern. The pattern setting is shown in the figure below:



Only one edge (rising or falling edge) can be specified in the pattern. If one edge item is currently defined and then another edge item is defined in another channel in the pattern, then a prompt message "Invalid input" is displayed.

Trigger Mode

In **Sweep** menu, select Auto, Normal, or Single as the trigger mode. For details, refer to descriptions in *Trigger Mode*.

Trigger Parameter Setting

Sets the trigger parameters (trigger holdoff and noise rejection) under this trigger type. For details, refer to descriptions in *Trigger Holdoff* and *Noise Rejection*.

Trigger Level

Tap the "Trigger" icon on the secondary screen. When the multifunction knob selects the trigger function, rotate the knob  at the upper-right part of the secondary screen to adjust the trigger level. You can also click or tap the input field of **Level** to set the trigger level with the pop-up numeric keypad. For details, refer to descriptions in *Trigger Level*. The current trigger level is displayed in the trigger information label at the top of the screen.

8.7.6 Duration Trigger

In duration trigger, the instrument identifies a trigger condition by searching for the duration of a specified pattern. This pattern is a logical "AND" combination of the channels. Each channel can be set to 1 (high), 0 (low), or X (don't care). The instrument triggers when the duration (ΔT) of this pattern meets the preset time, as shown in the figure below.

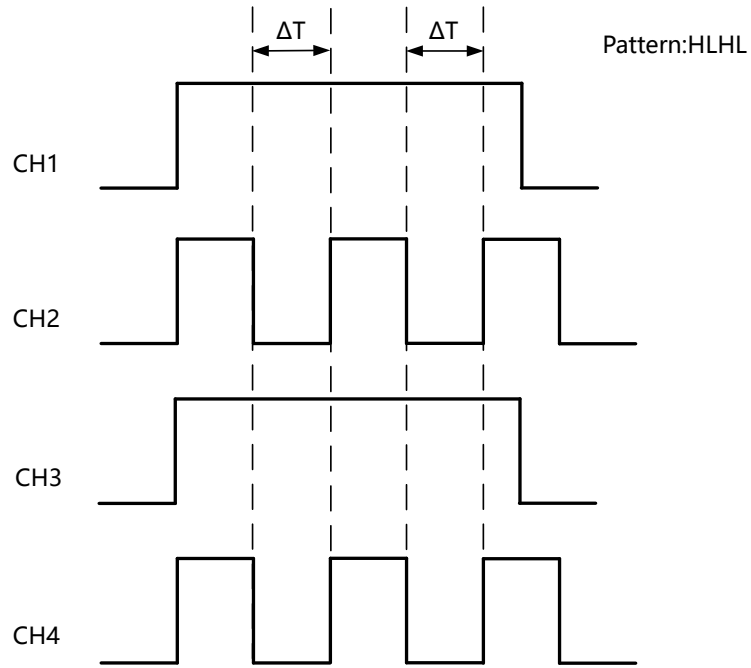

Figure 8.11 Duration Trigger

Trigger Type:

Click or tap the drop-down button of **Type** to select "Duration" from the drop-down list. After selecting the trigger type, then the current trigger setting information (including trigger type, trigger source, and trigger level) is displayed in the trigger information label at the top of the screen, as shown in the figure below. The information will change based on the trigger settings.

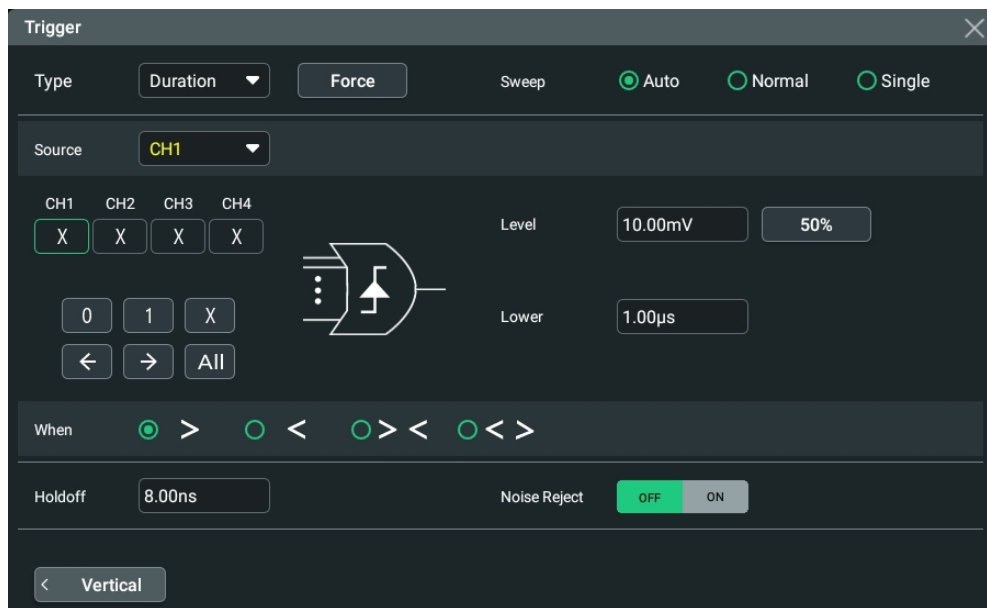

Figure 8.12 Duration Trigger Setting Menu

After selecting the trigger type, and then the current trigger setting information (including trigger type, trigger source, and trigger level) is displayed in the trigger information label at the top of the screen, as shown in the figure below. The information will change based on the trigger settings.



Source Selection

Click or tap the drop-down button of **Source** to select CH1~CH4. For details, refer to descriptions in *Trigger Source*. The current trigger source is displayed in the trigger information label at the top of the screen.

Only when we select the channel (that has been input with signals) as the trigger source, can we obtain a stable trigger.

Pattern Setting

The following three patterns are available:

- 1: sets the pattern of the channel selected to "1", that is, the voltage level is higher than the trigger level of the channel.
- 0: sets the pattern of the channel selected to "0", that is, the voltage level is lower than the trigger level of the channel.
- X: sets the pattern of the channel selected to "X", that is, this channel is not used as a part of the pattern. When all channels in the pattern are set to "X", the oscilloscope will not trigger.

The Left/Right arrow key indicates moving left/right to switch the channel pattern. "All" indicates all bits. Select a pattern for a channel, then click or tap **All**. The patterns of all the other channels will be set to the currently selected pattern.

Trigger Condition

Sets the trigger condition in the **When** menu.

- >: triggers when the duration of the pattern is greater than the preset time. Click or tap the input field of **Lower** to set the lower limit of the duration of the pattern with the pop-up numeric keypad. Its range is from 100 ps to 10 s.
- <: triggers when the duration of the pattern is smaller than the preset time. Click or tap the input field of **Upper** to set the upper limit of the duration of the pattern. Its range is from 100 ps to 10 s.
- < >: triggers when the duration of the pattern is smaller than the upper limit of the preset time and greater than the lower limit of the preset time. Click or tap the input field of **Upper** to set the upper limit of the duration of the pattern, and the range is from 101 ps to 10 s. Click or tap the input field of **Lower** to set the

lower limit of the duration of the pattern, and the range is from 100 ps to 9.9 s. The lower time limit must be smaller than the upper time limit.

- > <: triggers when the duration of the pattern is greater than the upper limit of the preset time or smaller than the lower limit of the preset time. Click or tap the input field of **Upper** to set the upper limit of the duration of the pattern, and the range is from 100 ps to 10 s. Click or tap the input field of **Lower** to set the lower limit of the duration of the pattern, and the range is from 100 ps to 9.9 s. The lower time limit must be smaller than the upper time limit.

Trigger Mode

In **Sweep** menu, select Auto, Normal, or Single as the trigger mode. For details, refer to descriptions in *Trigger Mode*.

Trigger Parameter Setting

Sets the trigger parameters (trigger holdoff and noise rejection) under this trigger type. For details, refer to descriptions in *Trigger Holdoff* and *Noise Rejection*.

Trigger Level

Tap the "Trigger" icon on the secondary screen. When the multifunction knob selects the trigger function, rotate the knob  at the upper-right part of the secondary screen to adjust the trigger level. You can also click or tap the input field of **Level** to set the trigger level with the pop-up numeric keypad. For details, refer to descriptions in *Trigger Level*. The current trigger level is displayed in the trigger information label at the top of the screen.

8.7.7 Timeout Trigger

In Timeout trigger, the instrument triggers when the time interval (ΔT) (the time from when the rising edge (or falling edge) of the input signal passes through the trigger level to the time from when the neighboring falling edge (or rising edge) passes through the trigger level) is greater than the preset timeout value, as shown in *Figure 8.13*.

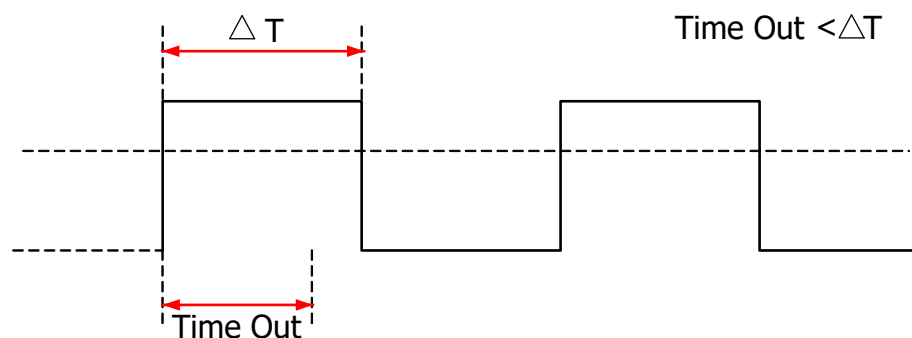

Figure 8.13 Timeout Trigger

Trigger Type

Click or tap the trigger information label at the top of the screen, and then click or tap the drop-down button of **Type** to select "Timeout" from the drop-down list. Then set the parameters for the Timeout trigger in [Figure 8.14](#).

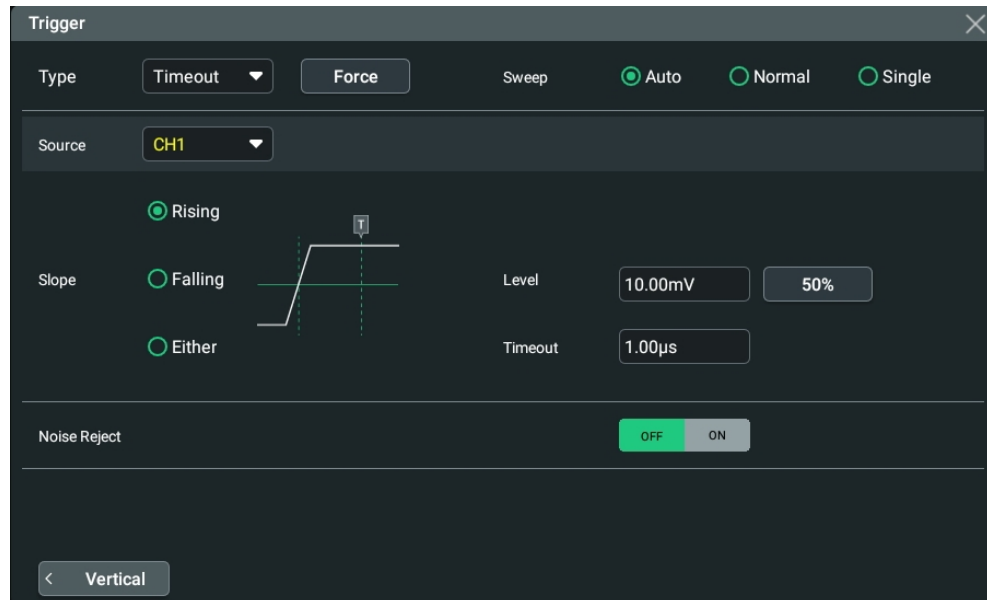
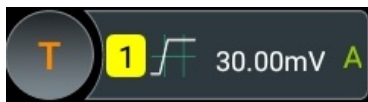

Figure 8.14 Timeout Trigger Menu

At this time, the current trigger setting information (including trigger type, trigger source, and trigger level) is displayed at the top of the screen, as shown in the figure below. The information will change based on the trigger settings.



Source Selection

Click or tap the drop-down button of **Source** to select CH1~CH4. For details, refer to descriptions in [Trigger Source](#). The current trigger source is displayed in the trigger information label at the top of the screen.

Only when we select the channel (that has been input with signals) as the trigger source, can we obtain a stable trigger.

Edge Type

Click or tap the edge type (under **Slope**) from which the input signal passes through the trigger level.

- Rising: starts timing when the rising edge of the input signal passes through the trigger level.

- Falling: starts timing when the falling edge of the input signal passes through the trigger level.
- Either: starts timing when either edge of the input signal passes through the trigger level.

Timeout Value

Timeout value represents the maximum time that the signal remains idle before the signal passes through the trigger level. Click or tap the input field of **Timeout**, and then use the pop-up numeric keypad to set the timeout value of Timeout trigger. The available range is from 16 ns to 10 s.

Trigger Mode

In **Sweep** menu, select Auto, Normal, or Single as the trigger mode. For details, refer to descriptions in *Trigger Mode*.

Trigger Parameter Setting

Sets the trigger parameter (noise rejection) under this trigger type. For details, refer to descriptions in *Noise Reject*.

Trigger Level

Tap the "Trigger" icon on the secondary screen. When the multifunction knob selects the trigger function, rotate the knob  at the upper-right part of the secondary screen to adjust the trigger level. You can click or tap the input field of **Level** to set the trigger level with the pop-up numeric keypad. For details, refer to descriptions in *Trigger Level*. The current trigger level is displayed in the trigger information label at the top of the screen.

8.7.8 Runt Trigger

This trigger mode is used to trigger pulses that pass through one trigger level but fail to pass through another trigger level, as shown in the figure below.

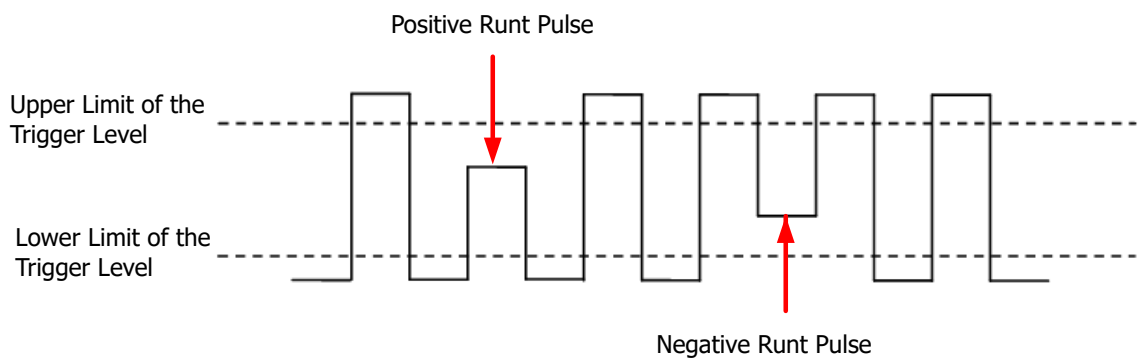

Figure 8.15 Runt Trigger

Trigger Type

Click or tap the drop-down button of **Type** to select "Runt" from the drop-down list. Then set the parameters for Runt trigger.

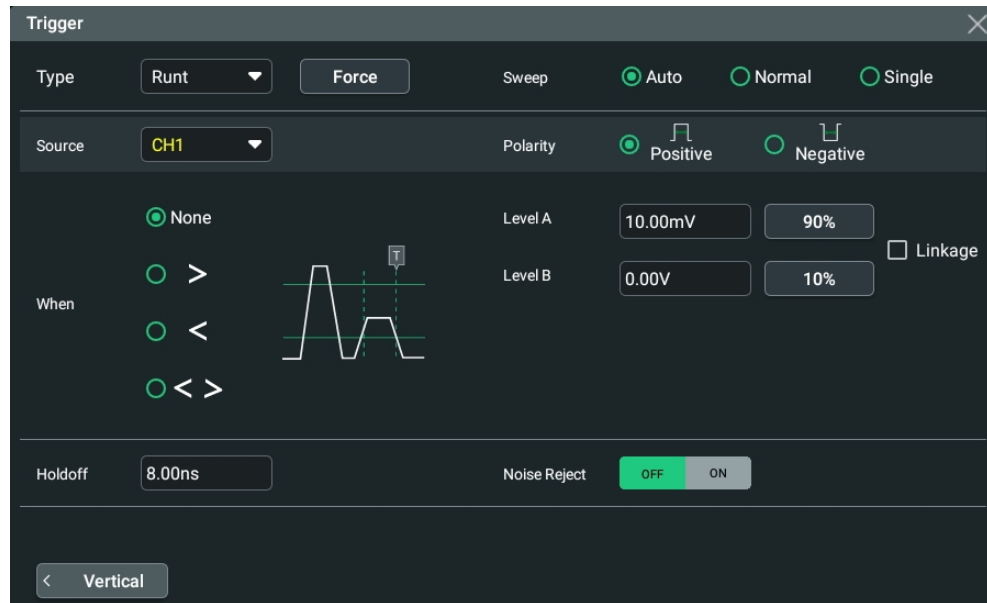

Figure 8.16 Runt Trigger Setting Menu

After selecting the trigger type, and then the current trigger setting information (including trigger type, trigger source, and trigger level) is displayed at the top of the screen, as shown in the figure below. The information will change based on the trigger settings.





Source Selection

Click or tap the drop-down button of **Source** to select CH1~CH4. For details, refer to descriptions in *Trigger Source*. The current trigger source is displayed in the trigger information label at the top of the screen.

Only when we select the channel (that has been input with signals) as the trigger source, can we obtain a stable trigger.

Polarity

Selects the pulse polarity of Runt trigger under the **Polarity** menu.

- Positive : triggers on the positive runt pulse.
- Negative : triggers on the negative runt pulse.

Trigger Condition

Sets the Runt trigger condition in the **When** menu.

- **None**: indicates not setting the trigger condition of Runt trigger.
- **>**: triggers when the runt pulse width is greater than the lower limit of pulse width. Click or tap the input field of **Lower** to set the minimum pulse width of Runt trigger with the pop-up numeric keypad.
- **<**: triggers when the runt pulse width is smaller than the upper limit of pulse width. Click or tap the input field of **Upper** to set the maximum pulse width of Runt trigger with the pop-up numeric keypad.
- **< >**: triggers when the runt pulse width is greater than the lower limit and smaller than the upper limit of pulse width. Click or tap the input field of **Upper** to set the maximum pulse width of Runt trigger with the pop-up numeric keypad. Click or tap the input field of **Lower** to set the minimum pulse width of Runt trigger with the pop-up numeric keypad. The lower limit of the pulse width must be smaller than the upper limit.

Level Selection and Setting

After the trigger condition setting is completed, you need to adjust the trigger level to correctly trigger the signal and obtain a stable waveform.

- Level A: only adjusts the upper limit of the trigger level, and the lower limit of the trigger level remains unchanged.
- Level B: only adjusts the lower limit of the trigger level, and the upper limit of the trigger level remains unchanged.

When setting the trigger level, first select a level type and then tap the "Trigger" icon

on the secondary screen, rotate the knob  at the upper-right part of the secondary screen to adjust the trigger level. You can also click or tap the input field of **Level A** and **Level B** to set the level of Source A and Source B with the pop-up numeric keypad. For details, refer to descriptions in *Trigger Level*. The current trigger level is displayed in the trigger information label at the top of the screen.

Check the checkbox of **Linkage** to link Level A and Level B.

Trigger Mode

In **Sweep** menu, select Auto, Normal, or Single as the trigger mode. For details, refer to descriptions in *Trigger Mode*.

Trigger Parameter Setting

Sets the trigger parameters (trigger holdoff and noise rejection) under this trigger type. For details, refer to descriptions in *Trigger Holdoff* and *Noise Rejection*.

8.7.9 Window Trigger

Window trigger provides a high trigger level and a low trigger level. The instrument triggers when the input signal passes through the high trigger level or the low trigger level.

Trigger Type

Click or tap the drop-down button of **Type** to select "Window" from the drop-down list. Then set the parameters for Window trigger.

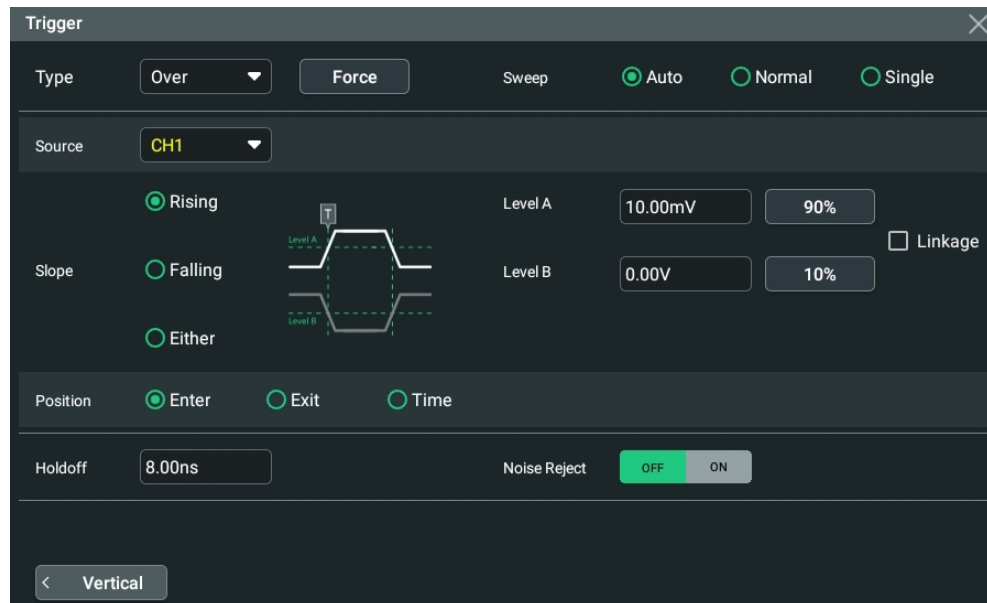

Figure 8.17 Window Trigger Setting Menu

After selecting the trigger type, and then the current trigger setting information (including trigger type, trigger source, and trigger level) is displayed in the trigger information label at the top of the screen, as shown in the figure below. The information will change based on the trigger settings.



Source Selection

Click or tap the drop-down button of **Source** to select CH1~CH4. For details, refer to descriptions in *Trigger Source*. The current trigger source is displayed in the trigger information label at the top of the screen.

Only when we select the channel (that has been input with signals) as the trigger source, can we obtain a stable trigger.

Edge Type

Selects the input signal edge (under the **Slope** menu) on which the oscilloscope triggers.

- **Rising:** triggers on the rising edge of the input signal when the voltage level is higher than the preset high trigger level.
- **Falling:** triggers on the falling edge of the input signal when the voltage level is lower than the preset low trigger level.
- **Either:** triggers on the rising or falling edge of the input signal when the voltage level meets the preset trigger level.

Trigger Position

After selecting the window type, click **Position** to further specify the time point of trigger by selecting the trigger position.

- **Enter:** triggers when the input signal enters the specified trigger level range.
- **Exit:** triggers when the input signal exits the specified trigger level range.
- **Time:** triggers when the accumulated hold time since the input signal entered the specified trigger level range is equal to the window time. After you select this type, click or tap the input field of **Time** to set it by using the pop-up numeric keypad. The available range is from 8 ns to 10 s.

Level Selection and Setting

After the trigger condition setting is completed, you need to adjust the trigger level to correctly trigger the signal and obtain a stable waveform.

- **Level A:** only adjusts the upper limit of the trigger level, and the lower limit of the trigger level remains unchanged.
- **Level B:** only adjusts the lower limit of the trigger level, and the upper limit of the trigger level remains unchanged.

When setting the trigger level, first select a level type and then tap the "Trigger" icon

on the secondary screen, rotate the knob  at the upper-right part of the secondary screen to adjust the trigger level. You can also click or tap the input field of **Level A** and **Level B** to set the level of Source A and Source B with the pop-up numeric keypad. For details, refer to descriptions in *Trigger Level*. The current trigger level is displayed in the trigger information label at the top of the screen.

Check the checkbox of **Linkage** to link Level A and Level B.

Trigger Mode

In **Sweep** menu, select Auto, Normal, or Single as the trigger mode. For details, refer to descriptions in *Trigger Mode*.

Trigger Parameter Setting

Sets the trigger parameters (trigger holdoff and noise rejection) under this trigger type. For details, refer to descriptions in *Trigger Holdoff* and *Noise Rejection*.

8.7.10 Delay Trigger

In Delay trigger, you need to set Source A and Source B. The oscilloscope triggers when the time difference (ΔT) between the specified edges (Edge A and Edge B) of Source A and Source B meets the preset time limit, as shown in the figure below. Edge A and Edge B must be two neighboring edges.

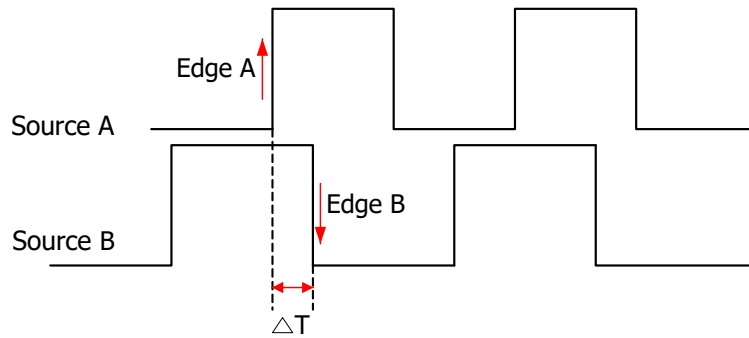

Figure 8.18 Delay Trigger

Trigger Type

Click or tap the drop-down button of **Type** to select "Delay" from the drop-down list. Then set the parameters for Delay trigger.

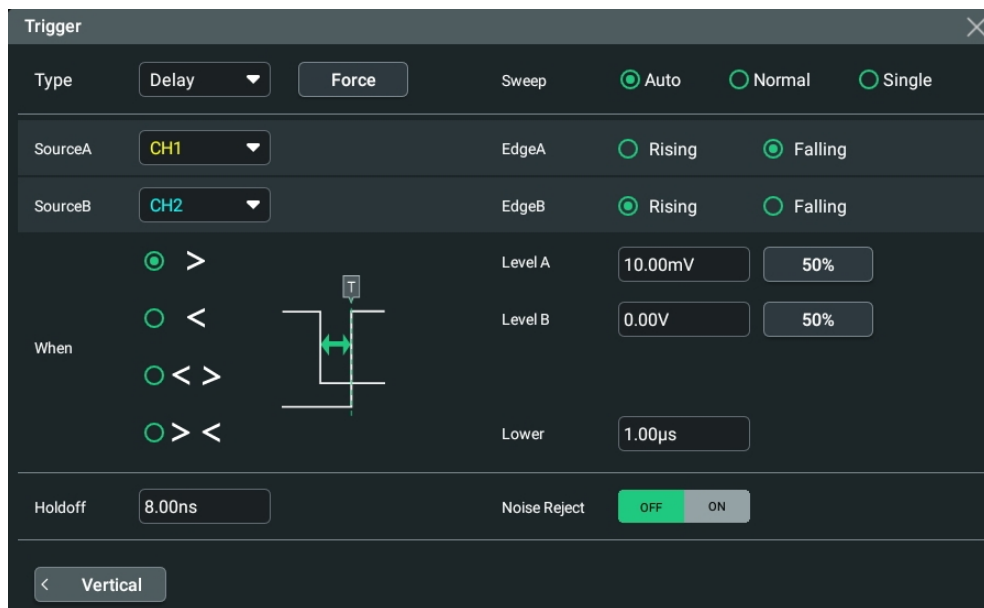

Figure 8.19 Delay Trigger Setting Menu

After selecting the trigger type, and then the current trigger setting information (including trigger type, trigger source, and trigger level) is displayed in the trigger information label at the top of the screen, as shown in the figure below. The information will change based on the trigger settings.



Source Setting

- **Source A:**

Click or tap the drop-down button of **SourceA** to select CH1~CH4. For details, refer to descriptions in *Trigger Source*. The current trigger source is displayed in the trigger information label at the top of the screen.

Only when we select the channel (that has been input with signals) as the trigger source, can we obtain a stable trigger.

- **Edge A:**

Click or tap the trigger edge type ("Rising" or "Falling") of Source A in Delay trigger under the **EdgeA** menu.

- **Source B:**

Click or tap the drop-down button of **SourceB** to select CH1~CH4. For details, refer to descriptions in *Trigger Source*. The current trigger source is displayed in the trigger information label at the top of the screen.

Only when we select the channel (that has been input with signals) as the trigger source, can we obtain a stable trigger.

- **Edge B:**

Click or tap the trigger edge type ("Rising" or "Falling") of Source B in Delay trigger under the **EdgeB** menu.

Set the Trigger Condition

Sets the time limit condition of Delay trigger in the **When** menu.

- **>**: triggers when the time difference (ΔT) between the specified edges of Source A and Source B is greater than the preset time lower limit. Click or tap the input field of **Lower** to set the delay time lower limit in Delay trigger with the pop-up numeric keypad.
- **<**: triggers when the time difference (ΔT) between the specified edges of Source A and Source B is smaller than the preset time upper limit. Click or tap the input field of **Upper** to set the delay time upper limit in Delay trigger with the pop-up numeric keypad.

- **< >**: triggers when the time difference (ΔT) between the specified edges of Source A and Source B is greater than the lower limit of the preset time and smaller than the upper limit of the preset time. Click or tap the input field of **Upper** to set the delay time upper limit in Delay trigger with the pop-up numeric keypad. Click or tap the input field of **Lower** to set the delay time lower limit in Delay trigger with the pop-up numeric keypad. The lower time limit must be smaller than the upper time limit.
- **> <**: triggers when the time difference (ΔT) between the specified edges of Source A and Source B is smaller than the lower limit of the preset time or greater than the upper limit of the preset time. Click or tap the input field of **Upper** to set the delay time upper limit in Delay trigger with the pop-up numeric keypad. Click or tap the input field of **Lower** to set the delay time lower limit in Delay trigger with the pop-up numeric keypad. The lower time limit must be smaller than the upper time limit.

Level Selection and Setting

After the trigger condition setting is completed, you need to adjust the trigger level to correctly trigger the signal and obtain a stable waveform.

- **Level A:**

Click or tap the input field of **Level A** to input the level of Source A with the pop-up numeric keypad. You can also tap the "Trigger" icon on the secondary screen,

then rotate the knob  at the upper-right part of the secondary screen to adjust the level of SourceA. For details, refer to descriptions in *Trigger Level*. The current trigger level is displayed in the trigger information label at the top of the screen.

- **Level B:**

Click or tap the input field of **Level B** to input the level of Source B with the pop-up numeric keypad. You can also tap the "Trigger" icon on the secondary screen,

then rotate the knob  at the upper-right part of the secondary screen to adjust the level of SourceB. For details, refer to descriptions in *Trigger Level*. The current trigger level is displayed in the trigger information label at the top of the screen.

Trigger Mode

In **Sweep** menu, select Auto, Normal, or Single as the trigger mode. For details, refer to descriptions in *Trigger Mode*.

Trigger Parameter Setting

Sets the trigger parameters (trigger holdoff and noise rejection) under this trigger type. For details, refer to descriptions in *Trigger Holdoff* and *Noise Rejection*.

8.7.11 Setup/Hold Trigger

In setup&hold trigger, you need to set the clock source and data source. The setup time starts when the data signal passes the trigger level and ends at the coming of the specified clock edge; the hold time starts at the coming of the specified clock edge and ends when the data signal crosses the trigger level again, as shown in the figure below. The oscilloscope triggers when the setup time or hold time is smaller than the preset time.

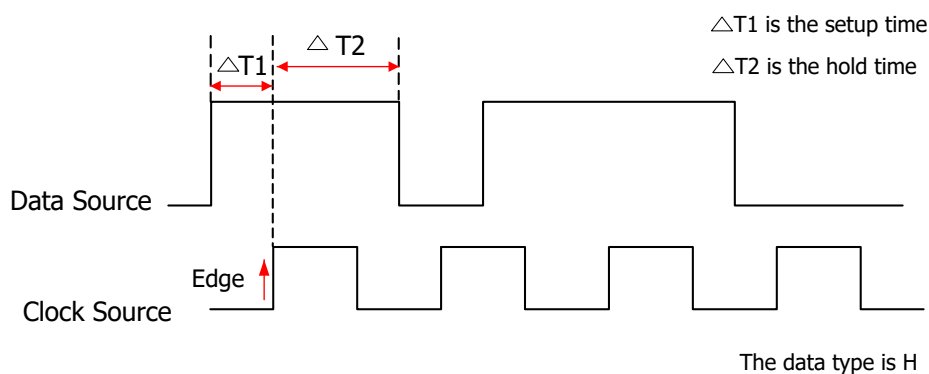

Figure 8.20 Setup/Hold Trigger

Trigger Type

Click or tap the drop-down button of **Type** to select "Setup/Hold" from the drop-down list. Then set the parameters for Setup/Hold trigger.

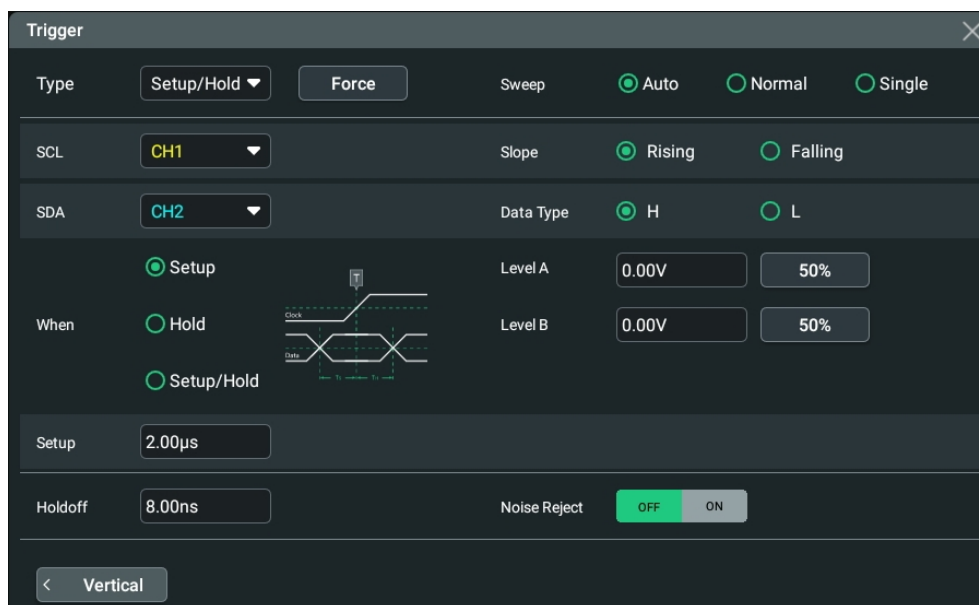

Figure 8.21 Setup/Hold Trigger Setting Menu

After selecting the trigger type, and then the current trigger setting information (including trigger type, trigger source, and trigger level) is displayed at the top of the

screen, as shown in the figure below. The information will change based on the trigger settings.



Clock Source

Click or tap the drop-down button of **SCL** to select CH1~CH4. For details, refer to descriptions in CH1~CH4. The current trigger source is displayed in the trigger information label at the top of the screen.

Only when we select the channel (that has been input with signals) as the trigger source, can we obtain a stable trigger.

Edge Type

Selects the desired clock edge type under the **Slope** menu, and it can be set to "Rising" or "Falling".

Data Source

Click or tap the drop-down button of **SDA** to select CH1~CH4. For details, refer to descriptions in CH1~CH4. The current trigger source is displayed in the trigger information label at the top of the screen.

Only when we select the channel (that has been input with signals) as the trigger source, can we obtain a stable trigger.

Data Type

Selects the desired item under the **Data Type** menu to set the effective pattern of the data signal. It can be set to H (high level) or L (low level).

Trigger Condition

Sets the Setup/Hold trigger condition in the **When** menu.

- **Setup**: the oscilloscope triggers when the setup time is smaller than the specified setup time. After selecting this type, click or tap the input field of **Setup** to set the setup time with the pop-up numeric keypad.
- **Hold**: the oscilloscope triggers when the hold time is smaller than the specified hold time. After selecting this type, click or tap the input field of **Hold** to set the hold time with the pop-up numeric keypad.
- **Setup/Hold**: the oscilloscope triggers when the setup time or hold time smaller than the specified time value. After selecting this type, click or tap the input field of **Setup** and **Hold** respectively to set the setup and hold time with the pop-up numeric keypad.

Trigger Mode

In **Sweep** menu, select Auto, Normal, or Single as the trigger mode. For details, refer to descriptions in *Trigger Mode*.

Trigger Parameter Setting

Sets the trigger parameters (trigger holdoff and noise rejection) under this trigger type. For details, refer to descriptions in *Trigger Holdoff* and *Noise Rejection*.

Level Selection and Setting

- **Level A**

After the trigger condition setting is completed, you need to adjust the trigger level to correctly trigger the signal and obtain a stable waveform.

Click or tap the input field of **Level A** to input the level of clock source with the pop-up numeric keypad. You can also tap the "Trigger" icon on the secondary

screen, then rotate the knob  at the upper-right part of the secondary screen to adjust the level of clock source. For details, refer to descriptions in *Trigger Level*. The current trigger level is displayed in the trigger information label at the top of the screen.

- **Level B**

After the trigger condition setting is completed, you need to adjust the trigger level to correctly trigger the signal and obtain a stable waveform.

Click or tap the input field of **Level B** to input the level of data source with the pop-up numeric keypad. You can also tap the "Trigger" icon on the secondary

screen, then rotate the knob  at the upper-right part of the secondary screen to adjust the level of data source. For details, refer to descriptions in *Trigger Level*. The current trigger level is displayed in the trigger information label at the top of the screen.

8.7.12 Nth Edge Trigger

Triggers on the Nth edge that appears after the specified idle time. For example, in the waveform shown in the figure below, the instrument should trigger on the second rising edge after the specified idle time (the time between two neighboring rising edges), and the idle time should be within the range between P and M ($P < \text{Idle Time} < M$). Wherein, M is the time between the first rising edge and its previous rising edge; P is the maximum time between the rising edges that participate in counting.

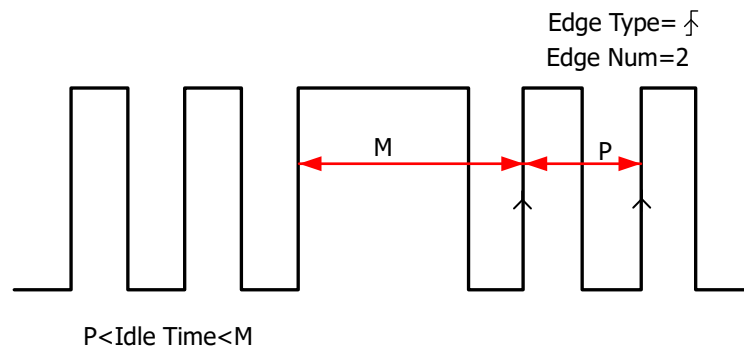

Figure 8.22 Nth Edge Trigger

Trigger Type

Click or tap the drop-down button of **Type** to select "Nth Edge" from the drop-down list. Then set the parameters for Nth Edge trigger.

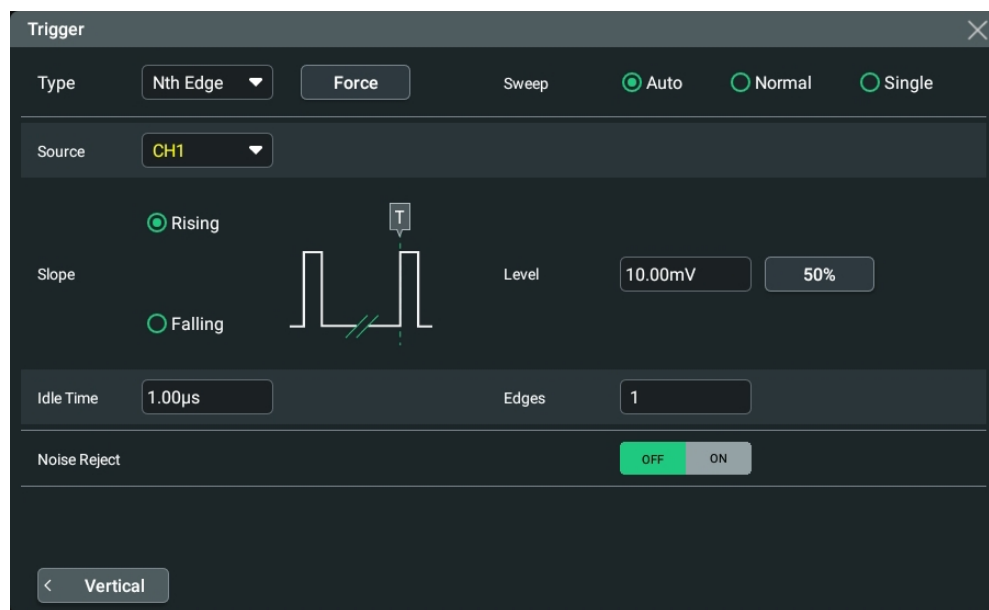

Figure 8.23 Nth Edge Trigger Setting Menu

After selecting the trigger type, and then the current trigger setting information (including trigger type, trigger source, and trigger level) is displayed in the trigger information label at the top of the screen, as shown in the figure below. The information will change based on the trigger settings.



Source Selection

Click or tap the drop-down button of **Source** to select CH1~CH4. For details, refer to descriptions in *Trigger Source*. The current trigger source is displayed in the trigger information label at the top of the screen.

Only when we select the channel (that has been input with signals) as the trigger source, can we obtain a stable trigger.

Edge Type

Select the input signal edge (under the **Slope** menu) on which the oscilloscope triggers.

- Rising: triggers on the rising edge of the input signal when the voltage level meets the specified trigger level.
- Falling: triggers on the falling edge of the input signal when the voltage level meets the specified trigger level.

Idle Time

Click or tap the input field of **Idle Time**, then use the pop-up numeric keypad to set the idle time before the edge counting in Nth edge trigger.

Edge Count

Click or tap the input field of **Edges**, then use the pop-up numeric keypad to set the value of "N" in Nth edge trigger. The available range is from 1 to 65,535.

Trigger Mode

In **Sweep** menu, select Auto, Normal, or Single as the trigger mode. For details, refer to descriptions in *Trigger Mode*.

Trigger Parameter Setting

Sets the trigger parameter (noise rejection) under this trigger type. For details, refer to descriptions in *Noise Reject*.

Trigger Level

Tap the "Trigger" icon on the secondary screen. When the multifunction knob selects

the trigger function, rotate the knob  at the upper-right part of the secondary screen to adjust the trigger level. You can also click or tap the input field of **Level** to set the trigger level with the pop-up numeric keypad. For details, refer to descriptions in *Trigger Level*. The current trigger level is displayed in the trigger information label at the top of the screen.

8.7.13 RS232 Trigger (Option)

RS232 bus is a serial communication mode used in data transmission between PCs or between a PC and a terminal. In RS232 serial protocol, a character is transmitted as a frame of data. The frame consists of 1 start bit, 5-8 data bits, 1 check bit, and 1-2 stop bits. Its format is as shown in the figure below. DS80000 series oscilloscope triggers when the start frame, error frame, check error, or the specified data of the RS232 signal is detected.

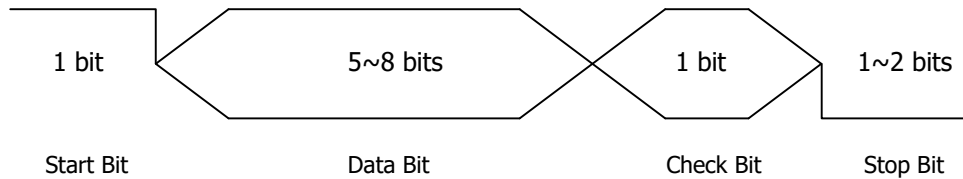

Figure 8.24 Schematic Diagram of RS232 Protocol

Trigger Type

Click or tap the drop-down button of **Type** to select "RS232" from the drop-down list. Then set the parameters for RS232 trigger.

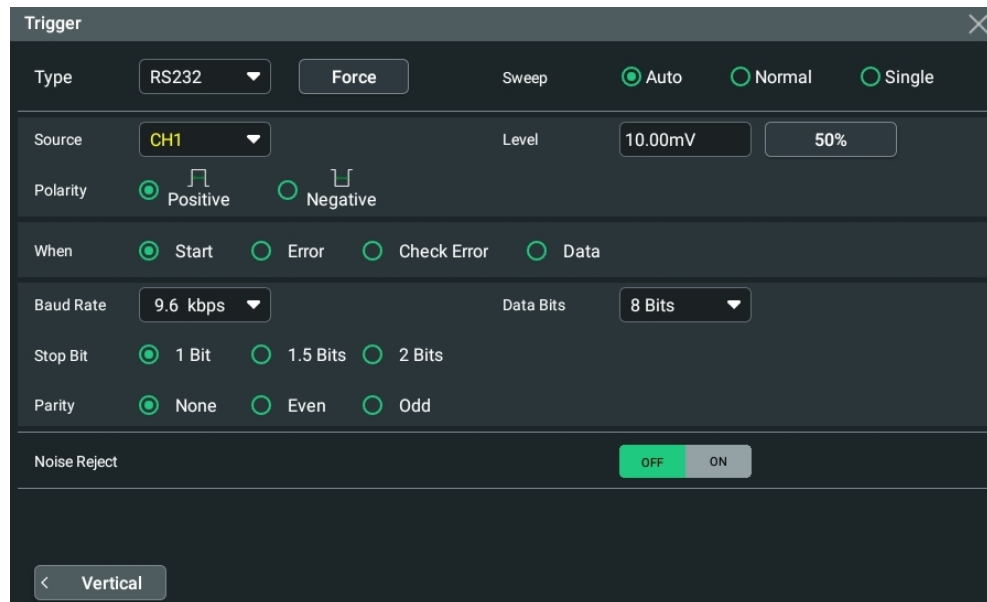
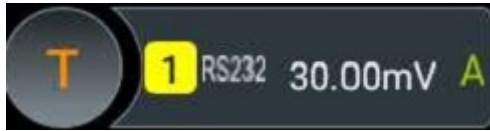

Figure 8.25 RS232 Trigger Setting Menu

After selecting the trigger type, and then the current trigger setting information (including trigger type, trigger source, and trigger level) is displayed at the top of the screen, as shown in the figure below. The information will change based on the trigger settings.





Source Selection

Click or tap the drop-down button of **Source** to select CH1~CH4. For details, refer to descriptions in *Trigger Source*. The current trigger source is displayed in the trigger information label at the top of the screen.

Only when we select the channel (that has been input with signals) as the trigger source, can we obtain a stable trigger.

Polarity

Selects the polarity of data transmission under the **Polarity** menu. It can be set to "Positive"  or "Negative" .

Trigger Condition

Sets the the desired trigger condition in the **When** menu.

- Start: triggers on the start frame position.
- Error: triggers when an error frame is detected.
- Check Error: triggers when a check error is detected.
- Data: triggers on the last bit of the preset data bits. Click or tap the input field of **Data**, and then use the pop-up numeric keypad to set the data of RS232 trigger.

Baud Rate

Sets the baud rate of data transmission (i.g. specifies a clock frequency). Click or tap the drop-down button of **Baud Rate**, then select the preset baud rate from the drop-down list. The available baud rates include 50 bps, 75 bps, 110 bps, 134 bps, 150 bps, 300 bps, and etc.

Data Bits

Indicate the number of bits per frame. Click or tap the drop-down button of **Data Bits** to select the desired data bits. The available data bits include "5 Bits", "6 Bits", "7 Bits", and "8 Bits".

Stop Bit

Stop Bit: indicates when to stop outputting data. Selects the desired stop bit under the **Stop Bit** menu. The available data bits include 1 Bit, 1.5 Bits, and 2 Bits.

Parity

Used to check whether the data are properly transmitted. Selects None, Even, or Odd under the **Parity** menu.

Trigger Mode

In **Sweep** menu, select Auto, Normal, or Single as the trigger mode. For details, refer to descriptions in *Trigger Mode*.

Trigger Parameter Setting

Sets the trigger parameter (noise rejection) under this trigger type. For details, refer to descriptions in *Noise Reject*.

Trigger Level

Tap the "Trigger" icon on the secondary screen, then rotate the knob  at the upper-right part of the secondary screen to adjust the trigger level. Also you can set the trigger level with the pop-up numeric keypad. For details, refer to descriptions in *Trigger Level*. The current trigger level is displayed in the trigger information label at the top of the screen.

8.7.14 I2C Trigger (Option)

I2C is a 2-wire serial bus used to connect the microcontroller and its peripheral device. It is a bus standard widely used in the microelectronic communication control field.

The I2C serial bus consists of SCL and SDA. Its transmission rate is determined by SCL, and its transmission data is determined by SDA, as shown in the figure below. The instrument series triggers on the start condition, restart, stop, missing acknowledgment, specific device address, or data value. Besides, it can also trigger on the specific device address and data values at the same time.

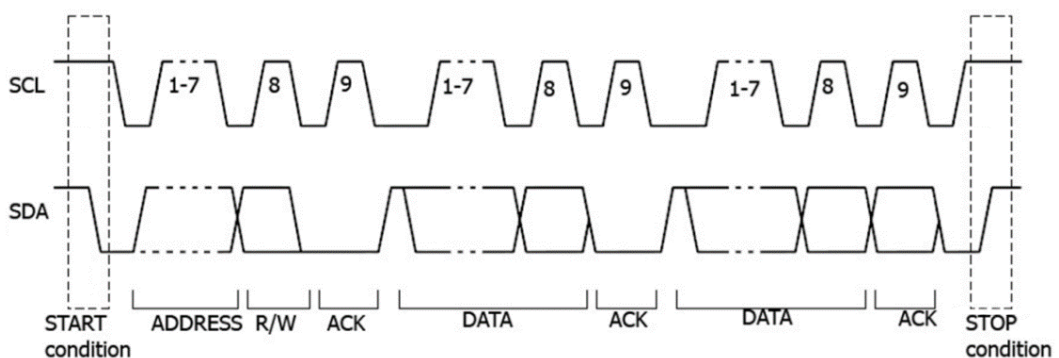

Figure 8.26 Schematic Diagram of I2C Protocol

Trigger Type

Click or tap the drop-down button of **Type** to select "I2C" from the drop-down list. Then set the parameters for I2C trigger.

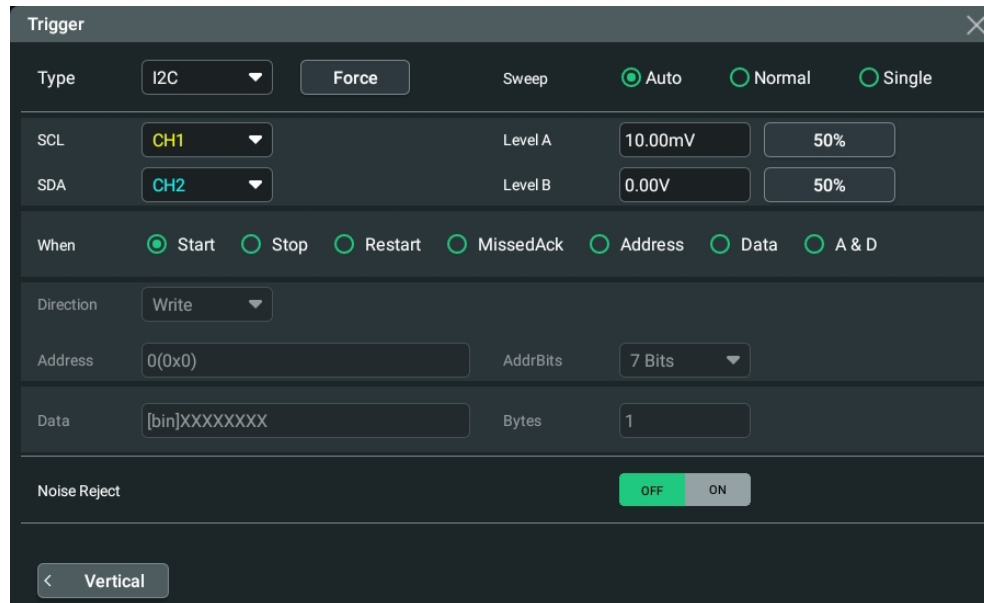
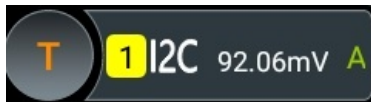

Figure 8.27 I2C Trigger Setting Menu

At this time, the current trigger setting information (including trigger type, trigger source, and trigger level) is displayed at the top of the screen, as shown in the figure below. The information will change based on the trigger settings.



Source Selection

Click or tap the drop-down button of **SCL** and **SDA** to select CH1~CH4 as the sources of SCL and SDA respectively. For details, refer to descriptions in *Trigger Source*. The current trigger source is displayed in the trigger information label at the top of the screen.

Only when we select the channel (that has been input with signals) as the trigger source, can we obtain a stable trigger.

Trigger Condition

Sets the the desired trigger condition in the **When** menu.

- **Start:** triggers when SDA data transitions from high level to low level while SCL is high level.
- **Stop:** triggers when SDA data transitions from low level to high level while SCL is high level.

- **Restart:** triggers when another start condition occurs before a stop condition.
- **MissedAck:** triggers when the SDA data is high level during any acknowledgment of SCL clock position.
- **Address:** the trigger searches for the specified address value. When this event occurs, the oscilloscope will trigger on the read/write bit. After this trigger condition is selected:
 - Click or tap the drop-down button of **Direction** to select "Write", "Read", or "R/W".

This setting is not available when **AddrBits** is set to "8 Bits".
 - Click or tap the drop-down button of **AddrBits** to select the desired address bits. The available address bits are "7 Bits", "8 Bits", and "10 Bits".
 - Click or tap the input field of **Address**, and then use the pop-up numeric keypad to set the address of I2C trigger.
- **Data:** the trigger searches for the specified data value on the data line (SDA). When this event occurs, the oscilloscope will trigger on the clock line (SCL) transition edge of the last bit of data. After this trigger condition is selected, you can set the length of bytes, the address width, and data.
 - Click or tap the input field of **Bytes**, and then use the pop-up numeric keypad to set the length of the data. Its range is from 1 to 5.
 - Click or tap the drop-down button of **AddrBits** to select the desired address bits. The available address bits are "7 Bits", "8 Bits", and "10 Bits".
 - Click or tap the input field of **Data**, and then the "Format" interface is will displayed. As shown in the figure below, you can select "Bin" or "Hex" format to set the data format.

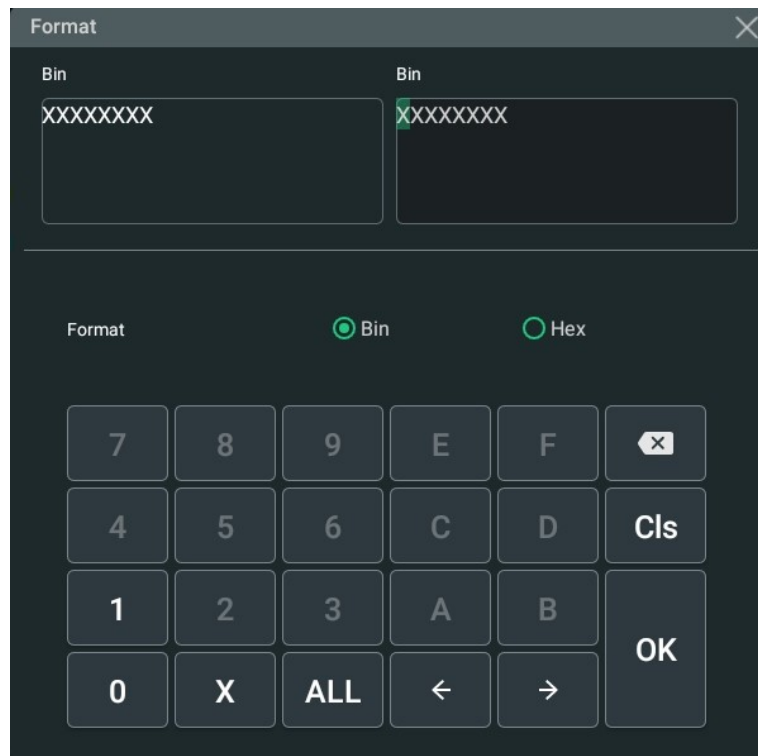

Figure 8.28 Bin Format Setting

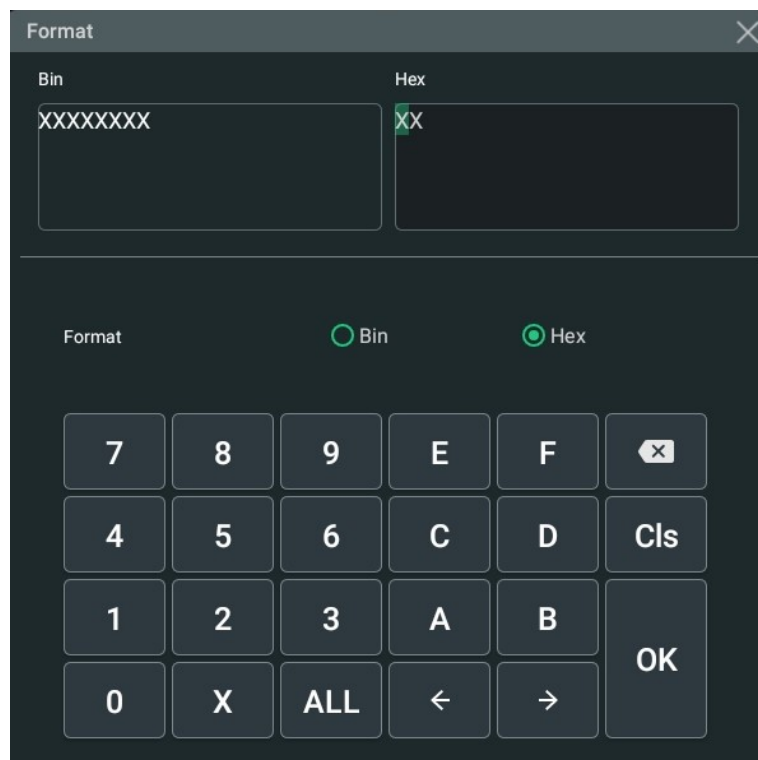

Figure 8.29 Hex Format Setting

- **A&D:** the oscilloscope searches for the specified address and data at the same time, then triggers when both the address and data meet the conditions. After this condition is selected, you need to set the sub-menu items such as **Direction**,

Bytes, **AddrBits**, **Address**, and **Data**. For the setting methods, refer to descriptions in "Address" and "Data" conditions.

Trigger Mode

In **Sweep** menu, select Auto, Normal, or Single as the trigger mode. For details, refer to descriptions in *Trigger Mode*.

Trigger Parameter Setting

Sets the trigger parameter (noise rejection) under this trigger type. For details, refer to descriptions in *Noise Reject*.

Level Selection and Setting

- **Level A**

After the trigger condition setting is completed, you need to adjust the trigger level to correctly trigger the signal and obtain a stable waveform.

Click or tap the input field of **Level A** to input the level of SCL with the pop-up numeric keypad. You can also tap the "Trigger" icon on the secondary screen,

then rotate the knob  at the upper-right part of the secondary screen to adjust the level of SCL. For details, refer to descriptions in *Trigger Level*. The current trigger level is displayed in the trigger information label at the top of the screen.

- **Level B**

After the trigger condition setting is completed, you need to adjust the trigger level to correctly trigger the signal and obtain a stable waveform.

Click or tap the input field of **Level B** to input the level of SDA with the pop-up numeric keypad. You can also tap the "Trigger" icon on the secondary screen,

then rotate the knob  at the upper-right part of the secondary screen to adjust the level of SDA. For details, refer to descriptions in *Trigger Level*. The current trigger level is displayed in the trigger information label at the top of the screen.

8.7.15 SPI Trigger (Option)

In SPI trigger, after the CS or timeout condition is satisfied, the oscilloscope triggers when the specified data is found. When using SPI trigger, you need to specify the CLK clock sources and MISO data sources.

Below is the sequential chart of SPI bus.

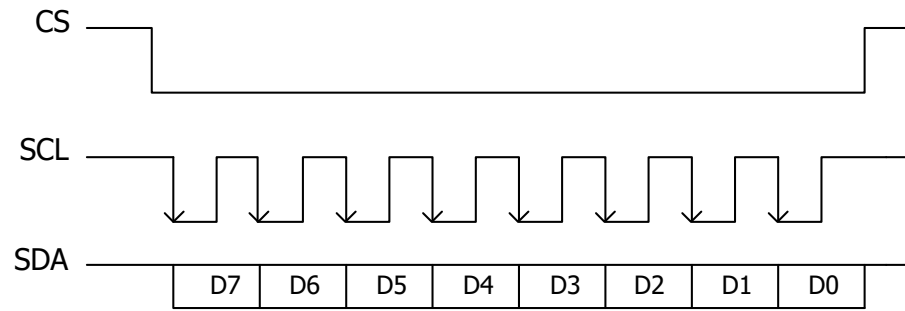

Figure 8.30 Sequential Chart of SPI Bus

Trigger Type

Click or tap the drop-down button of **Type** to select "SPI" from the drop-down list. Then set the parameters for SPI trigger.

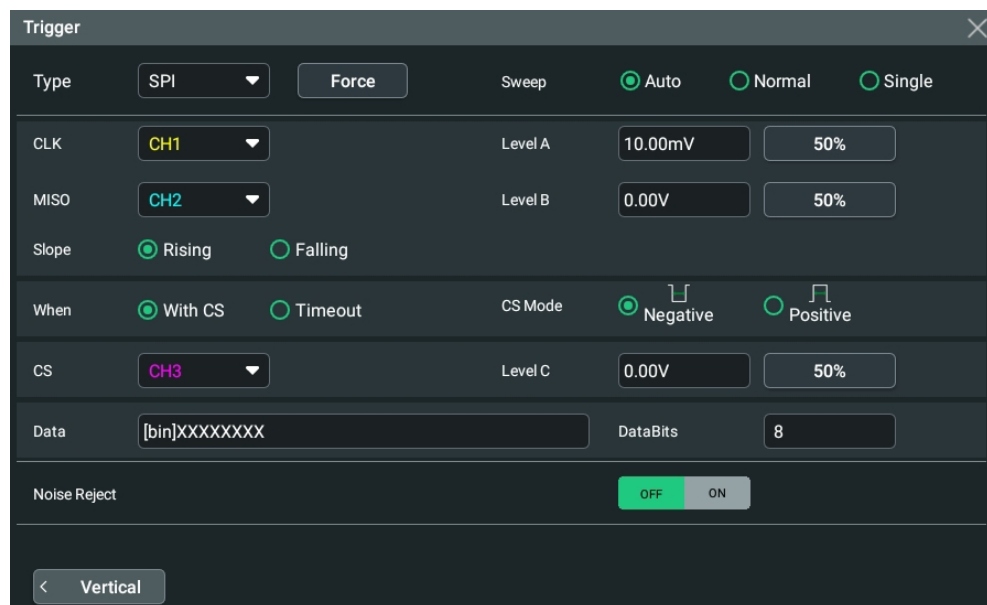
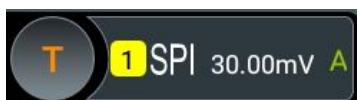

Figure 8.31 SPI Trigger Setting Menu

After selecting the trigger type, and then the current trigger setting information (including trigger type, trigger source, and trigger level) is displayed in the trigger information label at the top of the screen, as shown in the figure below. The information will change based on the trigger settings.



Source Selection

Click or tap the drop-down button of **CLK** and **MISO** to select CH1~CH4 as the sources of CLK and MISO respectively. For details, refer to descriptions in *Trigger*

Source. The current trigger source is displayed in the trigger information label at the top of the screen.

Only when we select the channel (that has been input with signals) as the trigger source, can we obtain a stable trigger.

Edge Type

Selects the desired clock edge type under **Slope**.

- Rising: samples the MISO data on the rising edge of the clock.
- Falling: samples the MISO data on the falling edge of the clock.

Trigger Condition

Selects the desired trigger condition under **When**.

- With CS: if the CS signal is valid, the oscilloscope will trigger when the data (SDA) satisfying the trigger conditions is found.
 - Click or tap the drop-down button of **CS** to select CH1~CH4 as the CS signal line.
 - After selecting this condition, you can click or tap "Positive" (high level is valid) or "Negative" (low level is valid) under **CS Mode**.
- Timeout: the oscilloscope starts to search for the data (MISO) on which to trigger after the clock signal (CLK) stays in the idle state for a specified period of time. After selecting this condition, you can click or tap **Timeout**, then use the numeric keypad to set the idle time. The range is from 8 ns to 10 s.

Data

Click or tap the of field of **Data**, and then the "Format" interface is will displayed. You can set the data bit that needs to be operated on. For details, refer to descriptions in *I2C Trigger (Option)*.

Data Bits

Click or tap the input field of **DataBits**, and then use the pop-up numeric keypad to set the number of bits in the serial data string. The number of bits in the string can be set to any integer ranging from 4 to 32.

Trigger Mode

In **Sweep** menu, select Auto, Normal, or Single as the trigger mode. For details, refer to descriptions in *Trigger Mode*.

Trigger Parameter Setting

Sets the trigger parameter (noise rejection) under this trigger type. For details, refer to descriptions in *Noise Reject*.

Level Selection and Setting

- **Level A:**

After the trigger condition setting is completed, you need to adjust the trigger level to correctly trigger the signal and obtain a stable waveform.

Click or tap the input field of **Level A** to input the level of CLK with the pop-up numeric keypad. You can also tap the "Trigger" icon on the small screen, then

rotate the knob  at the upper-right part of the small screen to adjust the level of CLK. For details, refer to descriptions in *Trigger Level*. The current trigger level is displayed in the trigger information label at the top of the screen.

- **Level B:**

After the trigger condition setting is completed, you need to adjust the trigger level to correctly trigger the signal and obtain a stable waveform.

Click or tap the input field of **Level B** to input the level of MISO with the pop-up numeric keypad. You can also tap the "Trigger" icon on the small screen, then

rotate the knob  at the upper-right part of the small screen to adjust the level of MISO. For details, refer to descriptions in *Trigger Level*. The current trigger level is displayed in the trigger information label at the top of the screen.

8.7.16 CAN Trigger (Option)

DS80000 can trigger on the start of a frame, end of a frame, frame of the specified type (e.g. Remote, Overload, Data, etc.), or error frame of the specified type (e.g. Answer Error, Check Error, Format Error, etc.) of the CAN signal.

The data frame format of the CAN bus is as shown in the figure below.

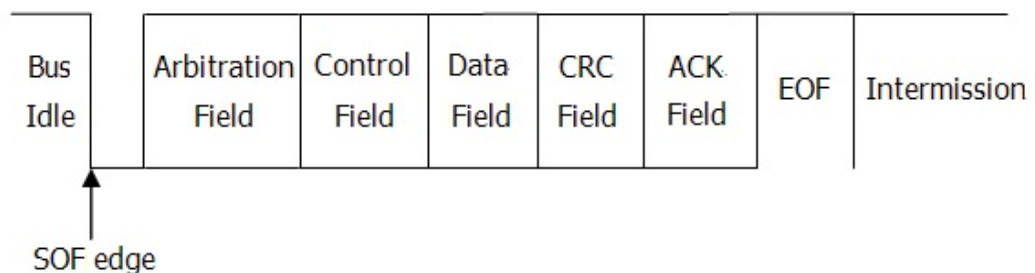

Figure 8.32 Data Frame Format of the CAN Bus

Trigger Type

Click or tap the drop-down button of **Type** to select "CAN" from the drop-down list. Then set the parameters for CAN trigger.

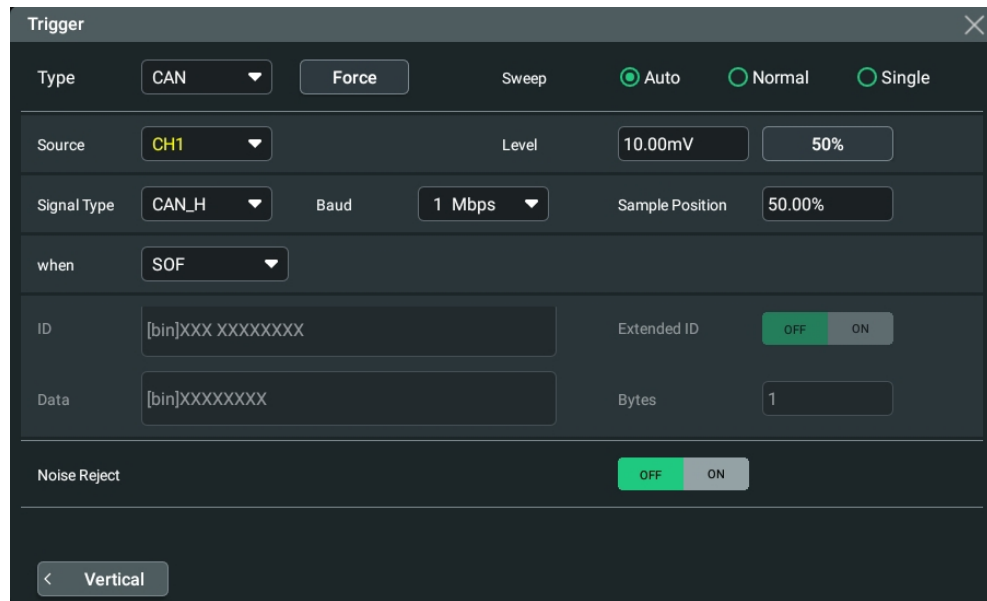
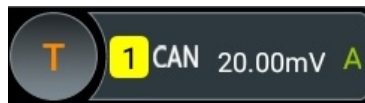

Figure 8.33 CAN Trigger Setting Menu

After selecting the trigger type, and then the current trigger setting information (including trigger type, trigger source, and trigger level) is displayed in the trigger information label at the top of the screen, as shown in the figure below. The information will change based on the trigger settings.



Source Selection

Click or tap the drop-down button of **Source** to select CH1~CH4. For details, refer to descriptions in *Trigger Source*. The current trigger source is displayed in the trigger information label at the top of the screen.

Only when we select the channel (that has been input with signals) as the trigger source, can we obtain a stable trigger.

Signal Type

Click or tap the drop-down button of **Signal Type** to select the desired signal type.

- CAN_H: indicates the actual CAN_H bus signal.
- CAN_L: indicates the actual CAN_L bus signal.
- TX/RX: indicates the Transmit signal and Receive signal from the CAN bus transceiver.

- Differential: The CAN differential bus signals connected to an analog source channel by using a differential probe. Connect the probe's positive lead to the CAN_H bus signal and connect the negative lead to the CAN_L bus signal.

Baud Rate

Set the baud rate of the signal. Click or tap the drop-down button of **Baud** to select the preset baud rate from the drop-down list. The available baud rates include 10 kbps, 20 kbps, 33.3 kbps, 50 kbps, 62.5 kbps, 83.3 kbps, and etc.

Sample Position

Sample position is a point within a bit's time. The oscilloscope samples the bit level at this point. The sample position is represented by the proportion of "the time from the start of the bit to the sample position" to the "bit time", as shown in the figure below.

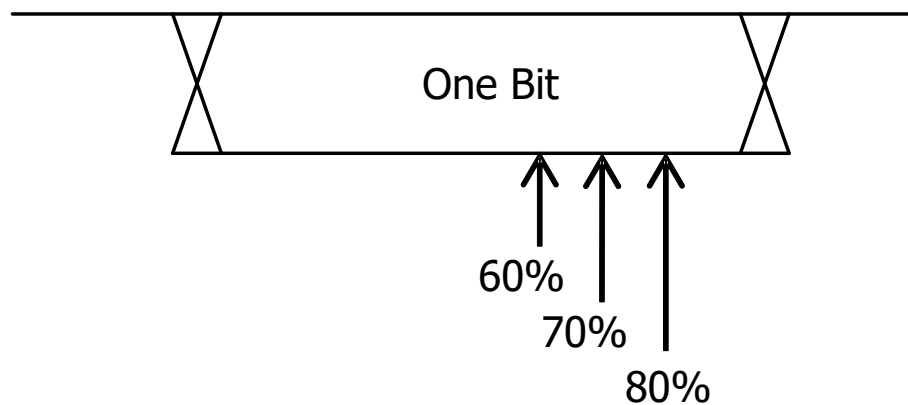

Figure 8.34 Sample Position

Click or tap the input field of **Sample Position** to set it by using the pop-up numeric keypad. The settable range is from 10% to 90%.

Trigger Condition

Click or tap the drop-down button of **When** to select the desired trigger condition.

- SOF: triggers at the start of a frame.
- EOF: triggers at the end of a frame.
- Remote ID: triggers on the specified ID of Remote frame. When you select **Remote ID**, you need to set the following parameters.
 - Click or tap the ON/OFF tab for the **Extended ID** menu to enable or disable the extended ID.
 - Click or tap the input field of **Data**, and then the "Format" interface is displayed. You can set the data bit that needs to be operated on. For details, refer to descriptions in *I2C Trigger (Option)*.

- Overload: triggers on the overload frames.
- Frame ID: triggers on the data frames with the specified ID. When you select **Frame ID**, you need to set the following parameters.
 - Click or tap the ON/OFF tab for the **Extended ID** menu to enable or disable the extended ID.
 - Click or tap the input field of **Data**, and then the "Format" interface is displayed. You can set the data bit that needs to be operated on. For details, refer to descriptions in *I2C Trigger (Option)*.
- Frame Data: triggers on the data frames with the specified Data. When you select **Frame Data**, you need to set the following parameters.

Click or tap the input field of **Data**, and then the "Format" interface is displayed. You can set the data bit that needs to be operated on. For details, refer to descriptions in *I2C Trigger (Option)*.
- Data & ID: triggers on the data frames with the specified ID and data. When you select **Data & ID**, click or tap to select "Data" or "ID" under the **Define** menu. When you select "Data", click or tap the input field of **Data**, and then the "Format" interface is displayed. You can set the data bit that needs to be operated on. For details, refer to descriptions in *I2C Trigger (Option)*. When you select "ID", you need to set the following parameters.
 - Click or tap the ON/OFF tab for the **Extended ID** menu to enable or disable the extended ID.
 - Click or tap the input field of **Data**, and then the "Format" interface is displayed. You can set the data bit that needs to be operated on. For details, refer to descriptions in *I2C Trigger (Option)*.
- Frame Error: triggers on the error frame.
- Bit Fill: triggers on the error frame with the bit fill.
- Answer Error: triggers on the answer error frame.
- Check Error: triggers on the check error frame.
- Format Error: triggers on the format error frame.
- Random Error: triggers on the random error frame, such as the format error frame, answer error frame, etc.

Trigger Mode

In **Sweep** menu, select Auto, Normal, or Single as the trigger mode. For details, refer to descriptions in *Trigger Mode*.

Trigger Parameter Setting

Sets the trigger parameter (noise rejection) under this trigger type. For details, refer to descriptions in *Noise Reject*.

Trigger Level

Tap the "Trigger" icon on the secondary screen, then rotate the knob  at the upper-right part of the secondary screen to adjust the trigger level. Also you can set the trigger level with the pop-up numeric keypad. For details, refer to descriptions in *Trigger Level*. The current trigger level is displayed in the trigger information label at the top of the screen.

8.7.17 FlexRay Trigger (Option)

DS80000 can trigger on the specified frame, symbol, error, or position of the FlexRay bus. FlexRay is a type of differential serial bus configured with three consecutive segments (i.g. packet header, payload, and packet trailer). Its data transmission rate is up to 10 Mb/s. Each frame contains a static segment and a dynamic segment, and ends with the bus idle time.

Its format is as shown in the figure below.

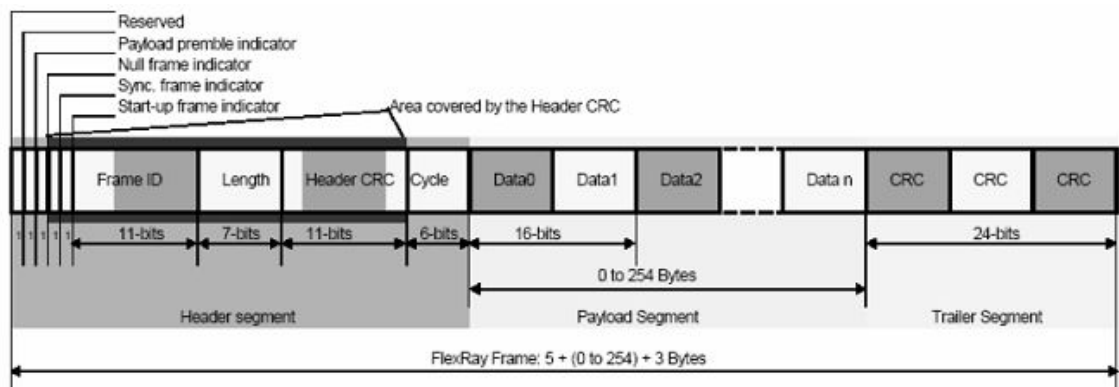

Figure 8.35 Frame Format of FlexRay Bus

Trigger Type

Click or tap the drop-down button of **Type** to select "FlexRay" from the drop-down list. Then set the parameters for FlexRay trigger.

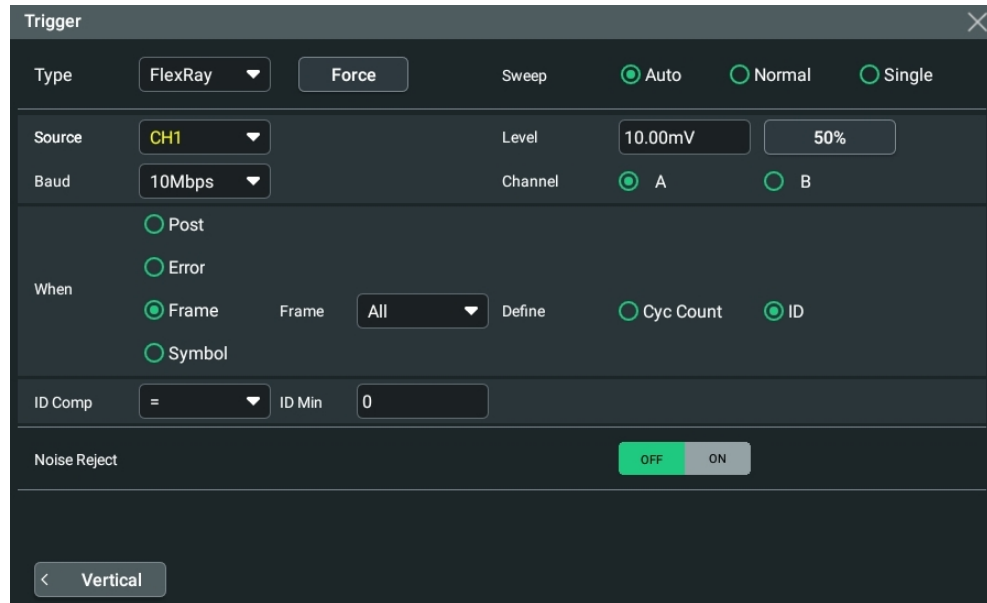

Figure 8.36 FlexRay Trigger Setting Menu

After selecting the trigger type, and then the current trigger setting information (including trigger type, trigger source, and trigger level) is displayed in the trigger information label at the top of the screen, as shown in the figure below. The information will change based on the trigger settings.



Source Selection

Click or tap the drop-down button of **Source** to select CH1~CH4. For details, refer to descriptions in *Trigger Source*. The current trigger source is displayed in the trigger information label at the top of the screen.

Only when we select the channel (that has been input with signals) as the trigger source, can we obtain a stable trigger.

Baud Rate

Set the baud rate of the signal. Click or tap the drop-down button **Baud** to select a FlexRay baud rate that matches the FlexRay bus signal. Select the preset baud rate from the drop-down list. The available baud rates include 2.5 Mbps, 5 Mbps, and 10 Mbps.

Trigger Condition

Click or tap the drop-down button of **When** to select the desired trigger condition.

- Post: triggers on the specified position of the FlexRay bus. Select **Post** as the trigger condition, and then click or tap its drop-down button to select "TSS End", "FSS_BSS End", "FES End", or "DTS End" from the drop-down list.
- Frame: triggers on the frame of FlexRay bus.
 - Click or tap the drop-down button of **Frame** to select the frame type. The types of frames include null, Syns, Start, and All.
 - Select "ID" or "Cyc Count" under the **Define** menu.

When you select "Cyc Count", set the following parameters: Cyc Comp, Count Min, and Count Max. Click or tap the drop-down button of **Cyc Comp** to select the comparison conditions. The available choices include =, ≠, >, <, ><, and <>. When a certain condition is selected, click or tap the input field of **Count Min** or **Count Max**, then set the number of cycles with the pop-up numeric keypad.

When you select "ID", set the following parameters: ID Comp, ID Min, and ID Max. Click or tap the drop-down button of **ID Comp** to select the comparison conditions. The available choices include =, ≠, >, <, ><, and <>. When a certain condition is selected, click or tap the input field of **ID Max** or **ID Min**, then use the numeric keypad to set the frame ID.

- Symbol: triggers on the CAS/MTS (Collision Avoidance Symbol/Media Access Test Symbol) and WUP (Wakeup Pattern) of FlexRay bus.
 - Click or tap the drop-down button of **Symbol** to select the symbol type. The symbol type includes CAS/MTS and WUS.
 - Click or tap the drop-down button of **ID Comp** to select the comparison conditions. The available choices include =, ≠, >, <, ><, and <>. When a certain condition is selected, click or tap the input field of **ID Max** or **ID Min**, then use the numeric keypad to set the frame ID.
- Error: triggers when an error occurs to the FlexRay bus. Click or tap the drop-down button of **Error** to select the error type. It includes Head CRC Err, Tail CRC Err, Decode Err, and Random Err.

As the occurrence possibility of specified FlexRay frame is very low, it is recommended that you set the oscilloscope to "Normal" trigger mode when the trigger condition is set to "Frame", so as to prevent the instrument from triggering automatically while waiting for the specified frame. The same goes for "Error" trigger condition. In addition, when multiple FlexRay errors occur at the same time, you need to adjust the trigger holdoff so as to view the specific error.

Trigger Mode

In **Sweep** menu, select Auto, Normal, or Single as the trigger mode. For details, refer to descriptions in *Trigger Mode*.

Trigger Parameter Setting

Sets the trigger parameter (noise rejection) under this trigger type. For details, refer to descriptions in *Noise Reject*.

Trigger Level

Tap the "Trigger" icon on the secondary screen, then rotate the knob  at the upper-right part of the secondary screen to adjust the trigger level. Also you can set the trigger level with the pop-up numeric keypad. For details, refer to descriptions in *Trigger Level*. The current trigger level is displayed in the trigger information label at the top of the screen.

8.7.18 LIN Trigger (Option)

DS80000 series oscilloscope can trigger on the sync field of LIN signal, and can also trigger on the specified identifier, data, or frame.

The data frame format of the LIN bus is as shown in the figure below.

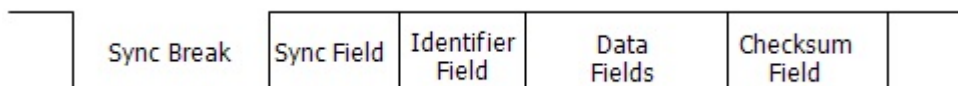

Figure 8.37 Data Frame Format of the LIN Bus

Trigger Type

Click or tap the drop-down button of **Type** to select "LIN" from the drop-down list. Then set the parameters for LIN trigger.

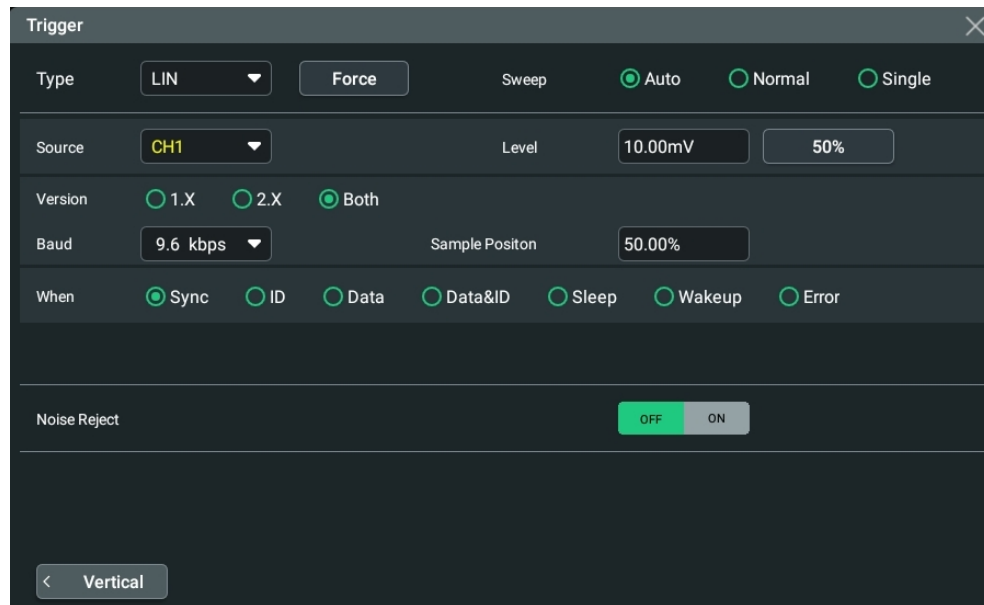

Figure 8.38 LIN Trigger Setting Menu

After selecting the trigger type, then the current trigger setting information (including trigger type, trigger source, and trigger level) is displayed in the trigger information label at the top of the screen, as shown in the figure below. The information will change based on the trigger settings.



Source Selection

Click or tap the drop-down button of **Source** to select CH1~CH4. For details, refer to descriptions in *Trigger Source*. The current trigger source is displayed in the trigger information label at the top of the screen.

Only when we select the channel (that has been input with signals) as the trigger source, can we obtain a stable trigger.

Protocol Version

In the **Version** menu, select the protocol version that matches the signal under test. The available versions include 1.X, 2.X and Both.

Baud Rate

Click or tap the drop-down button of the **Baud** menu to select the preset baud rate from the drop-down list. The available baud rates include 1.2 kbps, 2.4 kbps, 4.8 kbps, 9.6 kbps, 19.2 kbps, and etc.

Sample Position

Sample position is a point within a bit's time. The oscilloscope samples the bit level at this point. The sample position is represented by the proportion of "the time from the start of the bit to the sample position" to the "bit time", as shown in the figure below.

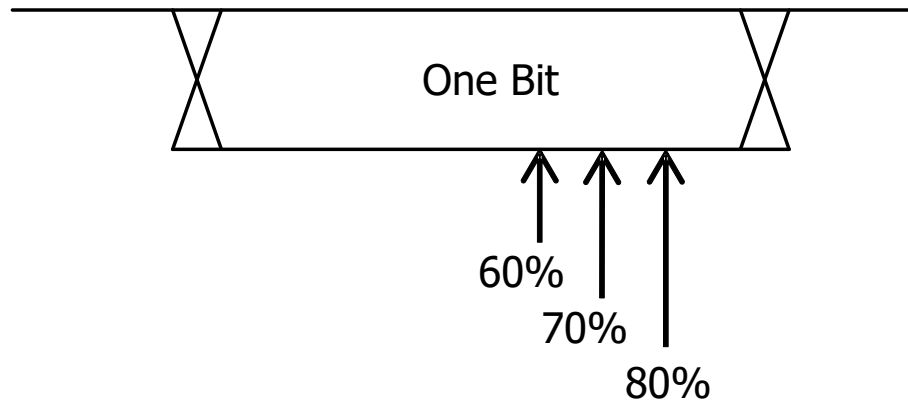

Figure 8.39 Sample Position

Click or tap the input field of **Sample Position** to set it by using the pop-up numeric keypad. The settable range is from 10% to 90%.

Trigger Condition

Click or tap the drop-down button of **When** to select the desired trigger condition.

- **Sync:** triggers on the last bit of the sync field.
- **ID:** triggers when the frames with the specified ID are found.

Click or tap the input field of **ID**, and then use the pop-up numeric keypad to set ID.

- **Data:** triggers when the data that meet the preset conditions are found.
 - Click or tap the input field of **Bytes**, and then use the pop-up numeric keypad to set the length of the data. Its range is from 1 to 8.
 - Click or tap the input field of **Data**, and then the "Format" interface is displayed. You can set the data bit that needs to be operated on. For details, refer to descriptions in *I2C Trigger (Option)*.
- **Data&ID:** triggers when the frames with the specified ID and data that meet the preset conditions are both found.
 - Click or tap the input field of **Bytes**, and then use the pop-up numeric keypad to set the length of the data. Its range is from 1 to 8.
 - Click or tap the input field of **ID**, and then use the pop-up numeric keypad to set ID.

- Click or tap the input field of **Data**, and then the "Format" interface is displayed. You can set the data bit that needs to be operated on. For details, refer to descriptions in *I2C Trigger (Option)*.
- **Sleep**: triggers when the sleep frame is found.
- **Wakeup**: triggers when the wakeup frame is found.
- **Error**: triggers on the specified type of error frame. Click or tap the drop-down button of **Error Type** to select the error type: Sync, Even Odd, or Check Sum.

Trigger Mode

In **Sweep** menu, select Auto, Normal, or Single as the trigger mode. For details, refer to descriptions in *Trigger Mode*.

Trigger Parameter Setting

Sets the trigger parameter (noise rejection) under this trigger type. For details, refer to descriptions in *Noise Reject*.

Trigger Level

Tap the "Trigger" icon on the secondary screen, then rotate the knob  at the upper-right part of the secondary screen to adjust the trigger level. Also you can set the trigger level with the pop-up numeric keypad. For details, refer to descriptions in *Trigger Level*. The current trigger level is displayed in the trigger information label at the top of the screen.

8.7.19 I2S Trigger (Option)

In I2S trigger, the oscilloscope searches for the specified data value and take it as the condition for identifying the trigger. You need to specify the serial clock line (SCLK, 1 pulse is found on the clock line once 1 bit of digital audio data is sent), frame clock line (WS, used for switch the audio channel data), and serial data line (SDA, used for transmit audio data represented in binary (2's complement)).

Below is the sequential chart of I2S bus.

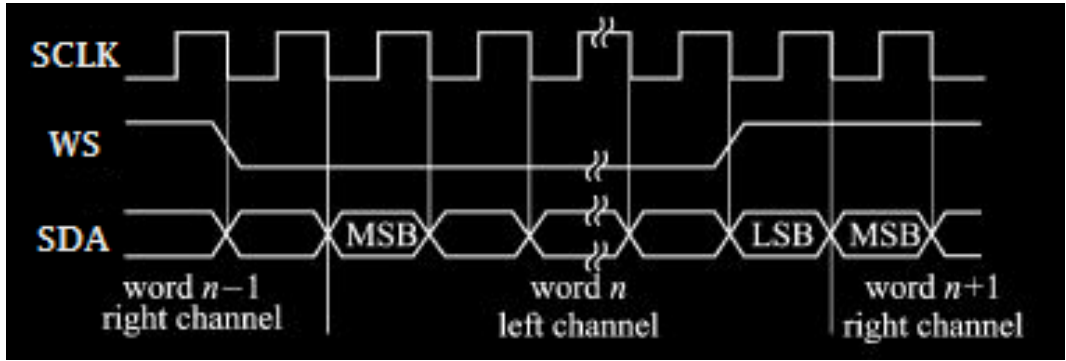

Figure 8.40 Sequential Chart of I2S Bus

Trigger Type

Click or tap the drop-down button of **Type** to select "I2S" from the drop-down list. Then set the parameters for I2S trigger.

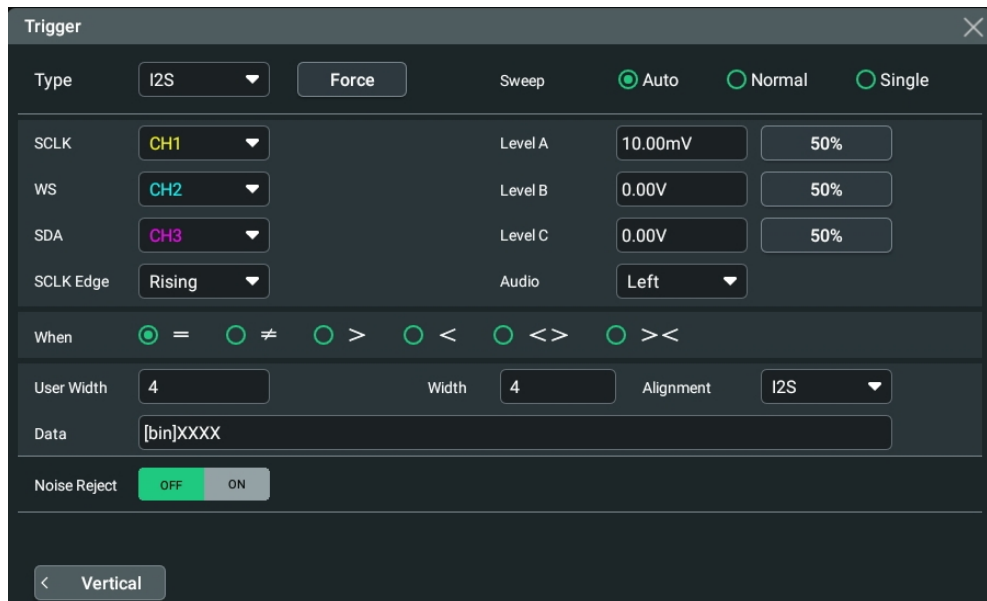
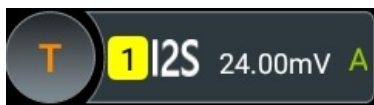

Figure 8.41 I2S Trigger Setting Menu

After selecting the trigger type, then the current trigger setting information (including trigger type, trigger source, and trigger level) is displayed in the trigger information label at the top of the screen, as shown in the figure below. The information will change based on the trigger settings.



Source Selection

Click or tap the drop-down button of **SCLK**, **WS**, and **SDA** to select CH1~CH4 to specify the sources of SCLK, WS, and SDA respectively. For details, refer to descriptions in *Trigger Source*. The current trigger source is displayed in the trigger information label at the top of the screen.

Only when we select the channel (that has been input with signals) as the trigger source, can we obtain a stable trigger.

Edge Type

Selects the desired clock edge from the drop-down list of **SCLK Edge**.

- Rising: samples the SDA data on the rising edge of the clock.
- Falling: samples the SDA data on the falling edge of the clock.

Audio

Click or tap the drop-down button of **Audio** to select the audio channel ("Left", "Right", or "Either").

Trigger Condition

Click or tap the drop-down button of **When** to select the desired trigger condition.

- =: triggers when the channel's data equal the set data value. Click or tap the input field of **Data**, and then the "Format" interface is displayed. You can set the data bit that needs to be operated on. For details, refer to descriptions in *I2C Trigger (Option)*.
- ≠: triggers when the channel's data do not equal the set data value. Click or tap the input field of **Data**, and then the "Format" interface is displayed. You can set the data bit that needs to be operated on. For details, refer to descriptions in *I2C Trigger (Option)*.
- >: triggers when the channel's data are greater than the set data value. Click or tap the input field of **Data Min**, and then the "Format" interface is displayed. You can set the lower limit of the data bit. For details, refer to descriptions in *I2C Trigger (Option)*.
- <: triggers on when the channel's data are smaller than the set data value. Click or tap the input field of **Data Max**, and then the "Format" interface is displayed. You can set the upper limit of the data bit. For details, refer to descriptions in *I2C Trigger (Option)*.
- < >: triggers when the channel's data are smaller than the upper limit of the data value and greater than the lower limit of the data value.. Click or tap the input field of **Data Max** and **Data Min**, and then the "Format" interface is displayed. You can set the upper limit and lower limit of the data bit. For details, refer to descriptions in *I2C Trigger (Option)*.

- **> <**: triggers when the channel's data are greater than the upper limit of the data value and smaller than the lower limit of the data value. Click or tap the input field of **Data Max** and **Data Min**, and then the "Format" interface is displayed. You can set the upper limit and lower limit of the data bit. For details, refer to descriptions in *I2C Trigger (Option)*.

User Width

Click or tap the input field of **User Width** to set it by using the pop-up numeric keypad. Its range is from 4 to 32.

The user width is smaller than or equal to the width.

Width

Click or tap the input field of **Width** to set it by using the pop-up numeric keypad. Its range is from 4 to 32.

Alignment

Click or tap the drop-down button of **Alignment** to select the alignment way for data signal.

- **I2S**: MSB (Most Significant Bit) of data for each sample is sent first, and LSB (Least Significant Bit) is sent last. The MSB appears on the SDA line one bit clock after the edge of the WS transition.
- **LJ**: data transmission (MSB first) begins at the edge of the WS transition.
- **RJ**: data transmission (MSB first) is right-justified to the WS transition.

Trigger Mode

In **Sweep** menu, select Auto, Normal, or Single as the trigger mode. For details, refer to descriptions in *Trigger Mode*.

Trigger Parameter Setting

Sets the trigger parameter (noise rejection) under this trigger type. For details, refer to descriptions in *Noise Reject*.

Trigger Level

- **Level A**

Sets the trigger level of SCLK. Tap the "Trigger" icon on the secondary screen,

then rotate the knob  at the upper-right part of the secondary screen to adjust the trigger level. Also you can set the trigger level with the pop-up numeric keypad. For details, refer to descriptions in *Trigger Level*. The current trigger level is displayed in the trigger information label at the top of the screen.

- **Level B**

Sets the trigger level of WS. Tap the "Trigger" icon on the secondary screen, then rotate the knob  at the upper-right part of the secondary screen to adjust the trigger level. Also you can set the trigger level with the pop-up numeric keypad. For details, refer to descriptions in *Trigger Level*. The current trigger level is displayed in the trigger information label at the top of the screen.

- **Level C**

Sets the trigger level of SDA. Tap the "Trigger" icon on the secondary screen, then rotate the knob  at the upper-right part of the secondary screen to adjust the trigger level. Also you can set the trigger level with the pop-up numeric keypad. For details, refer to descriptions in *Trigger Level*. The current trigger level is displayed in the trigger information label at the top of the screen.

8.7.20 MIL-STD-1553 Trigger (Option)

1553B is the abbreviation for the MIL-STD-1553 bus. DS80000 can trigger on the sync field of 1553B bus, and can also trigger on the specified data word, command word, status word, or error type.

The command word, data word, and status word format of the 1553B bus is as shown in the figure below.

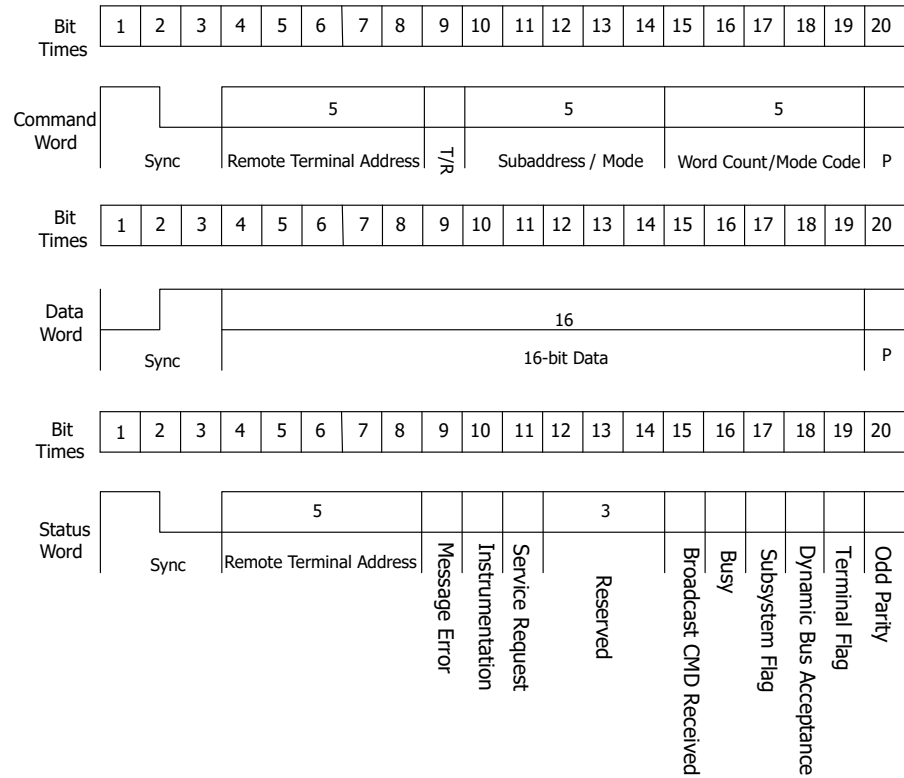

Figure 8.42 Formats of the Command Word, Data Word, and Status Word of the 1553B Bus

Trigger Type

Click or tap the drop-down button of **Type** to select "MIL-STD-1553" from the drop-down list. Then set the parameters for MIL-STD-1553 trigger.

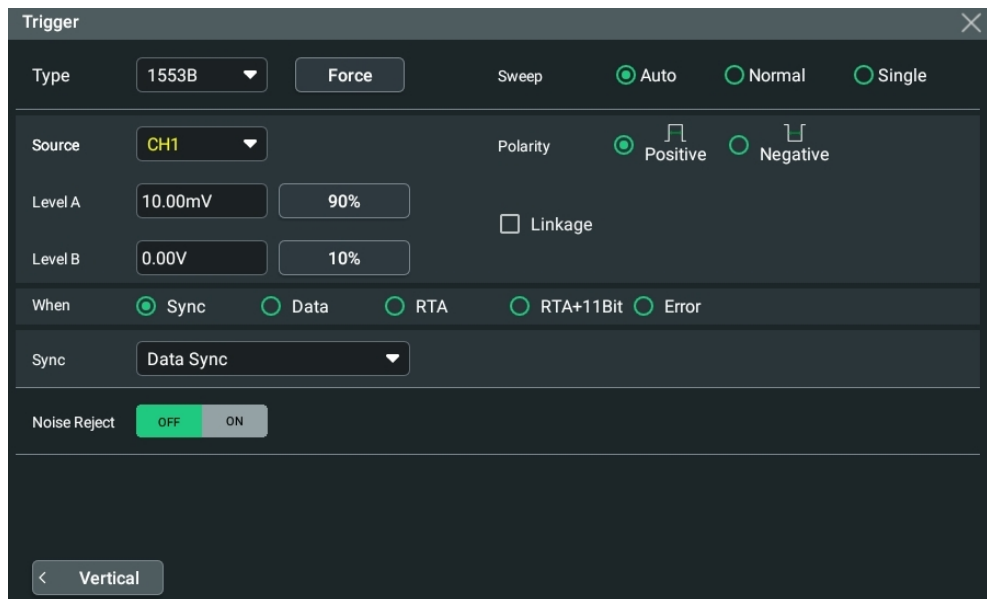

Figure 8.43 MIL-STD-1553 Trigger Setting Menu

After selecting the trigger type, and then the current trigger setting information (including trigger type, trigger source, and trigger level) is displayed in the trigger information label at the top of the screen, as shown in the figure below. The information will change based on the trigger settings.





Source Selection

Click or tap the drop-down button of **Source** to select CH1~CH4. For details, refer to descriptions in *Trigger Source*. The current trigger source is displayed in the trigger information label at the top of the screen.

Only when we select the channel (that has been input with signals) as the trigger source, can we obtain a stable trigger.

Polarity

Selects the desired polarity under the **Polarity** menu. The polarities available are positive polarity () and negative polarity ()

Level Selection and Setting

After the trigger condition setting is completed, you need to adjust the trigger level to correctly trigger the signal and obtain a stable waveform.

- Level A: only adjusts the upper limit of the trigger level, and the lower limit of the trigger level remains unchanged.
- Level B: only adjusts the lower limit of the trigger level, and the upper limit of the trigger level remains unchanged.

In MIL-STD-1553 trigger, pressing down the trigger level knob at the upper-right part of the small screen can quickly switch the current level adjustment type.

When setting the trigger level, first select a level type and then tap the "Trigger" icon

on the secondary screen, rotate the knob  at the upper-right part of the secondary screen to adjust the trigger level. You can also click or tap the input field of **Level A** and **Level B** menu item to adjust the level of Source A and Source B. For details, refer to descriptions in *Trigger Level*. The current trigger level is displayed in the trigger information label at the top of the screen.

Trigger Condition

Click or tap the drop-down button of **When** to select the desired trigger condition.

- **Sync:** triggers on the specified sync type. After this trigger condition is selected, click or tap the drop-down button of **Sync** to select the desired sync type: Data Sync, Cmd/Status Sync, or All Sync.
- **Data:** triggers on the specified data word. After this trigger condition is selected, click or tap the comparison conditions from the **Comp** menu. The available choices include =, ≠, >, <, ><, and <>.
 - =: triggers when the channel's data word equals the set data word. Click or tap the input field of **Min**, and then the "Format" interface is displayed. You can set the lower limit of the data word. For details, refer to descriptions in *I2C Trigger (Option)*.
 - ≠: triggers when the channel's data word does not equal the set data word. Click or tap the input field of **Min**, and then the "Format" interface is displayed. You can set the lower limit of the data word. For details, refer to descriptions in *I2C Trigger (Option)*.
 - >: triggers when the channel's data word is greater than the set data word. Click or tap the input field of **Min**, and then the "Format" interface is displayed. You can set the lower limit of the data word. For details, refer to descriptions in *I2C Trigger (Option)*.
 - <: triggers when the channel's data word is smaller than the set data word. Click or tap the input field of **Max**, and then the "Format" interface is displayed. You can set the upper limit of the data word. For details, refer to descriptions in *I2C Trigger (Option)*.
 - < >: triggers when the channel's data word is smaller than the upper limit of the data word and greater than the lower limit of the data word. Click or tap the input field of **Max** and **Min**, and then the "Format" interface is displayed. You can set the upper limit and lower limit of the data word. For details, refer to descriptions in *I2C Trigger (Option)*.
 - > <: triggers when the channel's data word is greater than the upper limit of the data word or smaller than the lower limit of the data word. Click or tap the input field of **Max** and **Min**, and then the "Format" interface is displayed. You can set the upper limit and lower limit of the data word. For details, refer to descriptions in *I2C Trigger (Option)*.
- **RTA:** triggers on the specified remote terminal address. After this trigger condition is selected, click or tap the input field of **RTA**, and then the "Format" interface is displayed. You can set the remote terminal address. For details, refer to descriptions in *I2C Trigger (Option)*.
- **RTA+11Bit:** triggers on the RTA and the remaining 11 bits.
After this trigger condition is selected:

- Click or tap the input field of **RTA**, and then the "Format" interface is displayed. You can set the remote terminal address. For details, refer to descriptions in *I2C Trigger (Option)*.
- Click or tap the input field of **Bit time**, and then the "Format" interface is displayed. You can set the bit time position value to 0 (low), 1 (high), or X (don't care). For details, refer to descriptions in *I2C Trigger (Option)*.
- **Error**: triggers on the specified error type. After this trigger condition is selected, click or tap the drop-down button of **Err Type** to select the error type.
 - **Sync Error**: triggers when an invalid sync pulse is found.
 - **Check Error**: triggers when the parity bit is incorrect for the data in the word.

Trigger Mode

In **Sweep** menu, select Auto, Normal, or Single as the trigger mode. For details, refer to descriptions in *Trigger Mode*.

Trigger Parameter Setting

Sets the trigger parameter (noise rejection) under this trigger type. For details, refer to descriptions in *Noise Reject*.

8.8 Trigger Output Connector



The trigger output connector (**[TRIG/PF Out]**) on the rear panel of DS80000 series can output trigger signals (hardware trigger) based on the current setting.

Click or tap the function navigation icon  at the lower-left corner of the screen, and then select "Utility" to enter the utility function menu. Click or tap **Setup**, and then in the **PF Out** menu, select "TrigOut". You can also tap the **Utility** icon on the small screen to enter the utility function menu. A signal which reflects the current oscilloscope capture rate can be output from **[TRIG/PF Out]** connector each time a trigger is generated by the oscilloscope. If this signal is connected to a waveform display device to measure the frequency, the measurement result is the same as the current capture rate.

If "PassFail" is selected for the **PF Out** menu, the instrument can output a pulse from the **[TRIG/PF Out]** connector when a pass/failed event is detected during the pass/fail test.

9 Math Operation

This series of oscilloscopes can realize multiple math operations between waveforms of different channels, including arithmetic operation, spectrum operation, logic operation, function operation, and digital filter. To enter the **Math** menu, perform any of the following operations:

- Click or tap the function navigation icon  at the lower-left corner of the screen, and then select **Math** to enter the "Math" menu.
- Click or tap the Math1-Math4 label at the bottom of the screen, and the corresponding interface appears on the screen, as shown in *Figure 9.2*. Click or tap the label again, or the icon  at the upper-right corner of the window to enter the math operation menu.

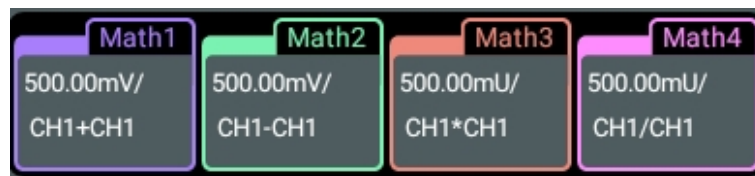

- Tap the **Math** icon on the secondary screen at the right side of the screen to enter the "Math" menu.

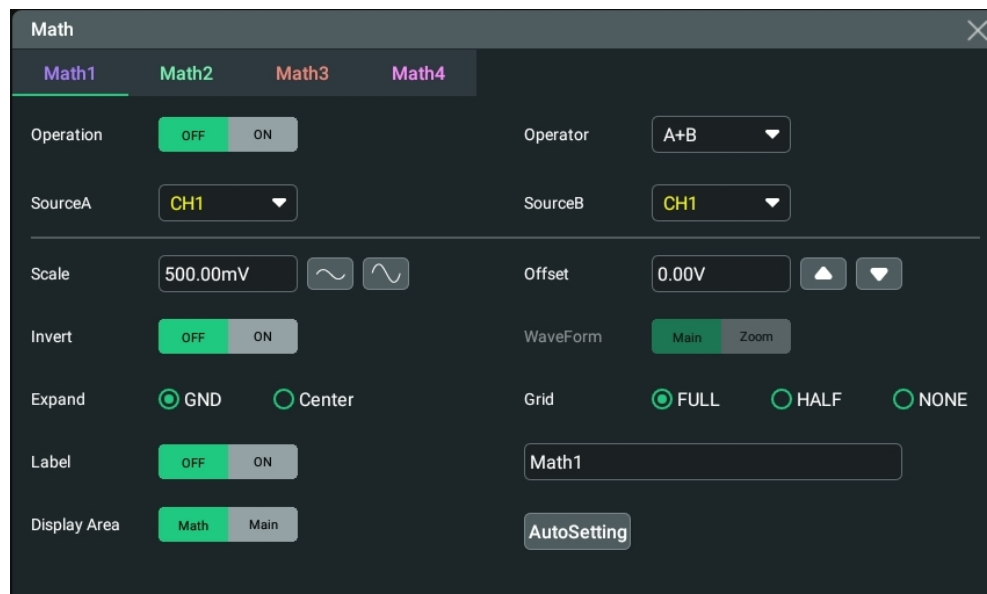

Figure 9.1 Math Operation Menu

This oscilloscope provides four math operations: Math1, Math2, Math3, and Math4. Users can select the math operation type by clicking or tapping the **Math1** ~ **Math4** tab or by sliding the menu left and right to select the desired **Math** menu item. This manual takes Math1 as an example to introduce math operation.

In the **Math** menu, click or tap the ON/OFF tab for the **Operation** menu to show or hide the waveform display window of the operation results. By default, it is OFF. When set to sON, the figure as shown in *Figure 9.2* is displayed on the screen.

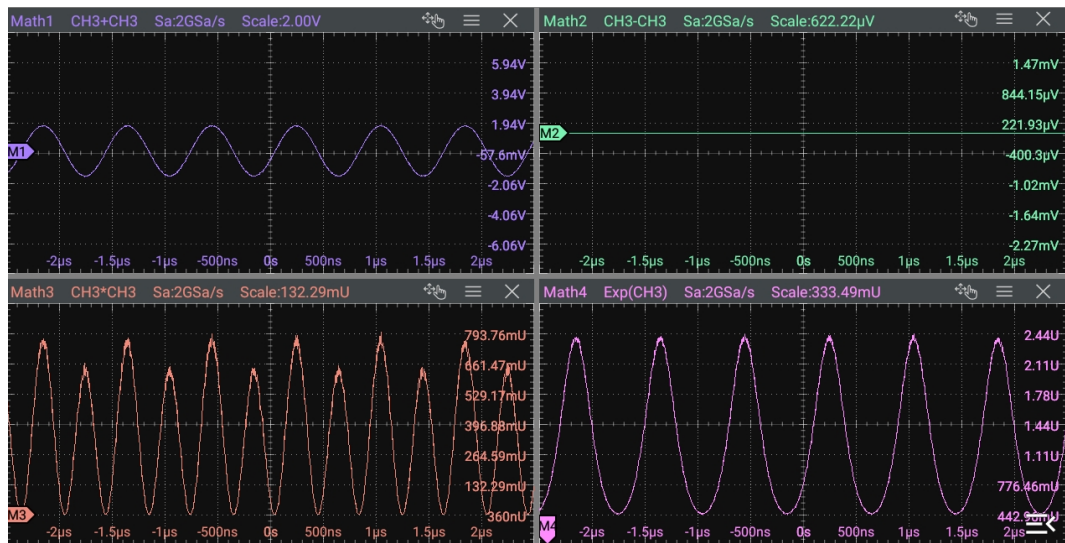



Figure 9.2 Operation Result Display Window

Users can drag the title bar of the display window to change the position of the window. You can also click/tap the close button  at the upper-right corner of the window to close it.

9.1 Arithmetic Operation

In the **Math** menu, click or tap **Operator** to select the desired math operation. The arithmetic operations supported by this oscilloscope include $A+B$, $A-B$, $A \times B$, and $A \div B$.

- **A+B:** adds the waveform voltage values of signal source A and B point by point and displays the results.
- **A-B:** subtracts the waveform voltage values of signal source B from that of source A point by point and displays the results.
- **A×B:** multiplies the waveform voltage values of signal source A and B point by point and displays the results.
- **A÷B:** divides the waveform voltage values of signal source A by that of source B point by point and displays the results. It can be used to analyze the Multiple relation of the two channels waveforms.

TIP

When the voltage of signal source B is 0 V, the division result is treated as 0.



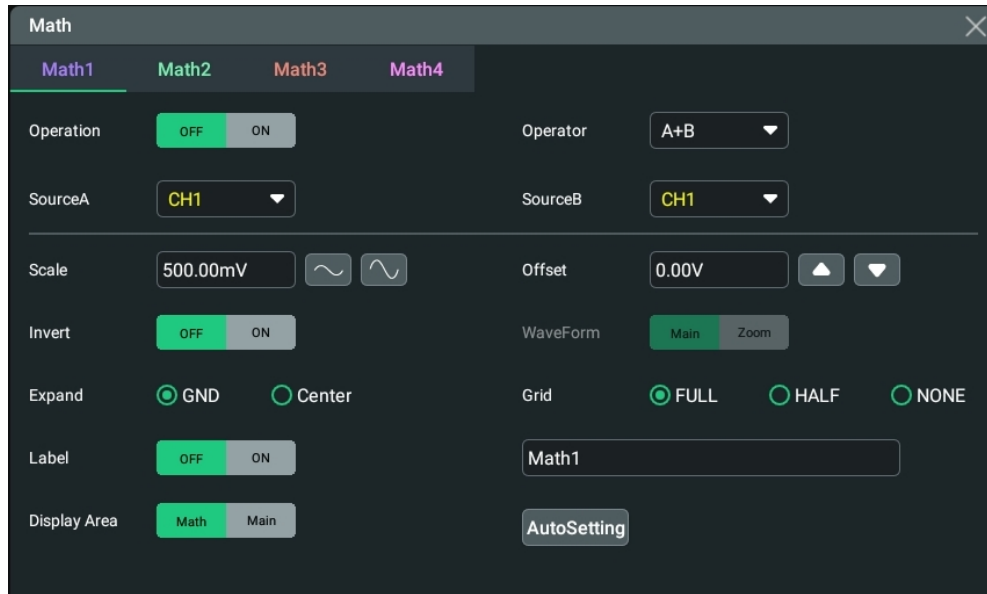

Figure 9.3 Arithmetic Operation Menu

Operation Result Display Window

Click or tap the ON/OFF tab for the **Operation** menu to enable or disable the display of the arithmetic operation result window. The source and the vertical scale parameters are displayed at the top of the window, as shown in the figure below.

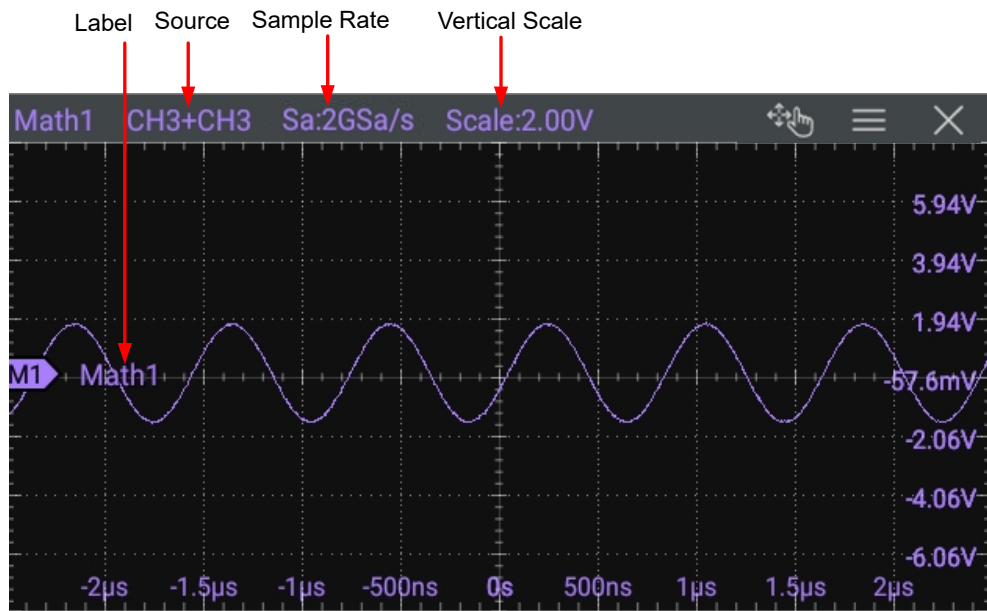

Figure 9.4 Operation Result Display Window

Source

Click or tap the drop-down button of **SourceA** or **SourceB** to select CH1~CH4, Ref1-Ref10. When a source channel is selected, the selected channel automatically switches to the ON state.

Scale

Scale is used to set the vertical scale of the operation result. For setting methods, refer to descriptions in *To Adjust the Vertical Scale*.

Offset

Offset is used to set the vertical offset of the operation result. For setting methods, refer to descriptions in *To Adjust the Vertical Offset*.

Invert

Invert is used to enable or disable the inverted display function of the waveform. For setting methods, refer to descriptions in *Waveform Invert*.

Waveform

This oscilloscope supports Main and Zoom. By default, it is Main.

- **MAIN:** indicates that the measurement range is within the main time base region.
- **ZOOM:** indicates that the measurement range is within the zoomed time base region.

When you select "Zoom", you need to enable *Delayed Sweep* in *To Set the Horizontal System*.

Expand

The oscilloscope supports two vertical expansion modes: GND and Center. By default, it is "GND".

- **GND:** when the vertical scale is changed, the math operation waveform will be expanded or compressed around the signal ground level position.
- **Center:** when the vertical scale is changed, the math operation waveform will be expanded or compressed around the screen center.

Auto Set

Click or tap **AutoSetting** to adjust the vertical scale and the offset of the operation results to the optimal value according to the current configuration, so as to better to observe.

Label

Label is used to set the label for the math operation results. For setting methods, refer to descriptions in *Channel Label*.

Grid

For setting methods, refer to the descriptions in *To Set the Screen Grid*.

Display Area

Click or tap to select "Math" or "Main" under **Display Area**.

- **Math:** when you select "Math", the waveforms of math operation are displayed in the math operation window.
- **Main:** when you select "Main", the waveforms of math operation are displayed in the main interface window.

9.2 Function Operation

In the **Math** menu, click or tap the drop-down button of **Operator** to select the desired function operation. The available function operation types of this oscilloscope include Intg, Diff, Sqrt, Lg (Base 10 Exponential), Ln, Exp, Abs, and AX+B.

- **Intg:** calculates the integral of the selected source. For example, you can use integral to measure the area under a waveform or the pulse energy.
- **Diff:** calculates the discrete time derivative of the selected source. For example, you can use differentiate to measure the instantaneous slope of a waveform.
- **Sqrt:** calculates the square roots of the selected source point by point and displays the results.
- **Lg (Base 10 Exponential):** calculates the base 10 exponential of the selected source point by point and displays the results.
- **Ln:** calculates the natural logarithm (Ln) of the selected source point by point and displays the results.
- **Exp:** calculates the exponential of the selected source point by point and displays the results.
- **Abs:** calculates the absolute value of the selected source and displays the results.
- **AX+B:** applies a linear function to the selected source, and displays the results.

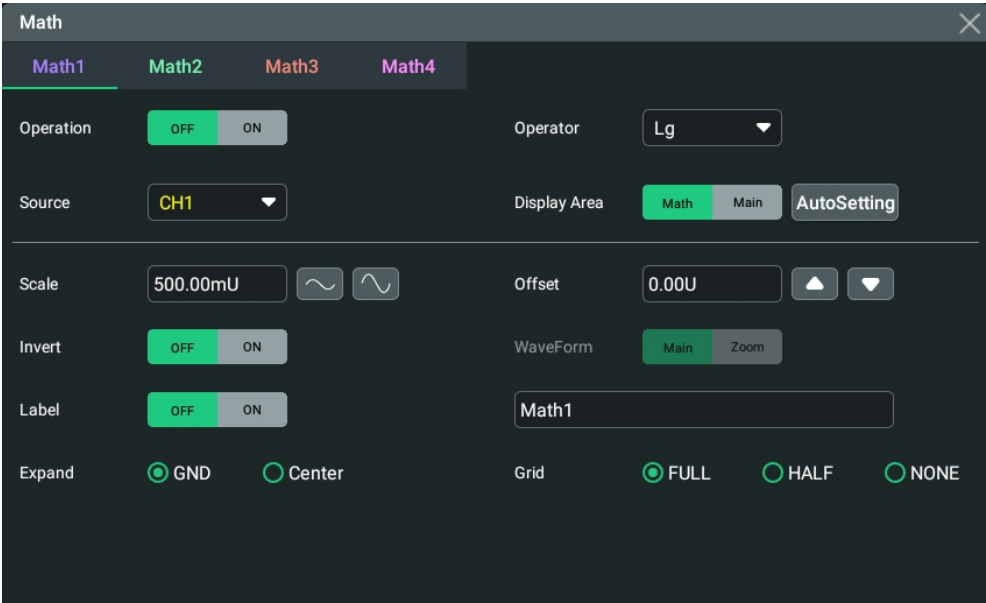

Figure 9.5 Function Operation Menu

Operation Result Display Window

Click or tap the ON/OFF tab for the **Operation** menu to enable or disable the display of the operation result window. The source and the vertical scale parameters are displayed at the top of the window, as shown in the figure below.

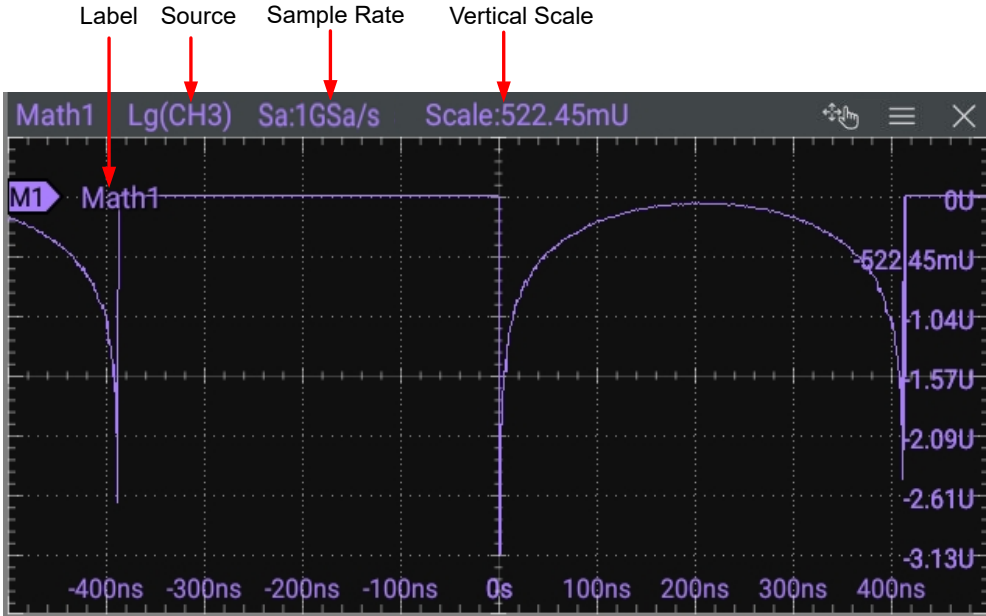

Figure 9.6 Operation Result Display Window

Source

Click or tap the drop-down button of **Source** to select CH1~CH4, Ref1-Ref10. When a source channel is selected, the selected channel automatically switches to the ON state.

Auto Set

Click or tap **AutoSetting** to adjust the vertical scale and the offset of the operation results to the optimal value according to the current configuration, so as to better to observe.

Scale

Scale is used to set the vertical scale of the operation result. For setting methods, refer to descriptions in *To Adjust the Vertical Scale*.

Offset

Offset is used to set the vertical offset of the operation result. For setting methods, refer to descriptions in *To Adjust the Vertical Offset*.

Invert

Invert is used to enable or disable the inverted display function of the waveform. For setting methods, refer to descriptions in *Waveform Invert*.

Waveform

This oscilloscope supports Main and Zoom. By default, it is Main.

- **MAIN:** indicates that the measurement range is within the main time base region.
- **ZOOM:** indicates that the measurement range is within the zoomed time base region.

When you select "Zoom", you need to enable *Delayed Sweep* in *To Set the Horizontal System*.

Label

Label is used to set the label for the math operation results. For setting methods, refer to descriptions in *Channel Label*.

Grid

For setting methods, refer to the descriptions in *To Set the Screen Grid*.

Expand

The oscilloscope supports two vertical expansion modes: GND and Center. By default, it is "GND".

- **GND:** when the vertical scale is changed, the math operation waveform will be expanded or compressed around the signal ground level position.
- **Center:** when the vertical scale is changed, the math operation waveform will be expanded or compressed around the screen center.

Display Area

Click or tap to select "Math" or "Main" under **Display Area**.

- **Math:** when you select "Math", the waveforms of math operation are displayed in the math operation window.
- **Main:** when you select "Main", the waveforms of math operation are displayed in the main interface window.

Parameter Setting

- When the operator is "Intg", click or tap the input field for the **Offset** menu item and use the pop-up numeric keypad to set the DC offset calibration factor of the input signal.
- When the operator is "Diff", click or tap the input field for the **Smooth** menu item and use the pop-up numeric keypad to set the number of smooth times for the differential operation.

9.3 FFT Operation

FFT (Fast Fourier Transform) is used to transform time-domain signals to frequency-domain components (frequency spectrum). This oscilloscope provides FFT operation function which enables you to observe the time-domain waveform and spectrum of the signal at the same time. FFT operation can facilitate the following works:

- Measure harmonic components and distortion in the system;
- Display the characteristics of the noise in DC power;
- Analyze vibration.

In the **Math** menu, click or tap the drop-down button of **Operator** to select **FFT** to go to the menu shown in *Figure 9.7*. Then configure the parameters of FFT.

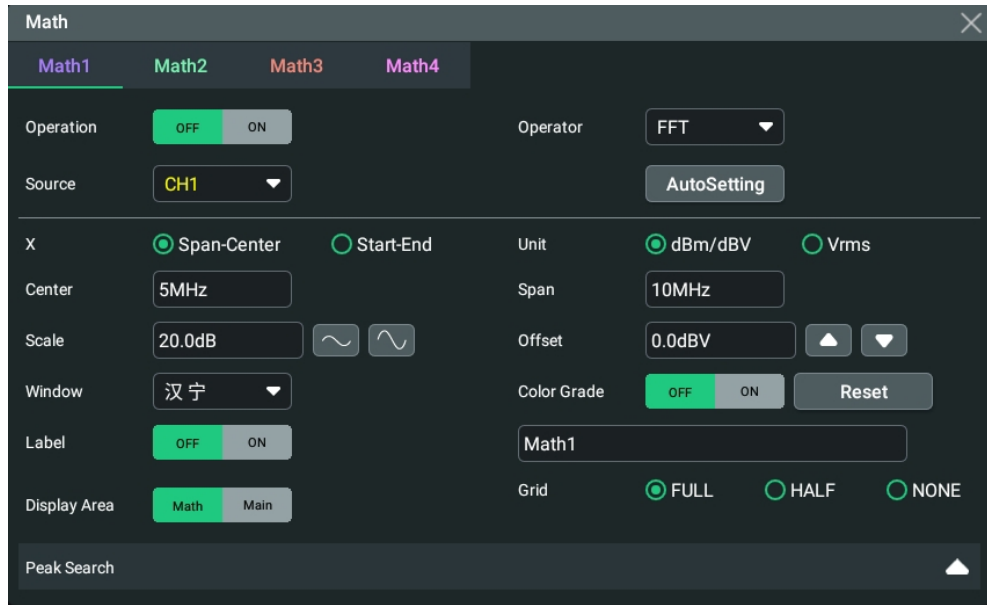

Figure 9.7 FFT Operation Menu

Operation

Click or tap the on/off tab for the **Operation** menu to enable or disable the FFT operation result window. The parameters such as center frequency, frequency range, and resolution are displayed at the top of the window, as shown in the figure below. Of which, FFT resolution is the quotient of the sample rate and the number of FFT points. If the number of FFT points is a fixed value (65535 at most), then the lower the sample rate, the higher the resolution.

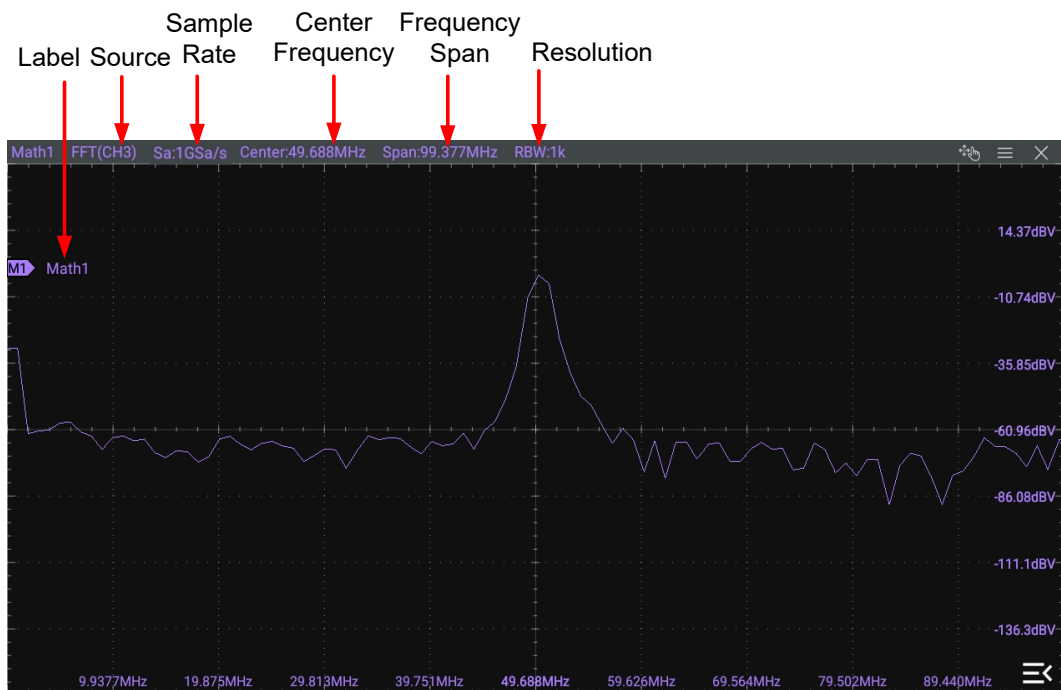

Figure 9.8 FFT Operation Window

Source

Click or tap the drop-down button for the **Source** to select CH1~CH4. When a source channel is selected, the selected channel automatically switches to the ON state.

Auto Set

Click or tap **AutoSetting** to adjust the vertical scale and the offset of the operation results to the optimal value according to the current configuration, so as to better to observe.

Frequency Range

In the **X** menu, select "Span-Center" (frequency range to center frequency) or "Start-End" (start frequency to stop frequency) as a frequency range mode.

- **Span-Center (frequency range to center frequency):** the frequency range refers to the screen width, and you can divide the frequency range by 10 to obtain the frequency per division.

Click or tap the input field of **Center** to set the frequency of the frequency-domain waveform relative to the horizontal center of the screen. Click or tap the input field of **Span** to set the frequency range of the frequency-domain waveform.

- **Start-End:** Start frequency refers to the frequency at the left side of the screen. Click or tap the input field of **Start** to set the start frequency of the frequency-domain waveform with the pop-up numeric keypad. Stop frequency refers to the frequency at the right side of the screen. Click or tap the input field of **End** to set the stop frequency of the frequency-domain waveform with the pop-up numeric keypad.

Vertical Scale/Offset

Selects **dBm/dBV** or **Vrms** as the unit for **Scale** and **Offset**. When "dBm/dBV" is selected, the **Scale** unit is automatically set to "dB", the **Offset** unit is automatically set to "dBm", you can increase or decrease the scale and offset value by clicking or tapping the icons next to the input field; When "Vrms" is selected, the **Scale** unit and the **Offset** unit are automatically set to "Vrms", you can increase or decrease the scale and offset value by clicking or tapping the icons next to the input field.

For setting methods of **Scale**, refer to the descriptions in *To Adjust the Vertical Scale*. For setting methods of **Offset**, refer to the descriptions in *To Adjust the Vertical Offset*.

Window Function

Spectral leakage can be considerably decreased when a window function is used. The oscilloscope provides 6 FFT window functions which have different characteristics and are applicable to measure different waveforms. You need to select the window

function according to the characteristics of the waveform to be measured. Click or tap the drop-down button of **Window** to select the desired window function.

Table 9.1 Window Function

Window Function	Characteristics	Waveforms Applicable to the Window Function
Rectangular	Best frequency resolution Poorest amplitude resolution Similar to the situation when no window is applied.	Transient or short pulse, the signal levels before and after the multiplication are basically the same Sine waveforms with the same amplitudes and rather similar frequencies Wide band random noise with relatively slow change of waveform spectrum
Blackman-Harris	Best amplitude resolution Poorest frequency resolution	Single frequency signal, searching for higher order harmonics
Hanning	Better frequency resolution and poorer amplitude resolution compared with Rectangular	Sine, periodic, and narrow band random noise
Hamming	A little bit better frequency resolution than Hanning	Transient or short pulse, the signal levels before and after the multiplication are rather different
Flattop	Measure the signals accurately	Measure the signal that has no accurate reference and requires an accurate measurement
Triangle	Better frequency resolution	Measure the narrow band signal and that has strong noise interference

Color Grade

Click or tap the ON/OFF button for the **Color Grade** item to enable/disable the color grade display of FFT operation results. When enabled, different colors are displayed on the screen to indicate the times of data acquisition or acquisition probability. Click or tap the **Reset** button for the Color Grade menu to clear the color grade display and display the color grade again.

Grid

For setting methods, refer to the descriptions in *To Set the Screen Grid*.

Display Area

Click or tap to select "Math" or "Main" under **Display Area**.

- **Math:** when you select "Math", the waveforms of math operation are displayed in the math operation window.
- **Main:** when you select "Main", the waveforms of math operation are displayed in the main interface window.

Peak Search

Click or tap the icon  at the right side of **Peak Search** to enter the peak search menu, as shown in the figure below.

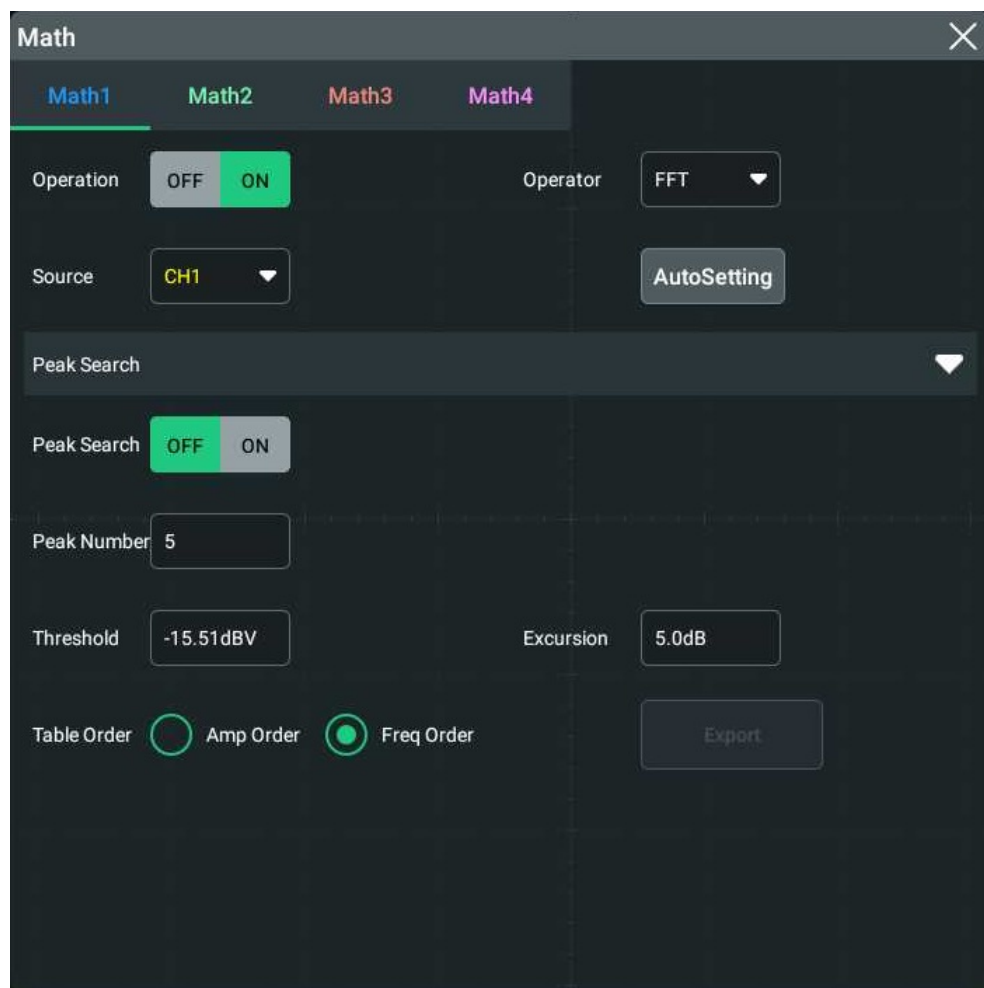



Figure 9.9 Peak Search

- **Peak Search ON/OFF:** click or tap the ON/OFF button for the **Peak Search** menu to enable or disable the display of the peak search window. By default, it is OFF.

- **Peak Number:** click or tap the input field for the **Peak Number** menu item and use the pop-up numeric keypad to set the number of peaks. Its range is from 1 to 15. Its default value is 5.
- **Threshold:** click or tap the input field for the **Threshold** menu item to set the threshold of the peak with the pop-up numeric keypad. The range of the threshold is related to the current FFT scale and offset.
- **Excursion:** click or tap the input field for the **Excursion** menu item to set the excursion of the peak. The min. value of Excursion is 0 and its unit is dB.
- **Table Order:** click or tap to select **Amp Order** or **Freq Order** as the sorting mode under the **Table Order** menu. By default, it is "Amp Order".

Click or tap **Export**, then the save setting interface is displayed. You can export the peak search results to the internal memory or the external USB storage device in CSV format. For detailed saving operation, refer to *To Save a File* and *Disk Management*.

Clicking or tapping the icon  at the right side of **Peak Search** can close the the peak search menu.

9.4 Logic Operation

In the **Math** menu, click or tap **Operator** to select the desired math operation. The logic operation supported by this oscilloscope include $A \& B$, $A || B$, $A \wedge B$, and $\neg A$. After selecting the desired logic operation from the drop-down list of **Operator**, you can configure its settings for the selected logic operation type.

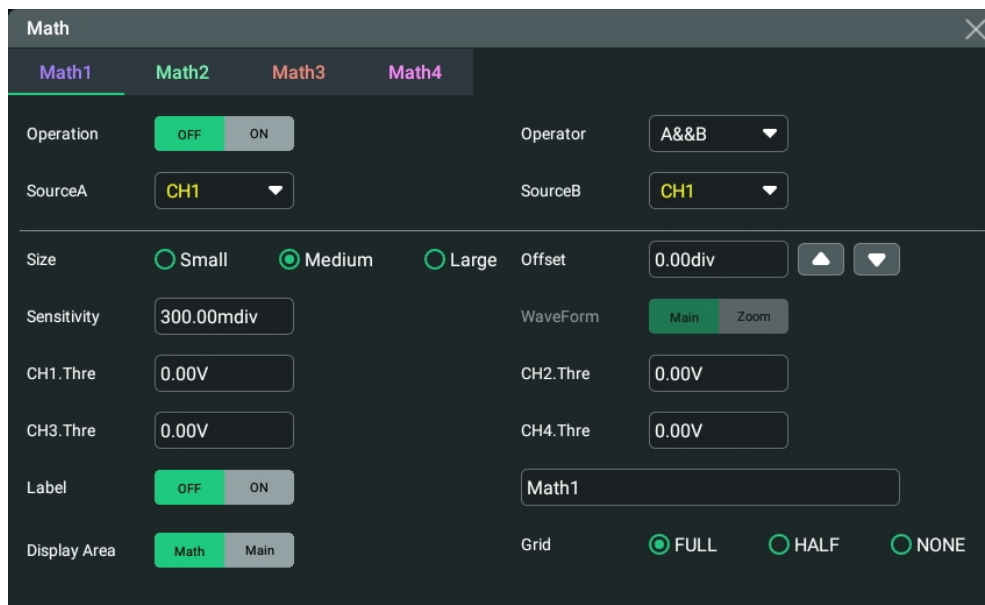

Figure 9.10 Logic Operation Menu

- **A&&B:** Performs logic "AND" operation on the waveform voltage values of the specified sources point by point and displays the results. In operation, when the voltage value of the source channel is greater than the threshold of the corresponding channel, it is regarded as logic "1"; otherwise it is logic "0". The results of logic AND operation of two binary bits are shown in *Table 9.2 Logic Operation*.
- **A||B:** Performs logic "OR" operation on the waveform voltage values of the specified sources point by point and displays the results. In operation, when the voltage value of the source channel is greater than the threshold of the corresponding channel, it is regarded as logic "1"; otherwise it is logic "0". The results of logic OR operation of two binary bits are shown in *Table 9.2 Logic Operation*.
- **A^B:** Performs logic "XOR" operation on the waveform voltage values of the specified sources point by point and displays the results. In operation, when the voltage value of the source channel is greater than the threshold of the corresponding channel, it is regarded as logic "1"; otherwise it is logic "0". The results of logic XOR operation of two binary bits are shown in *Table 9.2 Logic Operation*.
- **!A:** Performs logic "NOT" operation on the waveform voltage values of the specified sources point by point and displays the results. In operation, when the voltage value of the source channel is greater than the threshold of the corresponding channel, it is regarded as logic "1"; otherwise it is logic "0". The results of logic "NOT" operation of one binary bit are shown in *Table 9.2 Logic Operation*.

Table 9.2 Logic Operation

A	B	A&&B	A B	A^B	!A
0	0	0	0	0	1
0	1	0	1	1	1
1	0	0	1	1	0
1	1	1	1	0	0

Operation Result Display Window

Click or tap the ON/OFF tab for the **Operation** menu to enable or disable the display of the operation result window. The source and the waveform sizes parameters are displayed at the top of the window, as shown in the figure below.

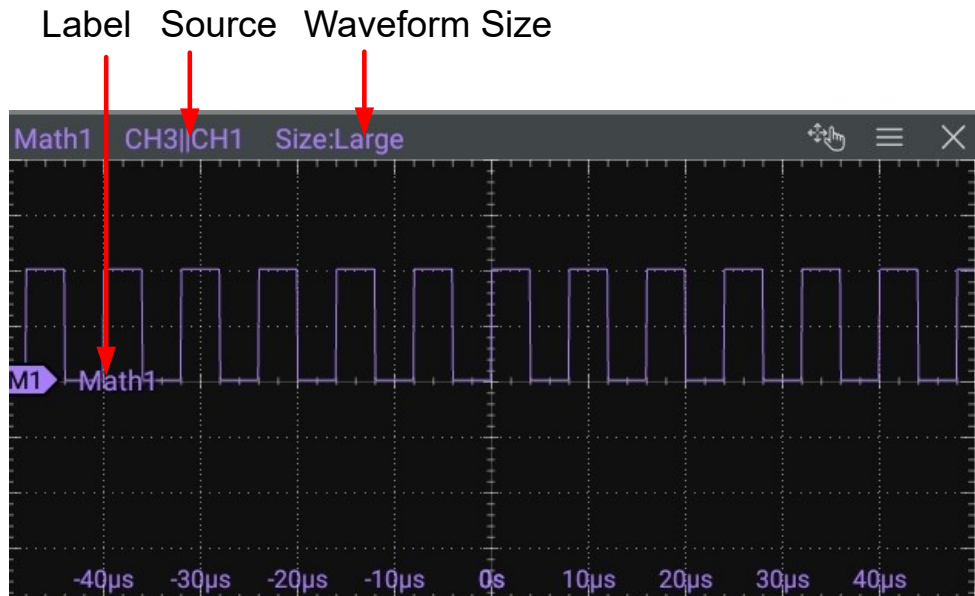

Figure 9.11 Operation Result Display Window

Source

Click or tap the drop-down button of **SourceA** or **SourceB** to select CH1~CH4, . When a source channel is selected, the selected channel automatically switches to the ON state.

Wave Size

Click or tap to select "Small", "Medium", or "Large" as the the waveform display mode.



Offset

Offset is used to set the vertical offset of the operation result. For setting methods, refer to descriptions in *To Adjust the Vertical Offset*.

Sensitivity

Sets the sensitivity of the digital signal converted from the analog signal on the source. Click or tap the input field of this menu to set the sensitivity with the pop-up numeric keypad. For detailed operations, refer to the descriptions in *Parameter Setting Method*.

Waveform

This oscilloscope supports Main and Zoom. By default, it is Main.

- **MAIN:** indicates that the measurement range is within the main time base region.
- **ZOOM:** indicates that the measurement range is within the zoomed time base region.

When you select "Zoom", you need to enable *Delayed Sweep* in *To Set the Horizontal System*.

Threshold

Click or tap the input field for the threshold menu of the specified channel and use the pop-up numeric keypad to set the threshold. For detailed operations, refer to the descriptions in *Parameter Setting Method*.



Label

Label is used to set the label for the math operation results. For setting methods, refer to descriptions in *Channel Label*.

Display Area

Click or tap to select "Math" or "Main" under **Display Area**.

- **Math:** when you select "Math", the waveforms of math operation are displayed in the math operation window.
- **Main:** when you select "Main", the waveforms of math operation are displayed in the main interface window.

Grid

For setting methods, refer to the descriptions in *To Set the Screen Grid*.

9.5 Digital Filter

In the **Math** menu, click or tap **Operator** to select the desired math operation. The digital filter supported by this oscilloscope includes: low-pass filter, high-pass filter, band-pass filter, and band-stop filter.

- **LowPass:** only allows the signals whose frequencies are lower than the current upper limit frequency to pass.

- **HighPass:** only allows the signals whose frequencies are higher than the current lower limit frequency to pass.
- **BandPass:** only allows the signals whose frequencies are higher than the current lower limit frequency and lower than the current upper limit frequency to pass.
- **BandStop:** only allows the signals whose frequencies are lower than the current lower limit frequency or higher than the current upper limit frequency to pass.

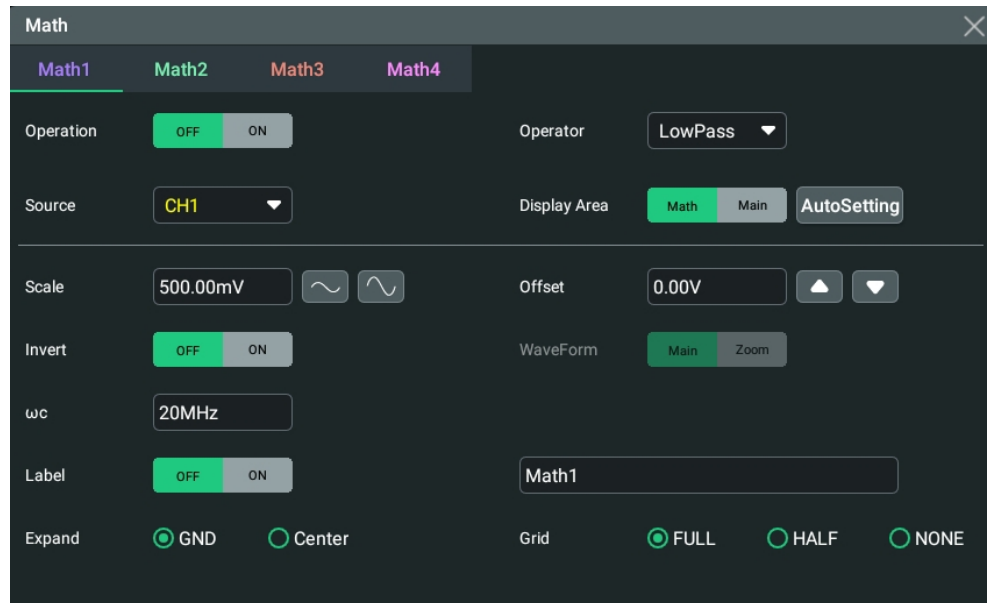

Figure 9.12 Digital Filter Menu

Operation Result Display Window

Click or tap the on/off tab for the **Operation** menu to enable or disable the display of the operation result window. The source and the vertical scale parameters are displayed at the top of the window, as shown in the figure below.

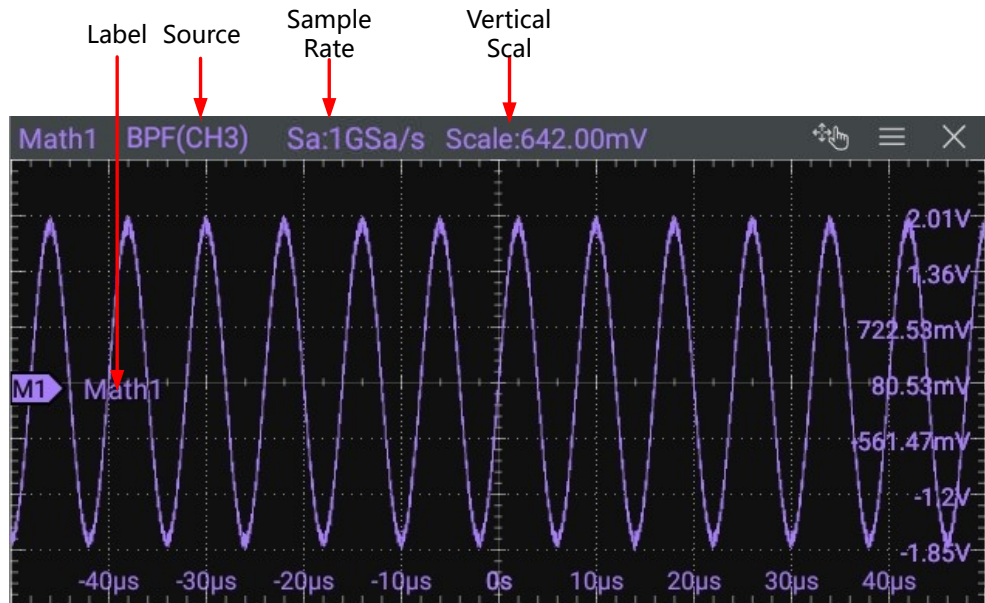

Figure 9.13 Operation Result Display Window

Source

Click or tap the drop-down button of **Source** to select CH1~CH4, Ref1-Ref10. When a source channel is selected, the selected channel automatically switches to the ON state.

Display Area

Click or tap to select "Math" or "Main" under **Display Area**.

- **Math:** when you select "Math", the waveforms of math operation are displayed in the math operation window.
- **Main:** when you select "Main", the waveforms of math operation are displayed in the main interface window.

Auto Set

Click or tap **AutoSetting** to adjust the vertical scale and the offset of the operation results to the optimal value according to the current configuration, so as to better to observe.

Scale

Scale is used to set the vertical scale of the operation result. For setting methods, refer to descriptions in *To Adjust the Vertical Scale*.

Offset

Offset is used to set the vertical offset of the operation result. For setting methods, refer to descriptions in *To Adjust the Vertical Offset*.

Invert

Invert is used to enable or disable the inverted display function of the waveform. For setting methods, refer to descriptions in [Waveform Invert](#).

Waveform

This oscilloscope supports Main and Zoom. By default, it is Main.

- **MAIN:** indicates that the measurement range is within the main time base region.
- **ZOOM:** indicates that the measurement range is within the zoomed time base region.

When you select "Zoom", you need to enable [Delayed Sweep](#) in [To Set the Horizontal System](#).

Frequency Limit

- **LowPass:** click or tap the input field of **wc** and use the pop-up numeric keypad to set the upper limit frequency.
- **HighPass:** click or tap the input field of **wc** and use the pop-up numeric keypad to set the lower limit frequency.
- **BandPass:** click or tap the input field of **wc1** and use the pop-up numeric keypad to set the lower limit frequency. Click or tap the input field of **wc2** and use the pop-up numeric keypad to set the upper limit frequency.
- **BandStop:** click or tap the input field of **wc1** and use the pop-up numeric keypad to set the lower limit frequency. Click or tap the input field of **wc2** and use the pop-up numeric keypad to set the upper limit frequency.

The settable ranges of the upper and lower limit frequencies are related to the Math sample rate (displayed at the bottom of the screen when the Math function is enabled). The sample rate of the analog channel or the changes of the memory depth can affect the Math sample rate.

Label

Label is used to set the label for the math operation results. For setting methods, refer to descriptions in [Channel Label](#).

Expand

The oscilloscope supports two vertical expansion modes: GND (default) and Center.

- **GND:** When the vertical scale is changed, the math operation waveform will expand or compress about the ground level of the signal.

- **Center:** When the vertical scale is changed, the math operation waveform will expand or compress about the center of the display.

Grid

For setting methods, refer to the descriptions in *To Set the Screen Grid*.

10 Measure

To enter the **Measure** menu, perform any of the following operations:

- Click or tap the function navigation icon  at the lower-left corner of the screen, and then select **Measure** to enter the "Measure" menu.
- Tap the **Measure** icon on the secondary screen at the right side of the screen to enter the "Measure" menu.
- Click or tap the **Measure** icon at the upper right part of the screen enter the "Measure" menu.
- In *To Set the Vertical System*, click or tap **Measure** to enter the measurement setting menu.

10.1 Measurement Parameter

This oscilloscope allows you to set the measurement source, enable or disable the all measurement function, the statistical function, and etc. You can make quick measurements for many waveform parameters. The measurement results will be displayed at the right section of the screen under the **Result** list.

TIP



If there is no signal input for the current source or the measurement result is not within the valid range (too large or too small), then the measurement results are invalid, and "*****" is displayed on the screen. Please re-input the signal or set the signal.

10.1.1 Time Parameters

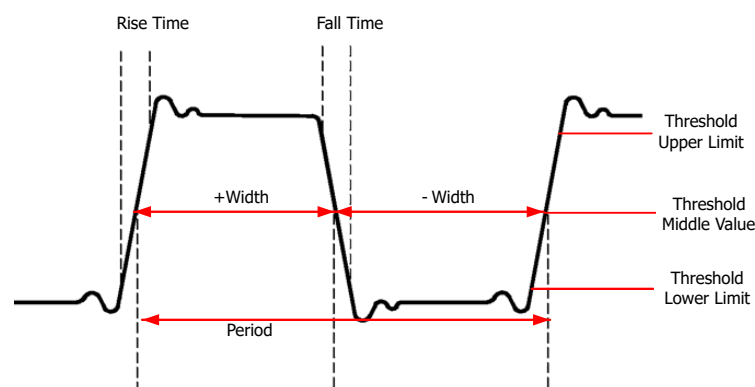

Figure 10.1 Time Parameters

- **Period:** defined as the time between the middle threshold points of two consecutive, like-polarity edges.

- **Frequency:** defined as the reciprocal of period.
- **Rise Time:** indicates the time for the signal amplitude to rise from the threshold lower limit to the threshold upper limit.
- **Fall Time:** indicates the time for the signal amplitude to rise from the threshold upper limit to the threshold lower limit.
- **+Width:** indicates the time between the threshold middle value of a rising edge to the threshold middle value of the next falling edge.
- **-Width:** indicates the time between the threshold middle value of a falling edge to the threshold middle value of the next rising edge.
- **+Duty:** indicates the ratio of the positive pulse width to the period.
- **-Duty:** indicates the ratio of the negative pulse width to the period.
- **Tvmax:** indicates the time that corresponds to the maximum value of the waveform (Vmax).
- **Tvmin:** indicates the time that corresponds to the minimum value of the waveform (Vmin).

The default values for threshold upper limit, threshold middle value, and threshold low limit are 90%, 50%, and 10%, respectively.

10.1.2 Count Values

The default values for threshold upper limit and threshold low limit are 90% and 10%, respectively.

Positive Pulse Count

The number of positive pulses that rise from under the threshold lower limit to above the threshold upper limit.

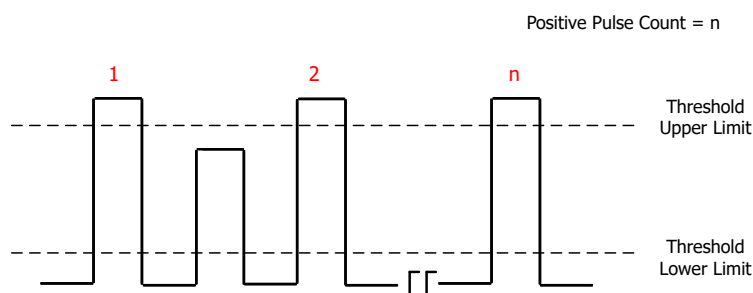

Negative Pulse Count

The number of negative pulses that fall from above the threshold upper limit to below the threshold lower limit.

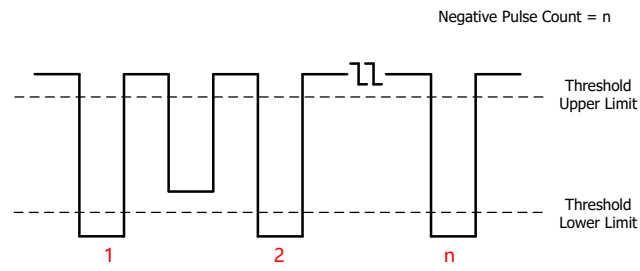

Rising Edge Count

The number of rising edges that rise from under the threshold lower limit to above the threshold upper limit.

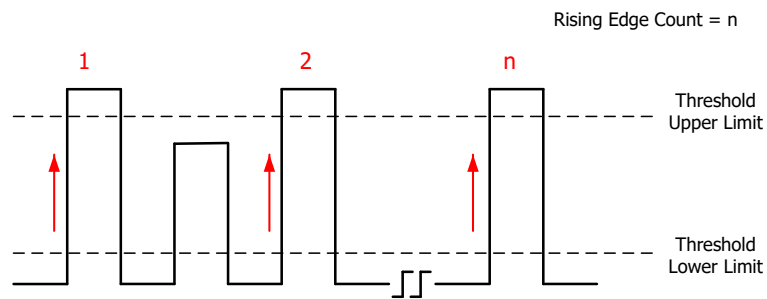

Falling Edge Count

The number of falling edges that fall from above the threshold upper limit to below the threshold lower limit.

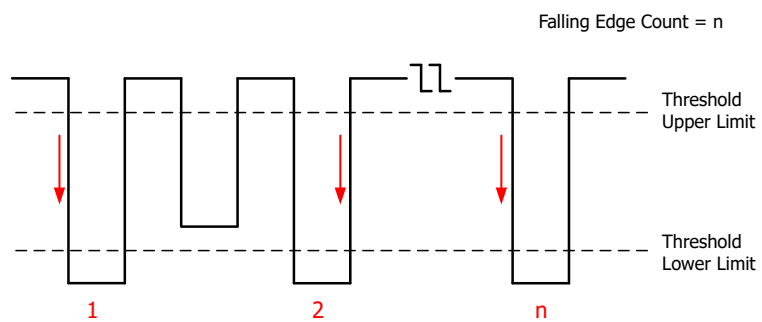

10.1.3 Delay and Phase Parameters

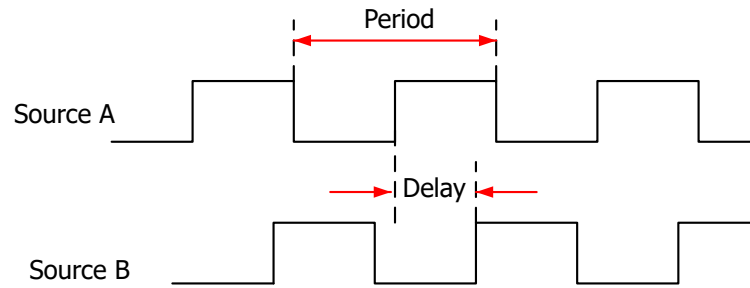

Figure 10.2 Delay and Phase Parameters

- 1. Delay(r-r):** indicates the time difference between the threshold middle values of the rising edge of Source A and that of Source B. Negative delay indicates that the rising edge of Source A occurred after that of Source B.
- 2. Delay(f-f):** indicates the time difference between the threshold middle values of the falling edge of Source A and that of Source B. Negative delay indicates that the falling edge of Source A occurred after that of Source B.
- 3. Delay(r-f):** indicates the time difference between the threshold middle values of the rising edge of Source A and the falling edge of Source B. Negative delay indicates that the rising edge of Source A occurred after the falling edge of Source B.
- 4. Delay(f-r):** indicates the time difference between the threshold middle values of the falling edge of Source A and the rising edge of Source B. Negative delay indicates that the falling edge of Source A occurred after the rising edge of Source B.
- 5. Phase(r-r):** indicates the phase deviation between the threshold middle values of the rising edge of Source A and that of Source B. The phase formula is as follows:

$$PhaseA_{RB_R} = \frac{DelayA_{RB_R}}{Period_{sourceA}} \times 360^\circ$$

Wherein, $PhaseA_{RB_R}$ represents Phase(r-r), $DelayA_{RB_R}$ represents Delay(r-r), and $Period_{sourceA}$ represents period of Source A.

- 6. Phase(f-f):** indicates the phase deviation between the threshold middle values of the falling edge of Source A and that of Source B. The phase formula is as follows:

$$PhaseA_{FB_F} = \frac{DelayA_{FB_F}}{Period_{sourceA}} \times 360^\circ$$

Wherein, $PhaseA_F B_F$ represents Phase(f-f), $DelayA_F B_F$ represents Delay(r-r), and $Period_{sourceA}$ represents period of Source A.

- 7. Phase(r-f):** indicates the phase deviation between the threshold middle values of the rising edge of Source A and the falling edge of Source B. The phase formula is as follows:

$$PhaseA_R B_F = \frac{DelayA_R B_F}{Period_{sourceA}} \times 360^\circ$$

Wherein, $PhaseA_R B_F$ represents Phase(r-f), $DelayA_R B_F$ represents Delay(r-f), and $Period_{sourceA}$ represents period of Source A.

- 8. Phase(f-r):** indicates the phase deviation between the threshold middle values of the falling edge of Source A and the rising edge of Source B. The phase formula is as follows:

$$PhaseA_F B_R = \frac{DelayA_F B_R}{Period_{sourceA}} \times 360^\circ$$

Wherein, $PhaseA_F B_R$ represents Phase(f-r), $DelayA_F B_R$ represents Delay(f-r), and $Period_{sourceA}$ represents period of Source A.



TIP

- Source A and Source B can be any channel among CH1~CH4 and Math1~Math4.
- The default threshold middle value is 50%.

10.1.4 Voltage Parameters

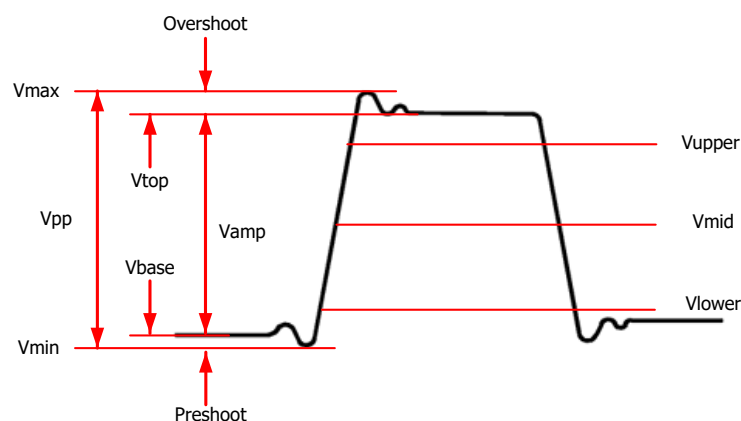

Figure 10.3 Voltage Parameters

- 1. Vmax:** indicates the voltage value from the highest point of the waveform to the GND.

2. **Vmin:** indicates the voltage value from the lowest point of the waveform to the GND.
3. **Vpp:** the voltage value from the highest point to the lowest point of the waveform.
4. **Vtop:** indicates the voltage value from the flat top of the waveform to the GND.
5. **Vbase:** indicates the voltage value from the flat base of the waveform to the GND.
6. **Vamp:** indicates the voltage value from the top of the waveform to the base of the waveform.
7. **Vupper:** indicates the actual voltage value that corresponds to the threshold maximum value.
8. **Vmid:** indicates the actual voltage value that corresponds to the threshold middle value.
9. **Vlower:** indicates the actual voltage value that corresponds to the threshold minimum value.
10. **Vavg:** indicates the arithmetic average value on the whole waveform or in the gating area. The formula is shown as follows:

$$Average = \frac{\sum_{i=1}^n x_i}{n}$$

Wherein, x_{ith} is the amplitude of the ith point, and n is the number of points being measured.

11. **VRMS:** indicates the root mean square value on the whole waveform or in the gating area. The formula is as follows:

$$RMS = \sqrt{\frac{\sum_{i=1}^n x_i^2}{n}}$$

Wherein, x_{ith} is the measurement result of the ith point, and n is the number of points being measured.

12. **Per.VRMS:** indicates the root mean square value within a period. The formula is as shown above.
13. **Overshoot:** indicates the ratio of the difference between the maximum value and the top value of the waveform to the amplitude value.
14. **Preshoot:** indicates the ratio of the difference between the minimum value and the base value of the waveform to the amplitude value.
15. **AC RMS:** indicates the root-mean-square value of the waveforms, with the DC component removed. The formula is shown as follows:

$$\text{Std.Dev} = \sqrt{\frac{\sum_{i=1}^n (x_i - \text{Average})^2}{n}}$$

Wherein, x_{ith} is the amplitude of the ith point, *Average* is the waveform average value, and n is the number of points being measured.

10.1.5 Other Parameters

- **Positive Slew Rate:** On the rising edge, first calculate the difference between the high value and the low value, then use the difference to divide the corresponding time value to obtain the positive slew rate.
- **Negative Slew Rate:** On the falling edge, first calculate the difference between the low value and the high value, then use the difference to divide the corresponding time value to obtain the negative slew rate.
- **Area:** indicates the area of the whole waveform within the screen. The unit is V*s. The area of the waveform above the zero reference (namely the vertical offset) is positive, and the area of the waveform below the zero reference is negative. The area measured is the algebraic sum of the area of the whole waveform within the screen.
- **Period Area:** indicates the area of the first period of waveform on the screen. The unit is V*s. The area of the waveform above the zero reference (namely the vertical offset) is positive, and the area of the waveform below the zero reference is negative. The area measured is the algebraic sum of the whole period area.

10.2 To Select the Measurement Item

In the **Measure** menu, click or tap **Horizontal**, **Vertical**, or **Other** to go to the desired menu. You can also slide to select the measurement item to enter the corresponding interface, as shown in *Figure 10.4*, *Figure 10.5*, and *Figure 10.6*.

- **Vertical:** Vmax, Vmin, Vpp, Vtop, Vbase, Vamp, Vupper, Vmid, Vlower, Vavg, VRMS, Per. VRMS, AC.RMS, Overshoot, Preshoot, Area, and Period Area.

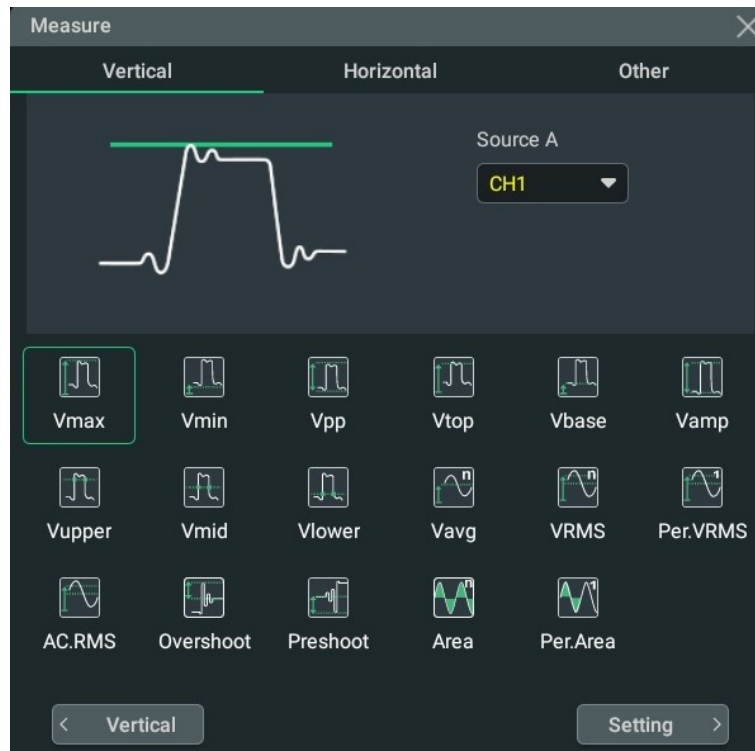

Figure 10.4 Vertical Measurement Items

- Horizontal:** Period, Frequency, Rise Time, Fall Time, +Width, -Width, +Duty, -Duty, Positive Pulse Count, Negative Pulse Count, Rising Edge Count, Falling Edge Count, T_{vmax}, T_{vmin}, +Slew Rate, and -Slew Rate.

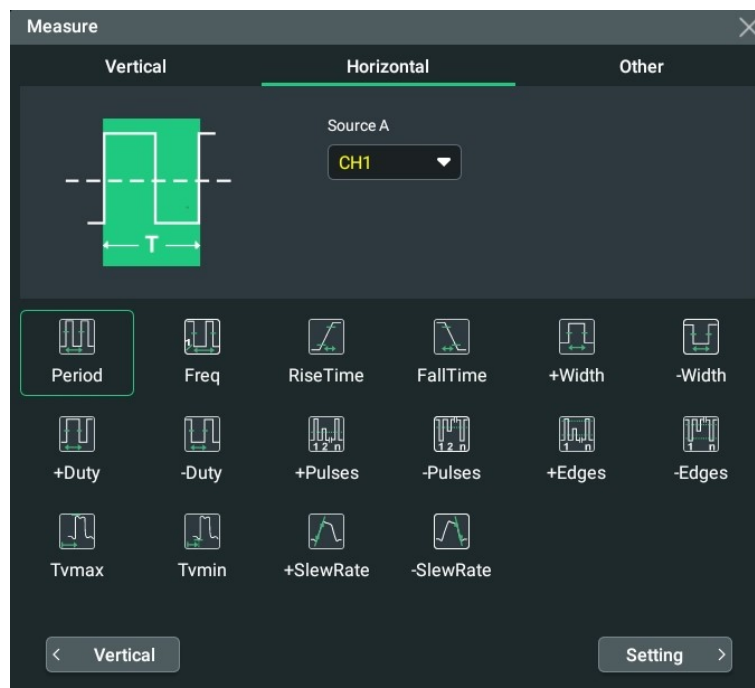

Figure 10.5 Horizontal Measurement Items

Click or tap the drop-down button of **Source A** to select the desired source. The available sources are CH1~CH4, Math1~Math4, and Ref1~Ref10.

- **Other:** Delay (r-r), Delay (r-f), Delay (f-r), Delay (f-f), Phase (r-r), Phase (r-f), Phase(f-r), and Phase (f-f).

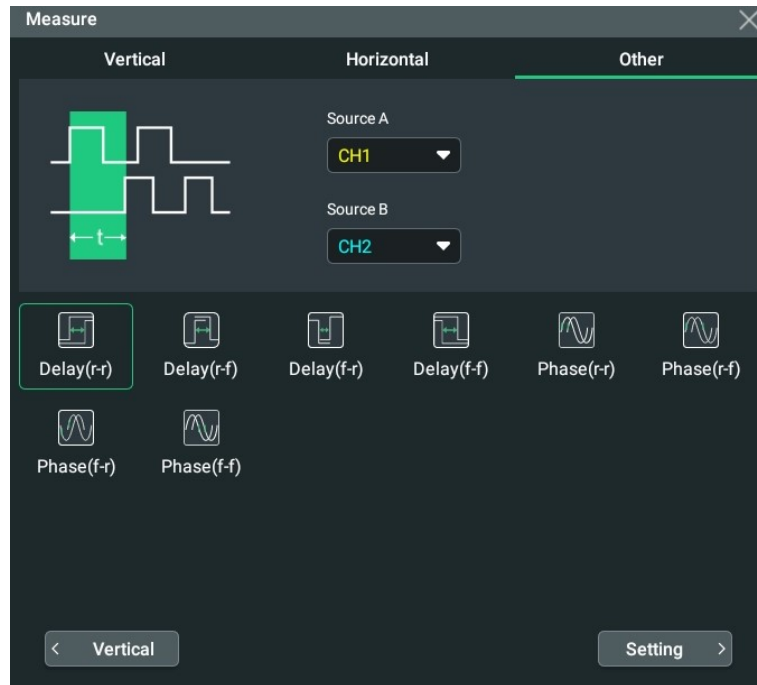

Figure 10.6 Other Measurement Items

Click or tap the drop-down button of **Source A** or Source B to select the desired source. The available sources are CH1~CH4, Math1~Math4, and Ref1~Ref10.

10.3 Measurement Settings

In the **Measure** menu, click or tap the **Setting** button to enter the measurement setting menu.

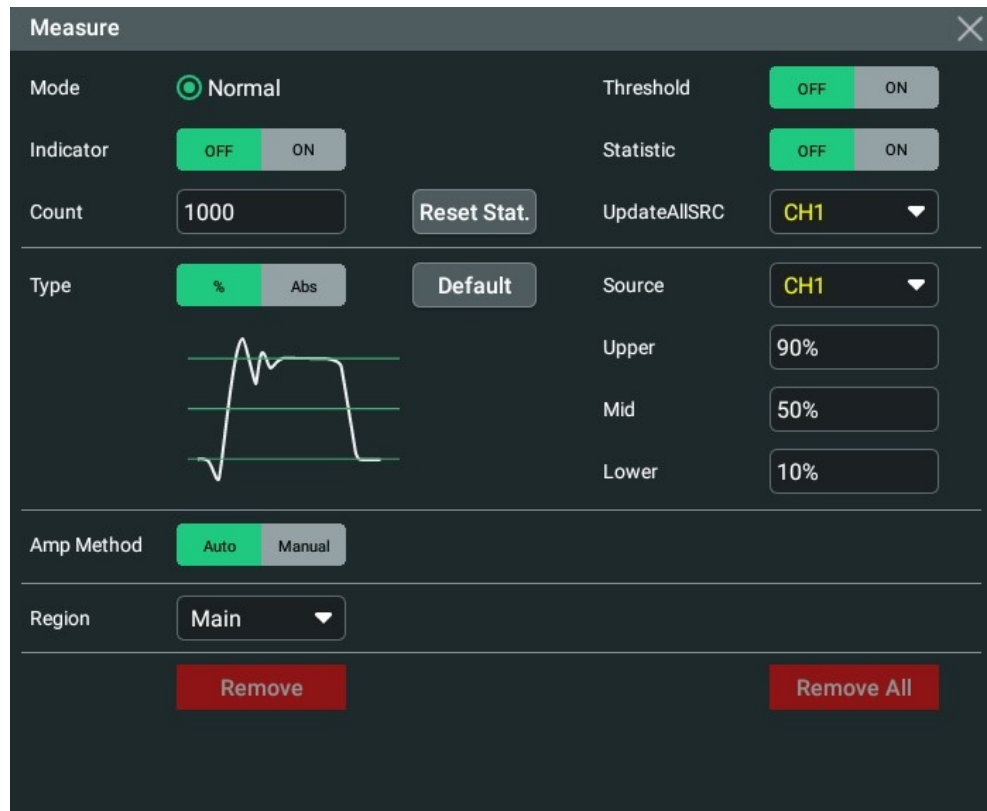

Figure 10.7 Measurement Settings

Measurement Mode

By default, the measurement mode is Normal. In Normal mode, the instrument can execute measurement of up to 1 Mpts.

Threshold

In the **Measure** setting menu, click or tap **ON** or **OFF** for the **Threshold** menu item to enable or disable the display of the threshold.

NOTE

When **Threshold** is enabled, **Indicator** is enabled synchronously.

If the threshold is enabled, the upper threshold, middle threshold, and lower threshold of the waveforms are displayed at the crossing point of the cursor and the waveforms on the screen.

Indicator

In the **Measure** setting menu, click or tap **ON** or **OFF** for the **Indicator** menu item to enable or disable the indicator.

NOTE

When **Indicator** is enabled, **Threshold** is enabled synchronously.

If the indicator is enabled, one or multiple cursors will be displayed on the screen. Before enabling the indicator, you need to at least enable one auto measurement parameter and the number of cursors will change with the measurement parameter enabled.

Measurement Threshold

- First click or tap **%** or **Abs** as the display type.
- Click or tap the drop-down button of **Source** to select the desired channel (CH1~CH4 or Math1~Math4).
- Click or tap the input field of **Upper** and use the pop-up numeric keypad to set the upper limit of the measurement. When the upper limit is set to be smaller than or equal to the current middle value, a prompt message "Set at lower limit" is displayed. Then, the oscilloscope will automatically adjust the upper limit and make it greater than the middle value. By default, it is 90%. The default absolute value varies with the vertical setting of the channel.
- Click or tap the input field of **Mid** and use the pop-up numeric keypad to set the middle value of the measurement. The middle value is limited by the settings of the upper limit and lower limit. By default, it is 50%. The default absolute value varies with the vertical setting of the channel.
- Click or tap the input field of **Lower** and use the pop-up numeric keypad to set the lower limit of the measurement. When the lower limit is set to be greater than or equal to the current middle value, a prompt message "Set at upper limit" is displayed. Then, the oscilloscope will automatically adjust the lower limit and make it smaller than the middle value. By default, it is 10%. The default absolute value varies with the vertical setting of the channel.
- Click or tap **Default**, and then the upper value, middle value, and lower value will be restored to the defaults.

TIP

Modifying the threshold will affect the measurement results of time, delay, and phase parameters.

Measurement Range

Click or tap the drop-down button of **Region** to select "Main", "Zoom", or "Cursor".

- **Main:** indicates that the measurement range is within the main time base region.
- **Zoom:** indicates that the measurement range is within the zoomed time base region.
- **Cursor:** when you select it and **CursorAB** is set to ON, then two cursors will be displayed on the screen. At this time, click or tap the input field of **CursorA** and **CursorB** respectively and use the pop-up numeric keypad to modify the cursor position and determine the measurement range.

**TIP**

Only when you enable the delayed sweep function first, can "Zoom" be enabled.

Amplitude Measurement Method

Click or tap **Auto** or **Manual** as the amplitude measurement method, which affects the measurement method for the top and base values. If you select "Manual", set the following parameters:

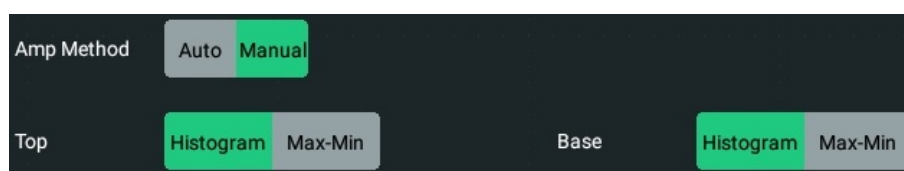

- Under the **Top** menu item, select **Histogram** or **Max-Min** as the top value measurement method.
- Under the **Base** menu item, click or tap **Histogram** or **Max-Min** as the base value measurement method.

**TIP**

If you select "Manual" for the amplitude method, the measurement results of other parameters may be affected.

"Histogram" and "Max-Min" are the internal measurement algorithm for the oscilloscope. The "Histogram" method here is different from the Histogram function of the oscilloscope.



Remove the Measurement Results

Refer to [Remove the Measurement Results](#).

Statistics

Click or tap the ON/OFF button for the **Statistic** item to enable/disable the statistical function. This oscilloscope can make a statistics and display the current values of the multiple parameters, as shown in the figure below.



- Click or tap **Reset Stat.** to clear the history statistics data and makes statistics again.
- Click or tap the input field of **Count** and use the pop-up numeric keypad to set the count value. Its range is from 2 to 100,000. Its default value is 1,000.
- Click or tap the icon  at the lower-right corner of the measurement statistics label to unfold the statistics result to display all the measurement statistics items.
Click or tap the icon  to fold the measurement statistics label.

Update the Measurement Source

Click or tap the drop-down button of **UpdateAllSRC** to select the measurement channels to be updated (CH1~CH4, Math1~Math4, or Ref1~Ref10).

10.4 Remove the Measurement Results

This oscilloscope allows you to remove the measurement results of the parameters.

- In the **Setting** menu, click or tap **Remove** to delete the currently selected measurement item that you' ve added. Each time you click or tap this button, only one item will be deleted. Each time when one measurement item is selected to be removed, the item following the deleted one under the result list will be moved up.
- Click or tap **Remove All** to remove all the displayed measurement items.
- Click or tap to select the measurement item and drag it to the right to delete it quickly.

10.5 Auto Measurement

When the oscilloscope is correctly connected and has detected a valid input signal,

click or tap the function navigation icon  at the lower-left corner of the screen to

select the **Auto** icon to enable the waveform auto setting function and open the auto setting function menu.



- Click or tap the first icon, and then the single period of the signal is displayed automatically on the screen. Meanwhile, the system will make measurements for the "period" and "frequency" of the currently displayed waveforms in a single period. The measurement results are displayed at the right side of the screen under the "Result" list.
- Click or tap the second icon, and then multiple periods of the signal are displayed automatically on the screen. Meanwhile, the system will make measurements for the "period" and "frequency" of the currently displayed waveforms in a multiple periods. The measurement results are displayed at the right side of the screen under the "Result" list.
- Click or tap the third icon, and then one rising edge of the signal is displayed automatically on the screen. Meanwhile, the system will make measurements for the "rise time" of the currently displayed rising edge. The measurement results are displayed at the right side of the screen under the "Result" list. By default, it is intended for the fast edge signal.
- Click or tap the fourth icon, and then one falling edge of the signal is displayed automatically on the screen. Meanwhile, the system will make measurements for the "Fall time" of the currently displayed falling edge. The measurement results are displayed at the right side of the screen under the "Result" list. By default, it is intended for the fast edge signal.
- Click or tap the fifth icon to cancel the auto setting and recovers to the parameter settings prior to pressing the **Auto** key.
- Click or tap the sixth icon to enter the **Auto Config** sub-menu under the **Utility** menu.
 - Click or tap the ON/OFF tab for the **Peak to Peak** menu to enable or disable the peak-peak priority setting. This function is intended for the shifted signal. If there is a large deviation, you can view the signal waveform in priority when you enable the function.
 - Click or tap the ON/OFF tab for the **Live CH** menu to enable or disable test the enabled channel.

If you select "OFF", the system will test the 4 analog channels (CH1-CH4) in sequence. If no signal is found on the channel, then the channel is disabled. If a signal is found on the channel, adjust the channel to an optimal scale to display the signal. If you select "ON", the system will only test the enabled channels.

- Click or tap the ON/OFF tab for the **Overlay** menu to enable or disable the waveform overlay display function. If enabled, waveforms of different channels will be displayed in the same position of the screen. If disabled, waveforms of different channels will be displayed on the screen from top to bottom in sequence.
- Click or tap ON/OFF tab for the **Coupling** menu to enable or disable the coupling hold function. If enabled, after performing the auto measurement operation, the settings for the channel coupling remain unchanged. If disabled, then the channel coupling is, by default, set to "DC".

**TIP**

The waveform auto setting function requires that the frequency of the signal should be greater than or equal to 35 Hz, the amplitude greater than or equal to 5 mV. If not meeting the conditions, the waveform auto setting function may be invalid.

10.6 Cursor Measurement

Cursor measurement can measure the X axis values (e.g Time) and Y axis values (e.g. Voltage) of the selected waveform. Before making cursor measurement, connect the signal to the oscilloscope to acquire stable display. All the parameters supported by the "*Auto Measurement*" function can be measured with cursor measurement. The cursor measurement function provides the following two cursors.

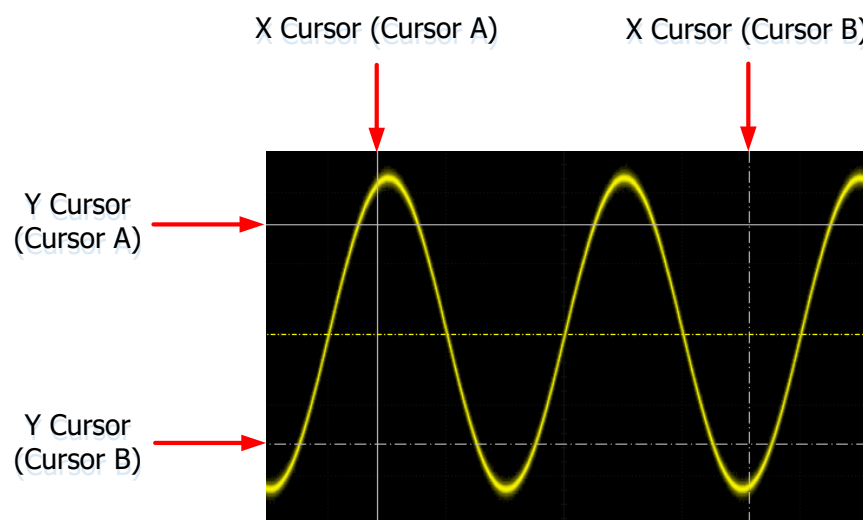



Figure 10.8 Cursor



- **X Cursor**

X cursor is a vertical solid/dotted line that is used to make horizontal adjustments. It can be used to measure time (s) and frequency (Hz).

- Cursor A is a vertical solid line ( is displayed at the bottom of the screen), and Cursor B is a vertical dotted line ( is displayed at the bottom of the screen).
- In the XY cursor mode, X cursor is used to measure the waveform amplitude of CH1.

- **Y Cursor**

Y cursor is a horizontal solid/dotted line that is used to make vertical adjustments. It can be used to measure amplitude (the unit is the same as that of the source channel amplitude).

- Cursor A is a horizontal solid line ( is displayed at the right section of the screen), and Cursor B is a horizontal dotted line ( is displayed at the right section of the screen).
- In the XY cursor mode, Y cursor is used to measure the waveform amplitude of CH2.

Click or tap the function navigation icon  at the lower-left corner of the screen, then select the **Cursors** icon. The **Cursors** measurement results will be displayed in the "Result" list at the right section of the screen.



```

Cursors(C1)
AX: 200ps
AY: 300mV
BX: 5ns
BY: -300mV
ΔX: 4.8ns
ΔY: -600mV
1/ΔX: 208.3MH

```

Figure 10.9 Cursor Measurement Result

- AX: indicates the X value at Cursor A.
- AY: indicates the Y value at Cursor A.
- BX: indicates the X value at Cursor B.

- BY: indicates the Y value at Cursor B.
- ΔX : indicates the horizontal spacing between Cursor A and Cursor B.
- ΔY : indicates the vertical spacing between Cursor A and Cursor B.
- $1/\Delta X$: indicates the reciprocal of the horizontal spacing between Cursor A and Cursor B.

Click or tap the measurement result list, then select **Remove** or **Setting**.

- If you select **Remove**, the current cursor measurement results will be cleared and the instrument will make new measurements. The new measurement results will be displayed at the right side of the screen under the "Result" list.
- Click or tap **Setting**. Then the "Cursors" interface is displayed. You can select the cursor mode: Manual, Track, and XY.

10.6.1 Manual Mode

In the manual cursor mode, you can adjust the cursor manually to measure the value of the waveforms of the specified source at the current cursor. If the settings for the parameter such as the cursor type and measurement source are different, the measurement results will be different for cursor measurement.

In the **Cursors** menu, click or tap **Manual** for the **Mode** item to enable the Manual cursor measurement function. The measurement results are displayed at the right side of the screen under the "Result" list. When you change the cursor position, the measurement results will be changed accordingly.

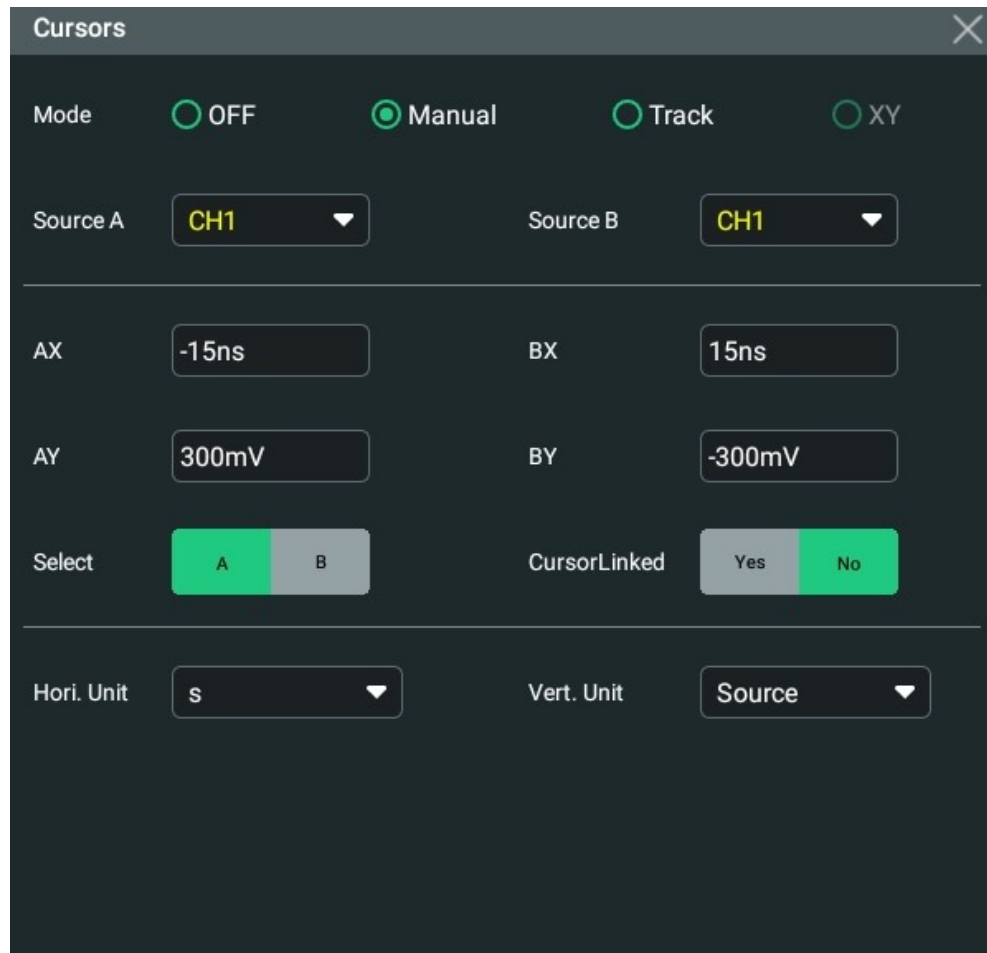

Figure 10.10 Manual Mode Setting Menu



Select the Measurement Source



- Click or tap the drop-down button of **Source A** to select the desired channel (None, CH1~CH4, or Math1-Math4).
- Click or tap the drop-down button of **Source B** to select the desired channel (None, CH1~CH4, or Math1-Math4).

If the specified channel is selected as the source, the channel will be enabled automatically.

Select the Cursor Type

Click or tap "X" or "Y" under **Select** to select the cursor type.

- **A:** When you select "A", rotate the  **Multifunction** knob at the upper-left corner of the secondary screen to make a fine adjustment of the horizontal position of Cursor A (X cursor); rotate the  **Multifunction** knob at the upper-right corner of the secondary screen to make a fine adjustment of the vertical position of Cursor A (Y cursor).

- **B:** When you select "B", rotate the  **Multifunction** knob at the upper-left corner of the secondary screen to make a fine adjustment of the horizontal position of Cursor B (X cursor); rotate the  **Multifunction** knob at the upper-right corner of the secondary screen to make a fine adjustment of the vertical position of Cursor B (Y cursor).

Adjust the Cursor Position

1. When "A" is selected under **Select**, you can adjust the position of Cursor A.
 - Click or tap the input field of **AX** and use the pop-up numeric keypad set the horizontal position of Cursor A (X cursor). The horizontal axis indicates time, and the unit of its setting value is the same as that of the horizontal unit. Its adjustable range is limited within the screen.
 - Click or tap the input field of **AY**, and then use the pop-up numeric keypad to set the vertical position of Cursor A (Y cursors). The vertical axis indicates voltage, and the unit of its setting value is the same as that of the vertical unit.
2. When "B" is selected under **Select**, you can adjust the position of Cursor B.
 - Click or tap the input field of **BX** and then use the pop-up numeric keypad to set the horizontal position of Cursor B (X cursor). The horizontal axis indicates time, and the unit of its setting value is the same as that of the horizontal unit. Its adjustable range is limited within the screen.
 - Click or tap the input field of **BY**, and then use the pop-up numeric keypad to set the vertical position of Cursor B (Y cursor). The vertical axis indicates voltage, and the unit of its setting value is the same as that of the vertical unit.

You can also use the multifunction knob  at the right side of the front panel or tap the screen to adjust the cursor.

Cursor Linked

You can click or tap **Yes** under **CursorLinked** menu to enable cursor linked to synchronize the movement of the X cursors or Y cursors. You can also press down the

 **Multifunction** knob at the upper-left corner of the secondary screen to enable the cursors to be linked.

When enabled,

- you can make adjustments of the horizontal position of Cursor A and Cursor B

by rotating the  **Multifunction** knob at the upper-left corner of the secondary screen. You can also click or tap the input field of **AX** or **BX**, then use

the pop-up numeric keypad to set the AX and BX values, and the value of ΔX remains unchanged.

- You can rotate the  **Multifunction** knob at the upper-right corner of the secondary screen to adjust the vertical position of Cursor A and Cursor B. You can also click or tap the input field of **AY** or **BY**, then use the pop-up numeric keypad to set the AY and BY values, and the value of ΔY remains unchanged.

Set the Horizontal/Vertical Measurement Unit

- Click or tap the drop-down button of **Hori. Unit** to select the desired horizontal measurement unit. The available units include "s", "Hz", "Degree($^{\circ}$)", and "Percent(%)".
 - s**: measures the time value at X Cursor (taking the trigger position as reference). The measurement results include AX, BX, ΔX , and $1/\Delta X$. Wherein, AX, BX, and ΔX all indicate time, and $1/\Delta X$ indicates frequency.
 - Hz**: measures the frequency value at X Cursor (taking the trigger position as reference). The measurement results include AX, BX, ΔX , and $1/\Delta X$. Wherein, AX, BX, and ΔX all indicate frequency, and $1/\Delta X$ indicates time.
 - Degree($^{\circ}$)**: measures the phase value at X Cursor. The measurement results include AX, BX, and ΔX , and they are all expressed in degree.

This oscilloscope allows you to set the phase reference position according to your needs. After adjusting X Cursor to a desired position, click or tap **Set Reference** to take the current cursor position as the reference. The current positions of Cursor A and Cursor B are respectively defined as "0 $^{\circ}$ " and "360 $^{\circ}$ ". Meanwhile, two vertical cursors (in blue) that cannot be moved are displayed on the screen as the phase reference position (the phase position at "0 $^{\circ}$ " and "360 $^{\circ}$ " are respectively marked by a solid line and a dotted line). Before you set manually, the oscilloscope adopts the default phase reference position.

- Percent(%)**: measures ratio at X Cursor. The measurement results include AX, BX, and ΔX , and they are all expressed in percentage.

This oscilloscope allows you to set the ratio reference position according to your needs. After adjusting X Cursor to a desired position, click or tap **Set Reference** to take the current cursor position as the reference. The current positions of Cursor A and Cursor B are respectively defined as "0%" and "100%". Meanwhile, two cursors (in blue) that cannot be moved are displayed on the screen as the ratio reference position (the ratio position at "0%" and "100%" are respectively marked by a solid line and a dotted line). Before you set manually, the oscilloscope adopts the default ratio reference position.

- You can click or tap the drop-down button of **Vert. Unit** to select the desired vertical measurement unit. The available units include "Source" and "Percent(%)".

- **Source:** measures the amplitude at Y Cursor (taking the channel ground point as the reference). The measurement results include AY, BY, and ΔY (its unit is consistent with that of the current source).
- **Percent(%):** measures ratio at Y Cursor. The measurement results include AY, BY, and ΔY , and they are all expressed in percentage.

Measurement Example

Measure the period of a sine wave by using the manual cursor measurement and auto measurement respectively. The measurement results are both 1 ms.

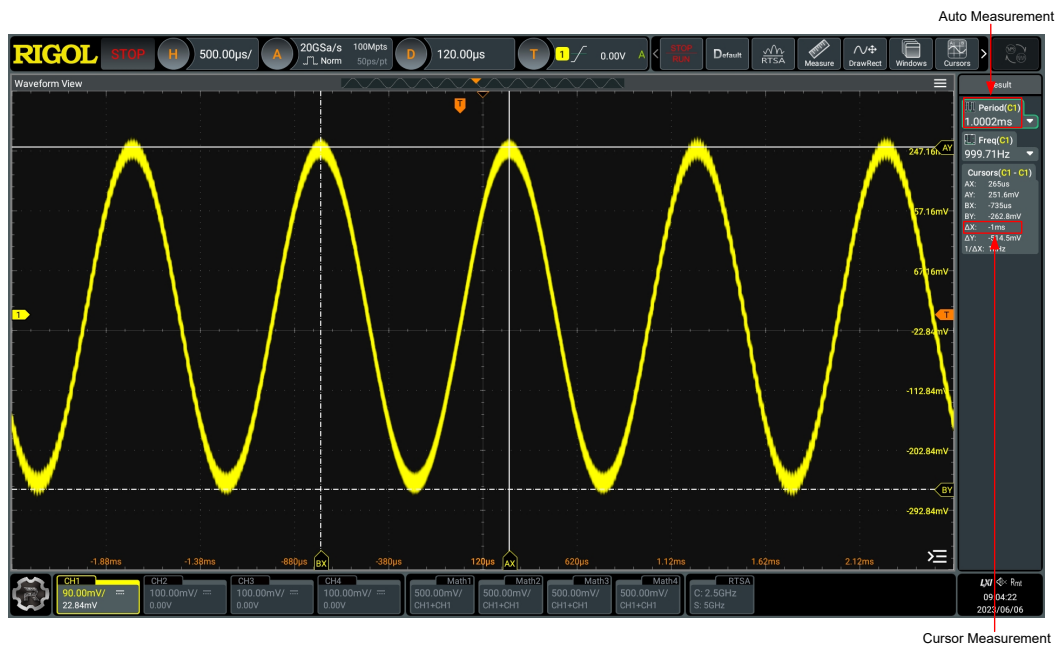

Figure 10.11 Manual Cursor Measurement Example

Close the Cursor Measurement Result Window

Click or tap **Remove** to close the cursor measurement result display window at the right side of the screen.

10.6.2 Track Mode

In the Track mode, you can adjust the two pairs of cursors (Cursor A and Cursor B) to measure the X and Y values on two different sources respectively. When the cursors are moved horizontally/vertically, the markers will position on the waveform automatically. When the waveform is expanded or compressed horizontally/vertically, the markers will track the points being marked at the last adjustment of the cursors.

In the **Cursors** menu, click or tap **Track** for the **Mode** item to enable the Track cursor measurement function. The measurement results are displayed at the right side of the screen under the "Result" list.

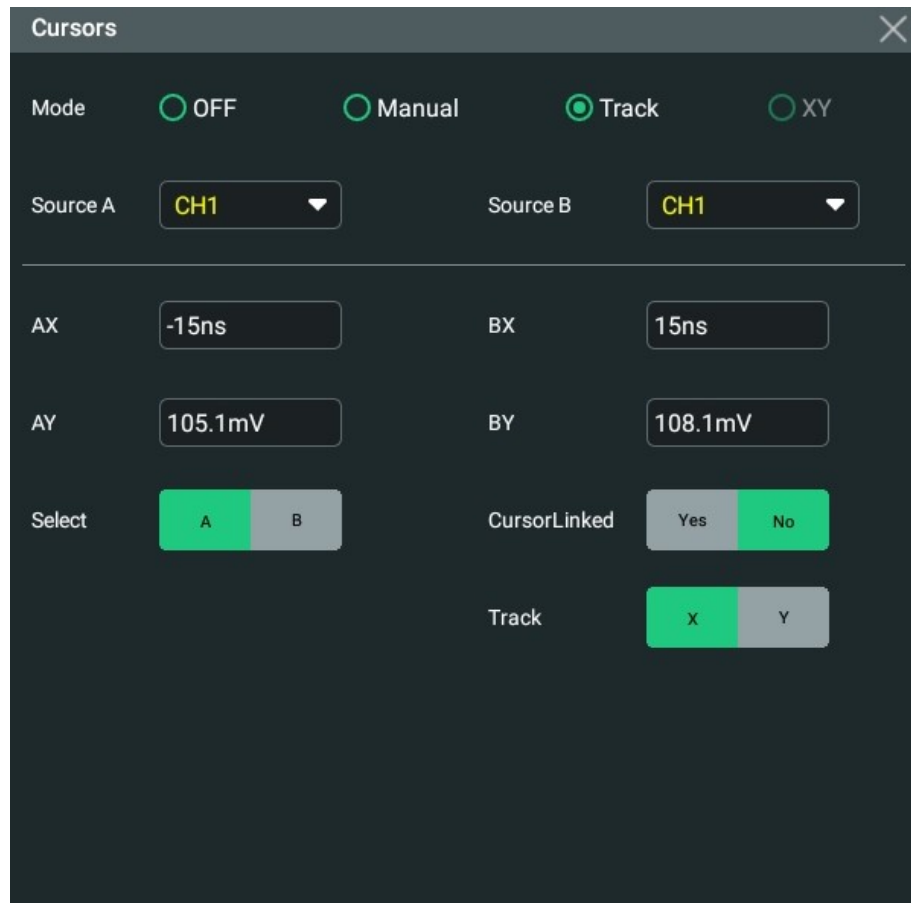

Figure 10.12 Track Mode Setting Menu

Select the Measurement Source

- Click or tap the drop-down button of **Source A** to select the desired channel (None, CH1~CH4, or Math1-Math4).
- Click or tap the drop-down button of **Source B** to select the desired channel (None, CH1~CH4, or Math1-Math4).

If the specified channel is selected as the source, the channel will be enabled automatically.





Select the Track Cursor

Click or tap "X" or "Y" under the **Track** menu item as the current track cursor. By default, it is "X".

- **X**: tracks X Cursor and measures the value at X Cursor.
- **Y**: tracks Y Cursor and measures the time of the first point at the left side of the screen.

Select Cursor Type

Click or tap "A" or "B" under **Select** to select the cursor type.

- 
A: When you select "A", rotate the **Multifunction** knob at the upper-left corner of the secondary screen to make a fine adjustment of the horizontal position of Cursor A (X cursor); rotate the  **Multifunction** knob at the upper-right corner of the secondary screen to make a fine adjustment of the vertical position of Cursor A (Y cursor).
- 
B: When you select "B", rotate the **Multifunction** knob at the upper-left corner of the secondary screen to make a fine adjustment of the horizontal position of Cursor B (X cursor); rotate the  **Multifunction** knob at the upper-right corner of the secondary screen to make a fine adjustment of the vertical position of Cursor B (Y cursor).

Adjust the Cursor Position

- When "A" is selected under **Select**, you can adjust the position of Cursor A.
 - Click or tap the input field of **AX** and use the pop-up numeric keypad to set the horizontal position of Cursor A (X cursor). The horizontal axis indicates time, and the unit of its setting value is the same as that of the horizontal unit. Its adjustable range is limited within the screen.
 - Click or tap the input field of **AY**, and then use the pop-up numeric keypad to set the vertical position of Cursor A (Y cursor). The vertical axis indicates voltage, and the unit of its setting value is the same as that of the vertical unit.
- When "B" is selected under **Select**, you can adjust the position of Cursor B.
 - Click or tap the input field of **BX** and then use the pop-up numeric keypad to set the horizontal position of Cursor B (X cursor). The horizontal axis indicates time, and the unit of its setting value is the same as that of the horizontal unit. Its adjustable range is limited within the screen.
 - Click or tap the input field of **BY**, and then use the pop-up numeric keypad to set the vertical position of Cursor B (Y cursor). The vertical axis indicates voltage, and the unit of its setting value is the same as that of the vertical unit.

You can also use the multifunction knob  at the right side of the front panel or tap the screen to adjust the cursor.

Cursor Linked

You can click or tap **Yes** under **CursorLinked** menu to enable cursor linked to synchronize the movement of the X cursors or Y cursors. You can also press down the

 **multifunction** knob at the upper-left corner of the secondary screen to enable the cursors to be linked.

When enabled,

- you can make adjustments of the horizontal position of Cursor A and Cursor B

by rotating the  **multifunction** knob at the upper-left corner of the secondary screen. You can also click or tap the input field of **AX** or **BX**, then use the pop-up numeric keypad to set the AX and BX values, and the value of ΔX remains unchanged.

- You can rotate the  **multifunction** knob at the upper-right corner of the secondary screen to adjust the vertical position of Cursor A and Cursor B. You can also click or tap the input field of **AY** or **BY**, then use the pop-up numeric keypad to set the AY and BY values, and the value of ΔY remains unchanged.

Measurement Example

Measure the waveforms of CH1 and CH2 with Cursor A and Cursor B, respectively. Then, expand the waveforms horizontally, and you will find that the cursor will track the point that has been marked, as shown in the following figure.

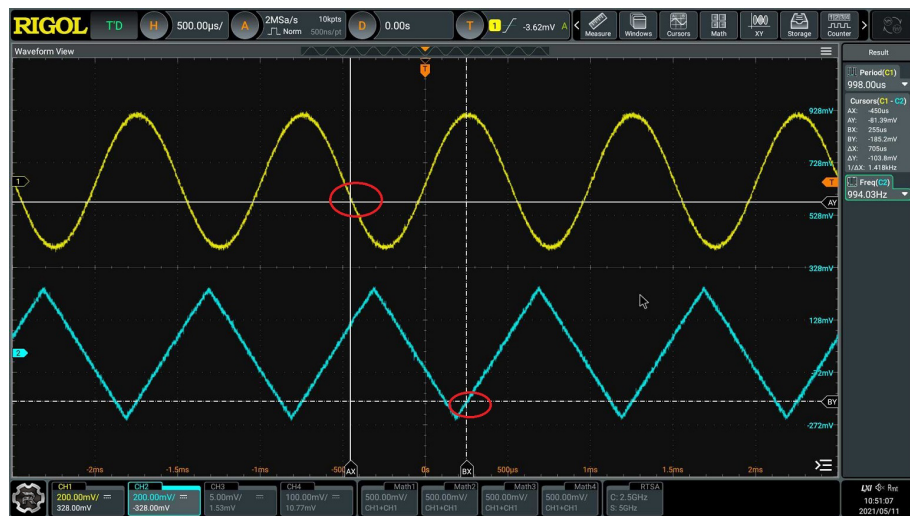

Figure 10.13 Track Measurement (before Horizontal Expansion)



Figure 10.14 Track Measurement (after Horizontal Expansion)

Close the Cursor Measurement Result Window

Click or tap **Remove** to close the cursor measurement result display window at the right side of the screen.

10.6.3 XY Mode

In the **Cursors** menu, click or tap **XY** for the **Mode** item to enable the XY cursor measurement function. The measurement results are displayed at the right side of the screen under the "Result" list.

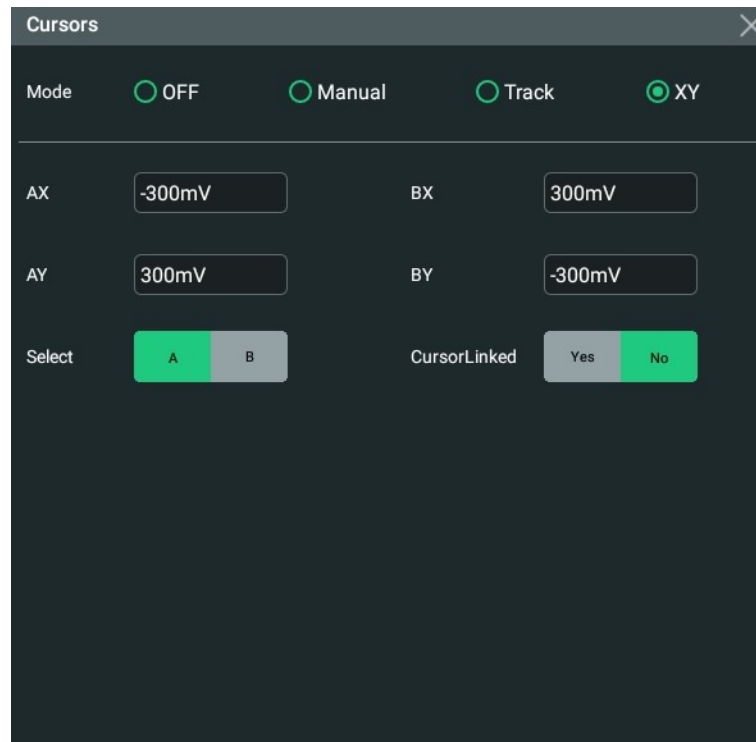

Figure 10.15 XY Mode







TIP

By default, XY mode is unavailable. It is only available when the horizontal time base mode is "XY".

To add the XY mode, click or tap the **Windows** icon at the upper-right part of the screen to enter the **Add Window** interface. In the **Diagram** menu, click or tap **XY**, and then click or tap **Add** to open the "**XY horizontal time base window**". Only when you have made such settings, can the **XY** mode be available for the cursor mode under the **Cursors** menu.

Select the Cursor Type

Click or tap "A" or "B" under **Select** to select the cursor type.

- A:** When you select "A", rotate the  **Multifunction** knob at the upper-left corner of the secondary screen to make a fine adjustment of the horizontal position of Cursor A (X cursor); rotate the  **Multifunction** knob at the upper-right corner of the secondary screen to make a fine adjustment of the vertical position of Cursor A (Y cursor).
- B:** When you select "B", rotate the  **Multifunction** knob at the upper-left corner of the secondary screen to make a fine adjustment of the horizontal position of Cursor B (X cursor); rotate the  **Multifunction** knob at the upper-

right corner of the secondary screen to make a fine adjustment of the vertical position of Cursor B (Y cursor).

Adjust the Cursor Position

1. When "A" is selected under **Select**, you can adjust the position of Cursor A.
 - Click or tap the input field of **AX** and use the pop-up numeric keypad to set the horizontal position of Cursor A (X cursor). The horizontal axis indicates time, and the unit of its setting value is the same as that of the horizontal unit. Its adjustable range is limited within the screen.
 - Click or tap the input field of **AY**, and then use the pop-up numeric keypad to set the vertical position of Cursor A (Y cursor). The vertical axis indicates voltage, and the unit of its setting value is the same as that of the vertical unit.
2. When "B" is selected under **Select**, you can adjust the position of Cursor B.
 - Click or tap the input field of **BX** and then use the pop-up numeric keypad to set the horizontal position of Cursor B (X cursor). The horizontal axis indicates time, and the unit of its setting value is the same as that of the horizontal unit. Its adjustable range is limited within the screen.
 - Click or tap the input field of **BY**, and then use the pop-up numeric keypad to set the vertical position of Cursor B (Y cursor). The vertical axis indicates voltage, and the unit of its setting value is the same as that of the vertical unit.

You can also use the multifunction knob  at the right side of the front panel or tap the screen to adjust the cursor.

Cursor Linked

You can click or tap **Yes** under **CursorLinked** menu to enable cursor linked to synchronize the movement of the X cursors or Y cursors. You can also press down the



Multifunction Knob at the upper-left corner of the secondary screen to enable the cursors to be linked.

When enabled,

- you can make adjustments of the horizontal position of Cursor A and Cursor B

by rotating the  **Multifunction** knob at the upper-left corner of the secondary screen. You can also click or tap the input field of **AX** or **BX**, then use the pop-up numeric keypad to set the AX and BX values, and the value of ΔX remains unchanged.

- You can rotate the  **Multifunction** knob at the upper-right corner of the secondary screen to adjust the vertical position of Cursor A and Cursor B. You

can also click or tap the input field of **AY** or **BY**, then use the pop-up numeric keypad to set the AY and BY values, and the value of ΔY remains unchanged.

Close the Cursor Measurement Result Window

Click or tap **Remove** to close the cursor measurement result display window at the right side of the screen.

11 Digital Voltmeter (DVM) and Frequency Counter

DS80000 series oscilloscope provides a built-in digital voltmeter (DVM) and frequency counter, which enable you to perform an accurate measurement, improving user experience in counter and frequency measurement.

11.1 Digital Voltmeter (DVM)

The built-in DVM of this oscilloscope provides 4-digit voltage measurements on any analog channel. DVM measurements are asynchronous from the oscilloscope's acquisition system and are always acquiring. You can enable the DVM measurement in the following method:

- Click or tap the function navigation icon  at the lower-left corner of the screen to open the function navigation menu. Then click or tap **DVM** to enable the DVM measurements.
- You can also click or tap the "DVM" icon on the quick operation toolbar at the top of the screen to enable the DVM measurement.

After the DVM measurement is enabled, the "DVM" label displaying the current voltage value and voltage mode appears in the "Result" list at the right section of the screen, as shown in the figure below.

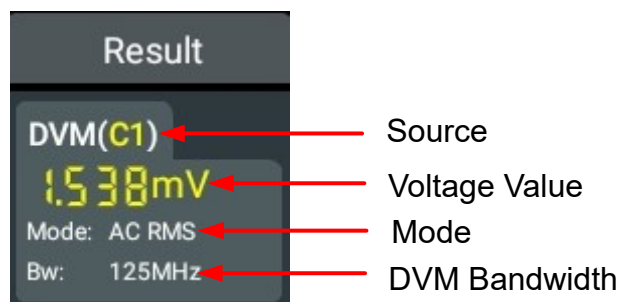

The specific value above shows the measurement extrema over the last 3 seconds.

Click or tap the DVM result list, and then two sub-menus are displayed: **Remove** and **Setting**. Click or tap **Setting** to enter the DVM setting menu.

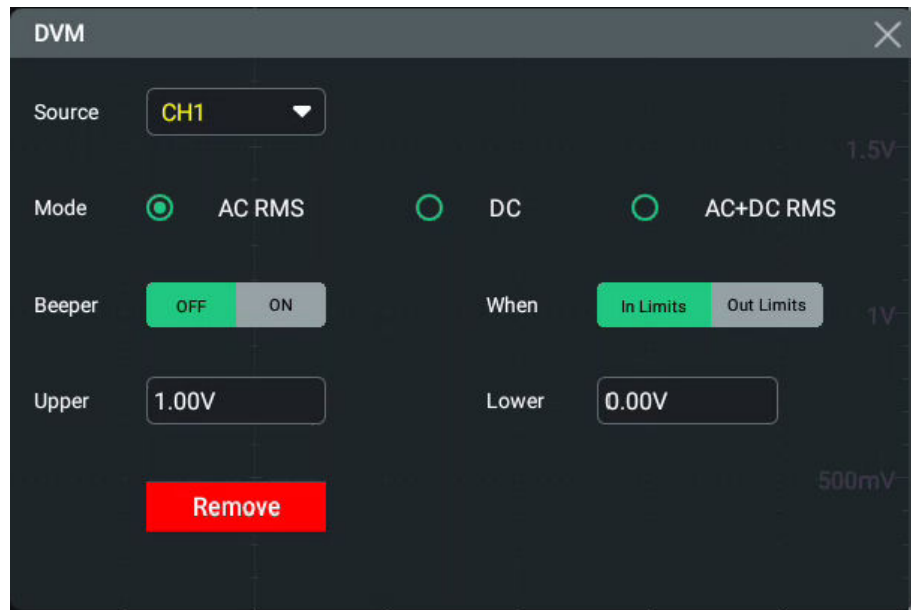

Figure 11.1 DVM Setting Menu

To exit the DVM setting menu, click or tap **Remove** shown at the left side of the DVM result list. You can also click or tap **Remove** in the DVM **Setting** menu.

11.1.1 Measurement Settings

After the DVM is enabled, the DVM result list displayed at the right section of the screen. Click or tap the result list, and then select **Setting**. Then the DVM interface is displayed. You can set the DVM parameters such as measurement source, mode, and limit value setting.

Select Measurement Mode

Click or tap to select the desired mode under the **Mode** menu. The DVM measurement modes include AC RMS, DC, and AC+DC RMS.

- **AC RMS:** displays the root-mean-square value of the acquired data, with the DC component removed.
- **DC:** displays the average value of the acquired data.
- **AC+DC RMS:** displays the root-mean-square value of the acquired data.

Select the Measurement Source

Click or tap the drop-down button of **Source** to select the desired source from the drop-down list. The analog channel (CH1~CH4) can all be selected as the source.

Even if the analog channel (CH1~CH4) is not enabled, you can still perform the DVM measurement.

Set the Limits

When setting the limits, you can select when to turn on or off the beeper once it reaches the limit line.

- Limits Condition Setting

Click or tap to select the desired condition under the **When** menu. The limits conditions include "In Limits" and "Out Limits".

- **In Limits:** when the voltage value is within the limits, you can enable or disable the beeper to sound an alarm.
- **Out Limits:** when the voltage value is outside of the limits, you can enable or disable the beeper to sound an alarm.

- Upper/Lower Limit Setting

Click or tap the input field of **Upper**, then use the pop-up numeric keypad to set the upper limit of the voltage.

Click or tap the input field of **Lower**, and then use the pop-up numeric keypad to set the lower limit of the voltage.

11.1.2 Remove the Measurement

Click or tap the DVM result list, and then two menu items are displayed at its left side. Click or tap **Remove** to clear the measurement result. Then the DVM result list is disappeared. You can also click or tap **Remove** in the DVM setting menu shown by clicking or tapping **Setting** at the left side of DVM result list.

11.2 Frequency Counter

The frequency counter analysis function provides frequency, period, or edge event counter measurements on any analog channel. You can enable the counter in the following ways:

- Click or tap the function navigation icon  at the lower-left corner of the screen to open the function navigation menu. Then click or tap **Counter** to enable the frequency counter.
- You can also click or tap the "Counter" icon on the quick operation toolbar at the top of the screen to enable the frequency counter.

When enabled, the result is displayed at the right section of the screen, showing the current measurement results of the frequency counter.

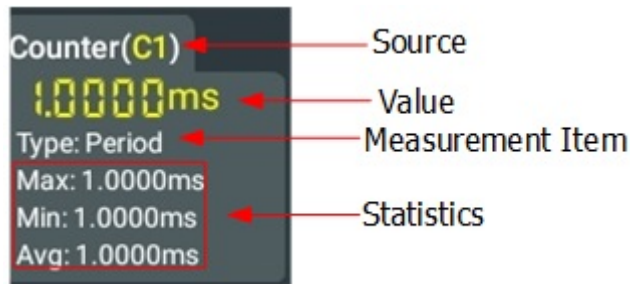

Click or tap the frequency counter result list, and then three sub-menus are displayed: **Reset Stat.**, **Remove**, and **Setting**. To exit the frequency counter setting menu, click or tap **Remove** shown at the left side of the frequency counter result list. You can also click or tap **Remove** in the **Setting** menu of the frequency counter.

11.2.1 Measurement Settings

After the frequency counter is enabled, the frequency counter result list displayed at the right section of the screen. Click or tap the result list, and then select **Setting**. Then the frequency counter interface is displayed. You can set the parameters such as measurement source, measurement item, and resolution.

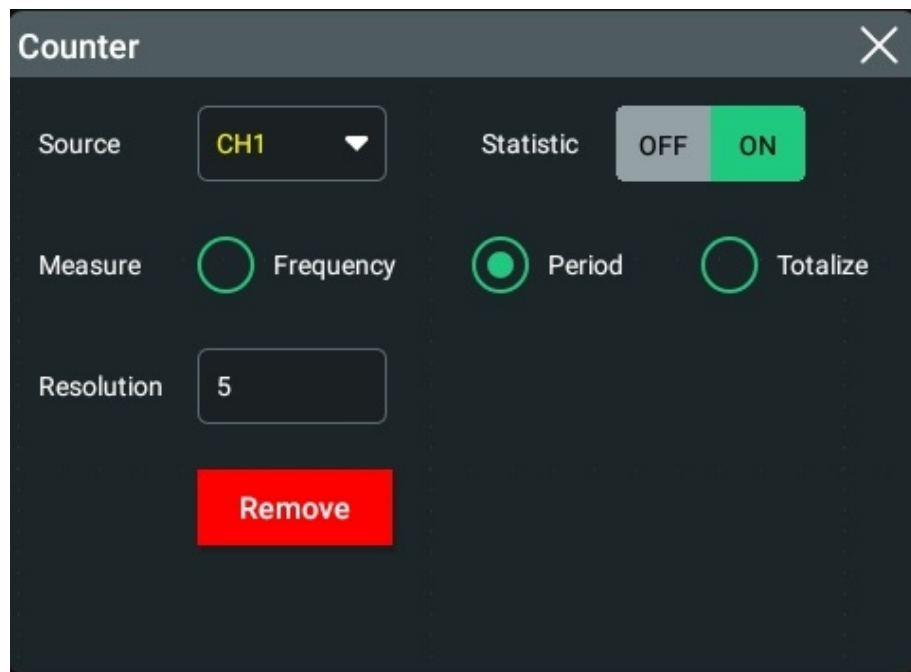

Figure 11.2 Frequency Counter Setting Menu

Select the Measurement Source

Click or tap the drop-down button of **Source** to select the desired source from the drop-down list. The analog channel (CH1~CH4) can all be selected as the source.

Set the Resolution

For Period and Frequency measurements, you need to set the readout resolution. Click or tap the input field of **Resolution** to set the resolution by using the pop-up numeric keypad. The range of resolution is from 3 bits to 8 bits. By default, it is 5 bits.

The greater the resolution, the longer the gate time. In this way, the measurement time will be longer.

Select the Measurement Item

The measurement items supported by the frequency counter of this oscilloscope include Frequency, Period, and Totalize measurements. Wherein, Totalize indicates the count of edge events on the signal.

Select the desired measurement item from the **Measure** menu: Frequency, Period, and Totalize.

Clear Count

When "Totalize" is selected as the measurement item, the oscilloscope measures the count of edge events on the signal. At this time, click or tap **Clear Count** to clear the measurement results.

Statistics Results

Click or tap the ON/OFF button for the **Statistic** item to enable/disable the statistical function. When enabled, all the statistical results will be displayed in the "**Counter**" result list.

11.2.2 Reset Statistics

Click or tap **Reset Stat.** to reset the statistics.



11.2.3 Remove the Measurement

Click or tap the frequency counter result list, and then three menu items are displayed at its left side. Click or tap **Remove** to clear the measurement result. The frequency counter result list is disappeared. You can also click or tap **Remove** in the counter setting menu shown by clicking or tapping **Setting** at the left side of the frequency counter result list.

12 Histogram Analysis

DS80000 series oscilloscope supports the histogram analysis function, enabling you to judge the trend of waveforms, and quickly locate the potential problems of the signal.

To enter the histogram analysis function, perform any of the following operations:

- Click or tap the function navigation icon  at the lower-left corner of the screen, and then select **Histogram** to enter the histogram setting menu.
- Tap the **Histogram** icon on the secondary screen to enter the histogram setting menu.
- Click or tap  > **DrawRect** to switch to the rectangle drawing mode. Move your finger to draw a rectangular on the screen, and then the menu is displayed. Tap to select "Histogram", then the histogram results analysis is displayed in the **Result** window at the right section of the screen. Tap the rectangular area to enter the histogram setting interface. You can also tap the "Rectangular" analysis results label to select **Setting** to enter the histogram setting menu.

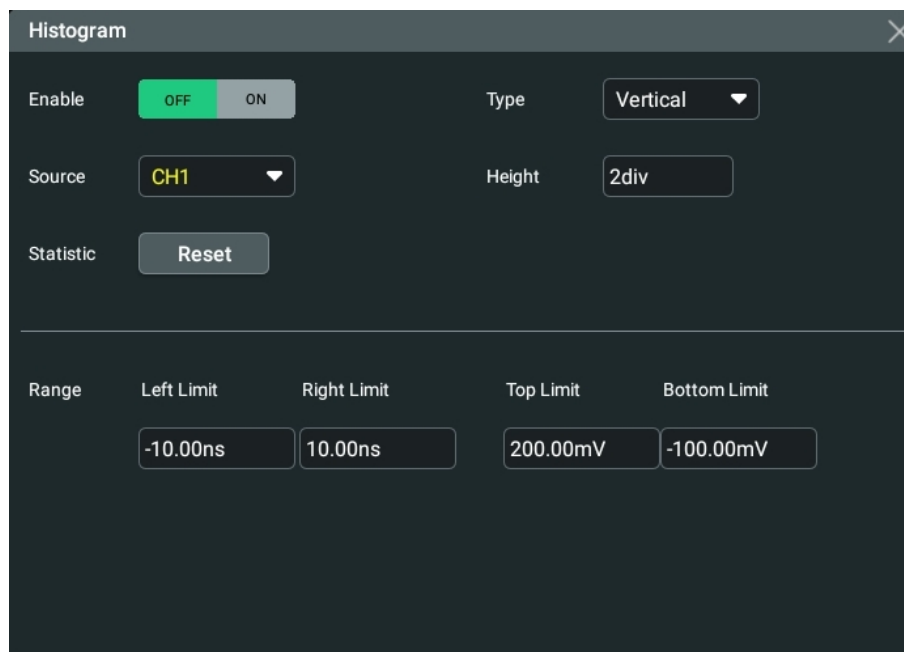

Figure 12.1 Histogram Setting Menu

12.1 To Enable or Disable the Histogram Function

In the "histogram" setting menu, click or tap the ON/OFF tab for the **Enable** menu to enable or disable the histogram analysis function. When enabled, the histogram is

displayed on the screen, and the histogram analysis results are displayed in the "Result" list at the right section of the screen.

12.2 To Select the Histogram Type

In the "Histogram" setting menu, click or tap the drop-down button of **Type** to select the histogram type from the drop-down list.

- Horizontal: displays the number of times for statistics making in the forms of columns in the histogram bar graph at the bottom of the graticule.

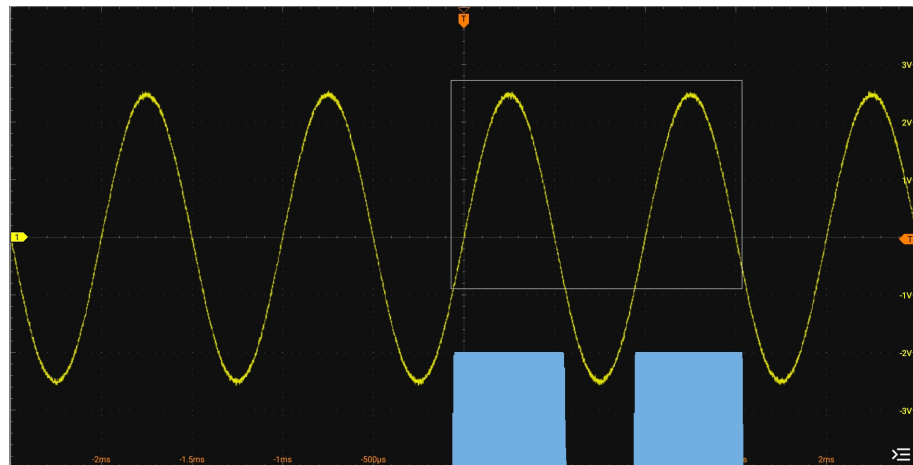

- Vertical: displays the number of times for statistics making in the forms of rows in the histogram bar graph at the left of the graticule.

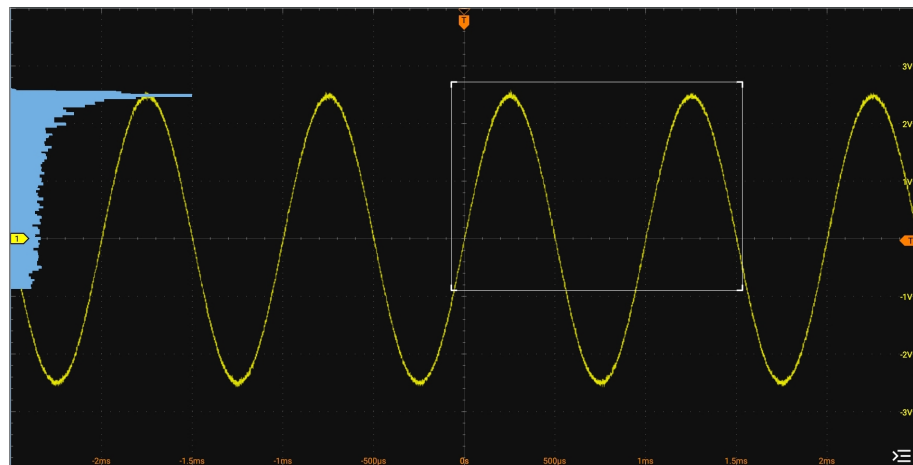

12.3 To Select the Histogram Source

In the "Histogram" setting menu, click or tap the drop-down button of **Source** to select the desired source from the drop-down list. The analog channel (CH1~CH4) can be selected as the source of the histogram.

12.4 To Set the Histogram Height

Click or tap the input field of **Height** and use the pop-up numeric keypad to set the height of the histogram.

The range of the histogram height is from 1 div to 4 div. By default, it is 2 div.

12.5 Statistics

Press **Reset** to reset the statistical data and restart to make statistics.

12.6 To Set the Histogram Range

When "Horizontal" or "Vertical" is selected under Type, you need to set the window range. Set "Left Limit", "Right Limit", "Top Limit", and "Bottom Limit" respectively to adjust the size and position of the histogram window.

- Click or tap the input field of **Left Limit** and use the pop-up numeric keypad to set the left limit of the histogram.
- Click or tap the input field of **Right Limit** and use the pop-up numeric keypad to set the right limit of the histogram.
- Click or tap the input field of **Top Limit** and use the pop-up numeric keypad to set the top limit of the histogram.
- Click or tap the input field of **Bottom Limit** and use the pop-up numeric keypad to set the bottom limit of the histogram.

NOTE

The adjustment for the horizontal time base and vertical scale will not affect the time base of the histogram range, but only shows variation with the scale.

TIP

You can also directly drag the left, right, top, or bottom edge of the white histogram diagram window to adjust the position and size the histogram.

12.7 Histogram Analysis Results

In the "histogram" setting menu, click or tap the ON/OFF tab for the **Enable** menu to enable or disable the histogram analysis function. When enabled, the histogram analysis results are displayed in the **Results** list at the right section of the screen.



Figure 12.2 Histogram Analysis Results

- Sum: indicates the sum of all bins (buckets) in the histogram.
- Peaks: indicates the maximum number of hits in any single bin.
- Max: indicates the value that corresponds to the maximum bin that has any hits.
- Min: indicates the value that corresponds to the minimum bin that has any hits.
- Pk_Pk: indicates the Delta between the max. value and the min. value.
- Mean: indicates the average value of the histogram.
- Median: indicates the median value of the histogram.
- Mode: indicates the mode value of the histogram.
- Bin width: indicates the width of each bin (bucket) in the histogram.
- Sigma: indicates the standard deviation of the histogram.
- XScale: indicates the horizontal scale of the histogram. It is 100 times the value of Bin width.
- $\mu\pm\sigma$: indicates the proportion of the number of frequencies or counts of the histogram hits that lie within one standard deviation of the mean to the total number of histogram hits. μ indicates the mean value in normal distribution. It is

the average of the numbers. σ indicates the standard deviation in the normal distribution.

- $\mu \pm 2\sigma$: indicates the proportion of the number of frequencies or counts of the histogram hits that lie within two standard deviations of the mean to the total number of histogram hits. μ indicates the mean value in normal distribution. It is the average of the numbers. σ indicates the standard deviation in the normal distribution.
- $\mu \pm 3\sigma$: indicates the proportion of the number of frequencies or counts of the histogram hits that lie within three standard deviations of the mean to the total number of histogram hits. μ indicates the mean value in normal distribution. It is the average of the numbers. σ indicates the standard deviation in the normal distribution.

Click or tap the Histogram analysis result list, then **Setting** and **Remove** menus are displayed. You can set the parameters for the histogram. Click or tap **Setting**, the histogram setting interface is displayed. Click or tap **Remove**, the histogram analysis results are cleared.

13 Real-time Eye Analysis (Option)

The DS80000 series oscilloscope provides the real-time eye plot and measurement with the clock recovery function. If you have purchased and activated the DS80000-JITTA option, the real-time eye diagram is supported by the oscilloscope.

An eye diagram is a view of a signal. A real-time eye accomplishes this by acquiring data, performing clock recovery, then superimposing (folding) successive unit intervals within a single plot. This is a statistical view in the form of a color grade. The eye analysis function is usually used to observe the waveforms of the Receive signal to analyze the impact of inter-symbol interference (ISI) and noise on the system performance.

Click or tap the function navigation icon  at the lower-left corner of the screen to open the function navigation. Then, click or tap the **Eye** icon to enter the "Eye" setting menu. You can also tap the **Eye** menu on the secondary screen to enter the "Eye" setting menu.

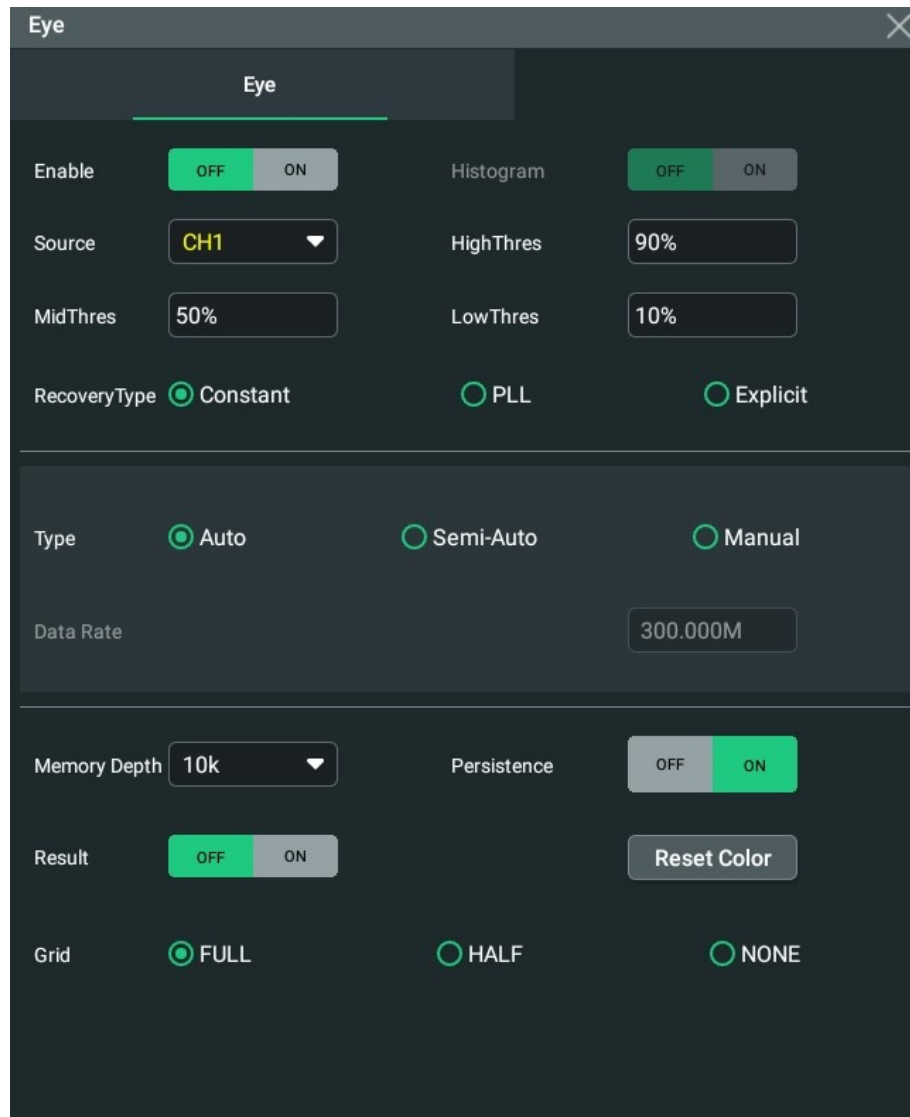

Figure 13.1 Eye Diagram Setting Menu

If you have purchased the option, activate it according to the descriptions in [To View the Option Information and the Option Installation](#).

13.1 To Enable or Disable the Eye Analysis Function

In the "eye" setting menu, click or tap the ON/OFF tab for the **Enable** menu to enable or disable the eye analysis function. When enabled, the eye diagram window is displayed on the screen.

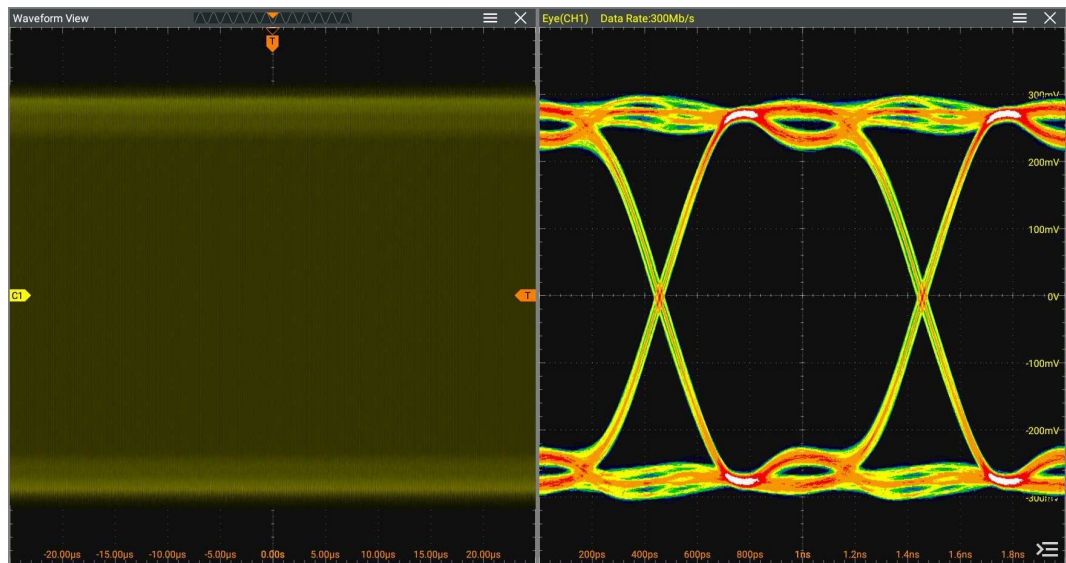

Figure 13.2 Eye Measurement Result



TIP

The eye diagram can only be obtained when the horizontal time base is less than or equal to 1 ms/div.



NOTE

In the "Eye" setting menu, you can also click or tap the ON/OFF tab for **Enable** under the **Histogram** menu to enable or disable the histogram analysis function at the same time. Once enabled the histogram, the histogram measurement can be performed. The histogram measurement results are the same as those in the Histogram module.

13.2 To Select the Source of the Eye Diagram

In the "Eye" setting menu, click or tap the drop-down button of **Source** to select the desired source from the drop-down list. The analog channel (CH1~CH4) can be selected to be the eye source.

13.3 Threshold Settings

In the eye setting menu, you can set the high, middle, and low threshold values.

- **Set the high threshold**

Click or tap **HighThres**, then use the pop-up numeric keypad to set the high threshold.

If you reduce the high threshold to a value below the set middle threshold, the oscilloscope will adjust the high threshold automatically to make it greater than the middle threshold.

- **Set the middle threshold**

Click or tap the input field of **MidThres**, then use the pop-up numeric keypad to set the middle threshold.

The middle threshold is limited by the set low threshold and high threshold.

- **Set the low threshold**

Click or tap **LowThres**, then use the pop-up numeric keypad to set the low threshold.

If you increase the low threshold to a value above the set middle threshold, the oscilloscope will decrease the low threshold automatically to make it smaller than the middle threshold.

13.4 To Set Clock Recovery

The clock recovery provides an ideal clock for comparison to actual signal edges.

In the "Eye" setting menu, click or tap Constant, PLL, or Explicit under the **RecoveryType** menu.

1. Setting method for constant clock recovery

Click or tap to select "Constant" in the **RecoveryType** menu.

- Set the data rate type.

Click or tap to select the desired data rate type under the **Type** menu. The data rate type for Constant includes Auto, Semi-Auto, and Manual.

- Auto: recovers the clock based on the narrowest pulse of the signal.
- Semi-Auto: recovers the clock by the manually preset data rate and the signal edge.
- Manual: recovers the clock by the data rate input manually.
- Set the data rate

Click or tap the input field of **Data Rate**, then use the pop-up numeric keypad to set the data rate.

2. Setting method for phase-locked loop (PLL)

Click or tap to select "PLL" in the **RecoveryType** menu.

- Set the data rate

Click or tap the input field of **Data Rate**, then use the pop-up numeric keypad to set the data rate.

- Set the PLL order

This oscilloscope supports first-order PLL and second-order PLL. Select "1st Order" or "2nd Order" from the **PLL Order** menu.

- Set the loop BW

Click or tap the input field of **Loop BW** to set the loop bandwidth by using the pop-up numeric keypad.

- Set the damping factor

When PLL order is set to "2nd Order", you need to set the damping factor. It is the damping factor of the transfer function. Click or tap the input field of **DampFactor** to set the damping factor by using the pop-up numeric keypad.

The typical damping factor is 1.0 and 0.707. The former is critically damped, and the latter is the ideal or optimal value.

3. Set the clock recovery type

Click or tap to select "Explicit" in the **RecoveryType** menu.

Click or tap the drop-down button of **Source** to select the desired source from the drop-down list. The analog channel (CH1~CH4) can all be selected as the source for external clock.

13.5 To Set the Data Rate

In the eye setting menu, you can set the data rate type and data rate.

Type

Click or tap the data rate type: Auto, Semi-Auto, and Manual.

Data Rate

When the data rate type is set to "Semi-Auto" or "Manual", you can set the data rate.

Click or tap the input field of **Data Rate** and use the pop-up numeric keypad to set the data rate. Its range is from 100 k to 26 G. Its default value is 10 M.

13.6 Eye Measurement Result

In the "eye" setting menu, click or tap the ON/OFF tab for the **Result** menu to enable or disable the display of the measurement results. When enabled, the "**Result**" list at the right side of the screen shows the eye measurement result.

```

EyeResult(C1)
One: 3.263V
Zero: 157.4mV
Width: 618.8ns
Height: 2.873V
Amp: 3.106V
Cross: 48%
Q Factor: 40.1
BR: 1.501Mb/s
riseTime: 156.8ns
fallTime: 142.1ns
crossTime1:340.2ns
crossTime2:1.003us
DCDTime: 84.7ns
DCDPercent:12.7%

```

- One: indicates "1" level.
- Zero: indicates "0" level.
- Width: indicates the width of an eye diagram.
- Height: indicates the height of an eye diagram.
- Amp: indicates the amplitude of an eye diagram.
- Cross: indicates the crossing percentage of an eye diagram.
- Q Factor: indicates the Q factor.
- BR: indicates bit rate.
- riseTime: indicates the rising time.
- fallTime: indicates the falling time.
- crossTime1: indicates the level position 1 of the middle value.
- crossTime2: indicates the level position 2 of the middle value.
- DCDTime: indicates the duty cycle time.
- DCDPercent: indicates the duty cycle percentage.

The diagram of the eye measurement parameters are as shown in the figure below:

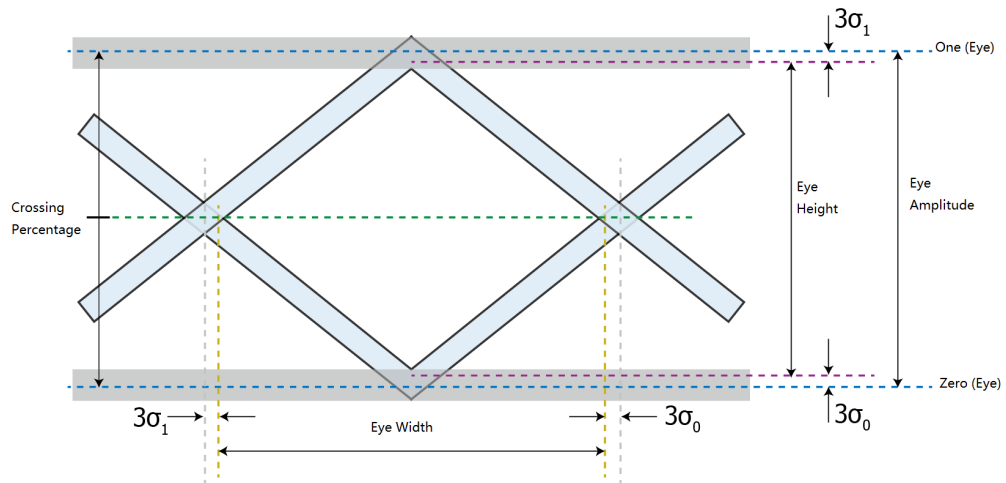

Figure 13.3 Diagram of Eye Measurement Parameters

Click or tap the eye measurement result list, and then two sub-menus are displayed:

Remove and **Setting**.

- Click or tap **Setting**, then the eye diagram menu is displayed, as shown in *Real-time Eye Analysis (Option)*.
- To close the measurement result list, click or tap **Remove**.

13.7 To Set the Display-related Parameters

Memory Depth

Click or tap the drop-down button of **Memory Depth** to select the memory depth of the eye diagram. The available choices are 10k, 100k, and 1M.

Persistence

Click or tap the ON/OFF tab for the **Persistence** menu to enable or disable the persistence function.

Reset Color

Click or tap **Reset Color** to clear the color level counter.

Grid

Click or tap "FULL", "HALF", or "NONE" for the **Grid** menu item to select the grid type displayed on the screen. For details, refer to *To Set the Screen Grid*.

14 Jitter Analysis (Option)

The jitter analysis function is mainly used to analyze the integrity of the high-speed serial signal and measure the variance of a measurement over time. The measurement items include total jitter (TJ), random jitter (RJ), deterministic jitter (DJ), period jitter (PJ), data-dependent jitter (DDJ), duty cycle distortion (DCD), inter-symbol interference (ISI), and bit ratio (BR).

Click or tap the function navigation icon  at the lower-left corner of the screen to open the function navigation. Then, click or tap the **Jitter** icon to enter the "Jitter" setting menu.

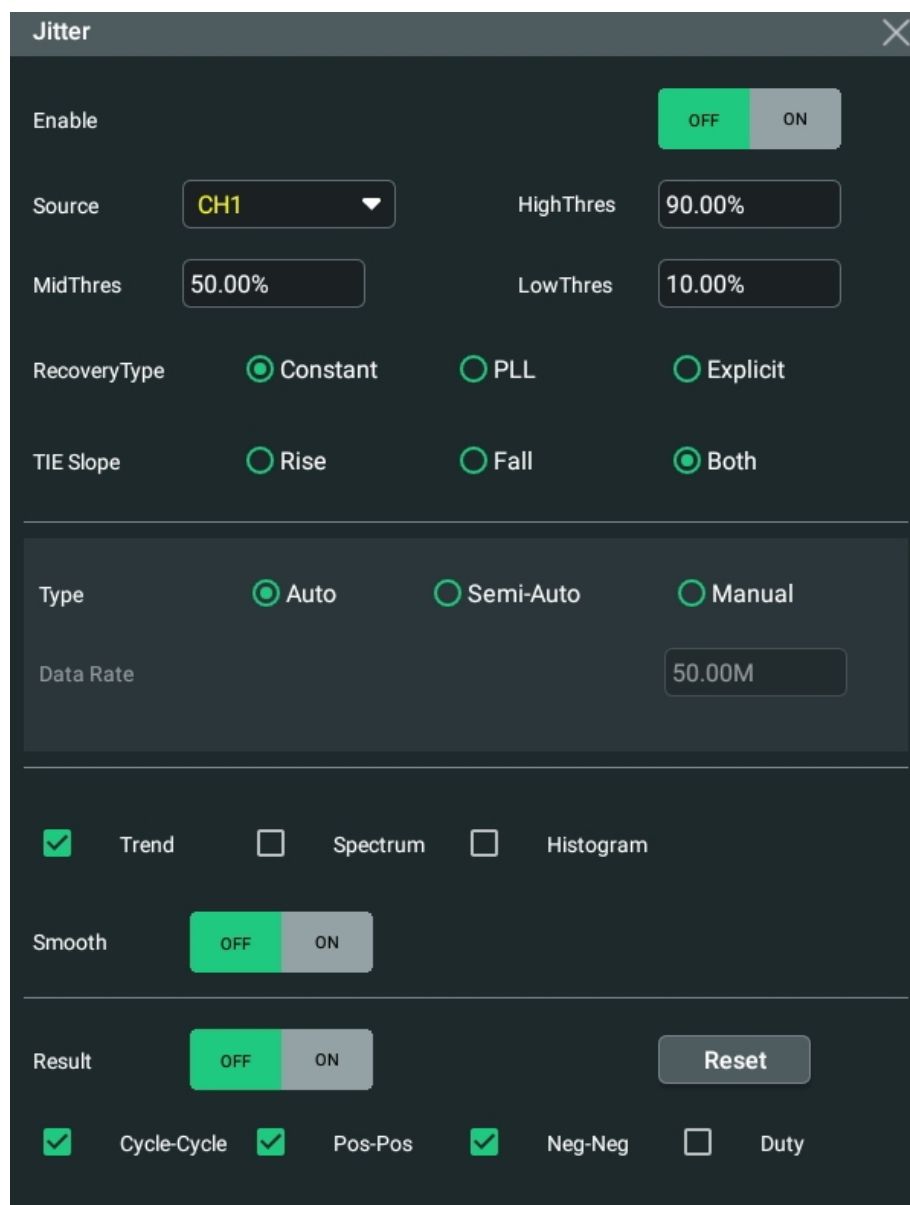

Figure 14.1 Jitter Setting Menu

If you have purchased the option, activate it according the descriptions in [To View the Option Information and the Option Installation](#).

14.1 To Enable or Disable the Jitter Function

In the "jitter" setting menu, click or tap the ON/OFF tab for the **Enable** menu to enable or disable the jitter analysis function. When enabled, the jitter diagram window is displayed on the screen.

14.2 To Set Jitter Parameters

In the "Jitter" setting menu, set the following parameters.

Select the Source

Click or tap the drop-down button of **Source** to select the desired source from the drop-down list. The analog channel (CH1~CH4) can all be selected as the source.

Threshold Settings

For details about setting the jitter measurement threshold, refer to [Threshold Settings](#).

Set the Clock Recovery

For setting methods of the clock recovery in the jitter, refer to descriptions in [To Set Clock Recovery](#).

TIE Slope

TIE indicates the time interval error. The TIE measurement compares the edges in a data signal with the edges in an ideal data signal determined by the clock recovery feature to generate error statistics. TIE slope is used to set the edge type.

Jitter Measurement Item

- **Cycle-Cycle:** measures the first cycle and then subtracts the first cycle from the second cycle. The measurement is made according to this rule.
- **Pos-Pos:** subtracts the first cycle's positive pulse width from the second cycle's positive pulse width for the first measurement result. The Pos-Pos jitter measurement subtracts the second cycle's positive pulse width from the third cycle's positive pulse width for the second measurement result, and so on, until all of the cycles of the waveform have been measured.
- **Neg-Neg:** subtracts the first cycle's negative pulse width from the second cycle's negative pulse width for the first measurement result. Then subtract the second cycle's negative pulse width from the third cycle's negative pulse width for the second measurement result, and so on, until all of the cycles of the waveform have been measured.

- **Duty:** measures the positive pulse width and the period for one period. It is the ratio of the positive pulse width to the period. The formula is as follows:

$$\text{Duty Cycle} = \text{Positive Pulse width} / \text{Period} \times 100$$



NOTE

When one or multiple jitter measurement items are selected, the measurement results of the selected items will be all displayed in the jitter result list window.

Set the Data Rate

For the jitter data rate type and data rate, refer to descriptions in [To Set the Data Rate](#).

Set the Display Format of the Jitter Measurement Result

The jitter measurement results will be displayed in the jitter window. You can click or tap to select "**Trend**", "**Spectrum**", or "**Histogram**" as the display format.

- **Trend:** The trend graph can display the trend of the jitter measurement results. The data obtained from the waveforms of the same frame are generated to form a curve, which enables users to find out the cause for jitter.

When the clock recovery method is set to "PLL", the PLL system cannot reach the expected ideal clock frequency until it reaches the specified lock time. During the lock time, the TIE jitter measurement results based on the ideal recovery clock are incorrect. The data produced during this time will be discarded in data processing. Therefore, in the TIE jitter trend graph based on the PLL recovery, part of trend graph at the left section of the screen will be lost.

- **Spectrum:** The spectrum graph shows the waveforms of the trend diagram through the FFT (Fast Fourier Transform).
- **Histogram:** The histogram shows the distribution of the jitter measurement results. Wherein, Gaussian distributions indicates random jitter, and non-Gaussian jitter has deterministic components.

Smooth

Click or tap the ON/OFF tab for the **Smooth** menu item to enable/disable the the smooth operation for the jitter.

Reset

Click or tap **Reset**, and then the instrument will restart the jitter measurement.

14.3 To View the Jitter Measurement

In the jitter setting menu, click or tap the ON/OFF tab for the **Result** menu to enable or disable the display of the jitter measurement results. By default, it is OFF. When enabled, the jitter measurement results are displayed at the right side of the screen under the "Result" list.



Jitter(1e-12)(C1)	
Tj:	*****
Rj:	*****
Dj:	*****
Pj:	*****
DDj:	*****
DCD:	*****
ISI:	*****
BR:	*****

The measurement results includes the following measurement items:

- **Tj:** indicates the total jitter.
- **Rj:** indicates the random jitter. It is compliant with the Gaussian distribution, and its source can be thermal noise, shot noise, and random noise, with non-stationary interference.
- **Dj:** indicates the deterministic jitter. It has non-Gaussian distribution and is bounded. It is characterized by Gaussian Probability Density Function (PDF) and in scattered distribution. It may be generated due to the bandwidth, reflection, crosstalk, EMI, ground bounce, and period modulation.
- **Pj:** indicates the periodic jitter. The TIE time trend of the periodic jitter is repeated and periodic. It is caused by external deterministic noise sources coupling into a system, such as measuring the periodic waveforms, system clock (with the jitter frequency above MHz level), or switching power supply (with the jitter frequency above KHz level).
- **DDJ:** indicates data-dependent jitter. It refers to any jitter that is correlated with the bit sequence in a data stream. DDJ is often caused by the frequency response of a cable or device.
- **DCD:** indicates duty cycle distortion. It is caused by the asymmetrical rise time and fall time; or the non-optimal choice of reference level. The crossing percentage in the eye diagram is similar to DCD.
- **ISI:** indicates the inter-symbol interference. It is also called data-dependent jitter (DDJ) or pattern-dependent jitter. It is caused by the effects of the transmission link, reflection, etc.

The impedance mismatch may cause signal reflection, and the reflected signal is superimposed on the original signal, increasing the signal amplitude, making level conversion time-consuming. Therefore, the constant unchanged symbol pattern will reach a higher level, and more time is required for it to reach the threshold level during hopping, thus causing signal jitter. As the amplitude of the jitter is related to the pattern, it is also called pattern-dependent jitter (PDJ).

- **BR:** indicates bit ratio.

Click or tap the jitter measurement result list, and then two sub-menus are displayed: **Remove** and **Setting**.

- Click or tap **Setting**, then the jitter menu is displayed, as shown in *Figure 14.1*.
- To close the measurement result list, click or tap **Remove**.

15 Reference Waveform

DS80000 series oscilloscope provides 10 reference waveform positions (Ref1~Ref10). In the actual test process, you can compare the signal waveform with the reference waveform to locate the failure.

15.1 To Enable the Reference Waveform

To enter the **Ref** menu, perform any of the following operations:

- Click or tap the function navigation icon  at the lower-left corner of the screen, and then select **Ref** to enter the reference waveform menu.
- Tap the **Ref** icon on the secondary screen at the right side of the screen to enter the reference waveform menu.

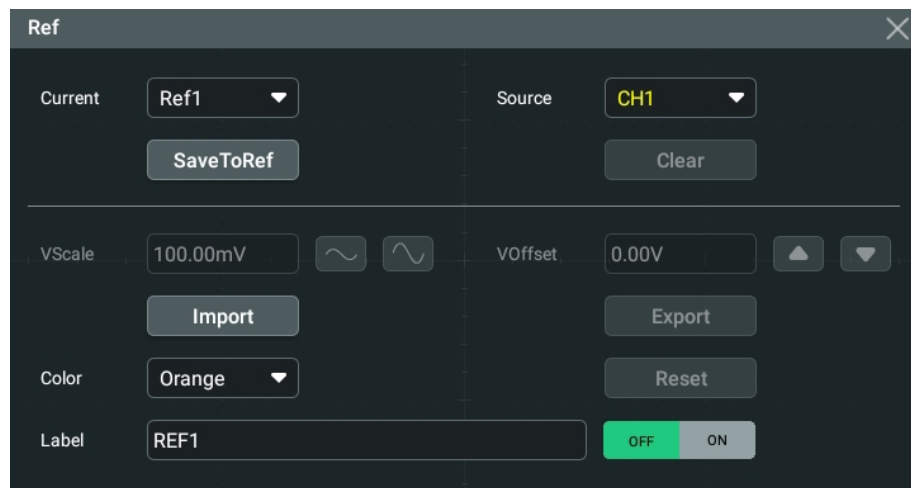

Figure 15.1 Reference Waveform Menu

When the Ref function is enabled, you can select different color for each reference waveform, set the source of each reference channel, adjust the vertical scale and offset of the reference waveform, save the reference waveform to the internal or external memory, and recall it when needed.

15.2 To Set the Reference Waveform

In the **Reference Waveform** menu, you can specify a channel to serve as the reference channel. You can save or clear the reference channel.

Select the Reference Channel

Click or tap the drop-down button of **Current** to select the reference waveform channel (Ref1-Ref10) from the drop-down list. By default, Ref1 is enabled.

To Select the Ref Source

Click or tap the drop-down button of **Source** to select the desired reference waveform source (CH1~CH4 or Math1~Math4).

Save the Reference Waveform to Internal Memory

Click or tap **SaveToRef** to save the displayed waveform for the specified source to the internal memory as the reference waveform.



CAUTION

This operation only saves the reference waveform to the volatile memory, and the waveform will be cleared at power-off or restoring to the default settings.

Clear the Specified Reference Waveform

Click or tap **Clear** to clear the specified reference waveform for the "current channel".

You can also click or tap the "Clear" icon in the function navigation menu or the **Clear** icon on the small screen to clear the reference waveforms of all the reference channels.

15.3 To Set the Reference Waveform Display

After clicking or tapping **SaveToRef** to save the reference waveform to the internal memory, you can adjust the vertical scale and offset of the reference waveform specified under **Current**.

Modify the Vertical Scale

Click or tap the input field of **VScale**, and then use the pop-up numeric keypad to set the vertical scale of the reference waveform. You can also directly click or tap the icon  at the right side of the input field of **VScale** to increase or decrease the vertical scale value. As shown in the figure below:

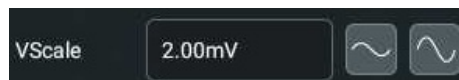

Modify the Vertical Offset

Click or tap the input field of **VOffset**, and then use the pop-up numeric keypad to set the vertical offset of the reference waveform. You can also directly click or tap the

Up and Down arrow icon  at the right side of the input field of **VOffset** to increase or decrease the vertical offset value. As shown in the figure below:



Restore the Reference Waveform

If you have adjusted the vertical scale and offset for the specified reference waveform of the current channel, to reset the reference waveform to the position where the source channel stays prior to the **Save** operation, click or tap **Reset**.

Set the Reference Waveform Color

DS80000 series oscilloscope provides five colors (gray, green, light blue, red, and orange) to mark the reference waveforms of different channels in order to distinguish them.

Click or tap the drop-down button of **Color** to select the color of the reference waveform of the channel.

Set the Reference Waveform Label

Click or tap the ON/OFF tab for the **Label** menu to enable or disable the label display of the specified reference waveform.

Click or tap the input field of "Label" to set the label of the specified reference channel with the pop-up numeric keypad.

15.4 Export and Import Operation

Export to Internal or External Memory

You can save the current reference waveform to the internal memory or external USB storage device. The file format of the reference waveform is "*.ref", "*.bin", or "*.csv".

Click or tap **Export** to enter the reference waveform file saving interface.

- **Set the Format**

In the file saving interface, click or tap the drop-down button of **Format** to select "*.ref", "*.bin", or "*.csv" as the saving format.

- **Set the Filename**

Click or tap the input field of **File Name**, then the filename editing interface is displayed. Input the filename with the pop-up numeric keypad.

For the methods of using the numeric keypad, refer to descriptions in *Parameter Setting Method*.

- **Set the Save Path**

Click or tap the input field of **File Path**, then the disk management interface is displayed. Through the disk management menu, you can save the current reference waveform to the internal memory or external USB storage device. Only when the reference waveform is saved, can this export function be valid. For detailed operations, refer to descriptions in *Disk Management*. Then, click or tap **Save** to complete the save operation.

**TIP**

DS80000 series oscilloscope only supports the flash memory USB storage device of FAT32 format.

For the "*.bin" format file, refer to *Binary Data Format (.bin)*.

Import from Internal or External Memory

You can import the stored reference waveform file from the internal memory or external USB storage device to the internal instrument and display the file on the screen.

Click or tap **Import** to enter the reference waveform file loading interface.

- **Set the Format**

In the file loading interface, click or tap the drop-down button of **Format** to select "*.ref" as the loading format.

- **Set the Load Path**

Click or tap the input field of **File Path**, then the disk management interface is displayed. Through the disk management menu, you can load the current reference waveform to the waveform view of the oscilloscope. For details about the disk management operation, refer to the *Disk Management*. Then, click or tap **Load** to complete the load operation.

16 Pass/Fail Test

During the product design and manufacturing process, you usually need to monitor the variations of the signal or judge whether the product is up to standard. The pass/fail test function of DS80000 series oscilloscope can accomplish this task perfectly.

To enter the Pass/Fail menu, perform any of the following operations:

- Click or tap the function navigation icon  at the lower-left corner of the screen to open the function navigation. Then, click or tap the **Pass/Fail** icon to enter the "Pass/Fail" setting menu.
- You can also tap the **Pass/Fail** icon on the small screen to enter the "Pass/Fail" setting menu.

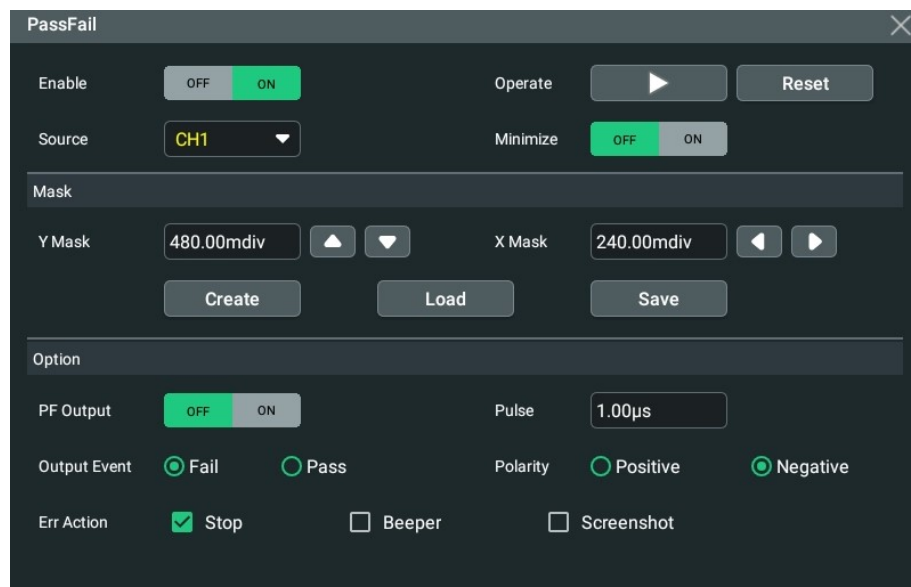

Figure 16.1 Pass/Fail Test Menu

Click or tap the ON/OFF tab for the **Minimize** menu to enable or disable minimizing the PassFail test window, as shown in the figure below.



Figure 16.2 Minimized Pass/Fail Test Window

16.1 To Enable or Disable the Pass/Fail Test Function

In the "Pass/Fail" setting menu, click or tap the ON/OFF tab for the **Enable** menu to enable or disable the pass/fail test function.

16.2 To Start or Stop the Pass/Fail Test Operation

After the Pass/Fail test function is enabled, click or tap **Operate** to start or stop the test operation.

During the test process, the oscilloscope will test the waveforms, display the test information, and output the test information based on the current of settings. You can set the test mask, the display status of the test information, and the output form of a pass/ failed test based on the selected source channel for the test. Then save the test mask range to the internal or external memory, and then recall it when needed.

TIP



- Only when the pass/fail test function is enabled, can you start or stop the pass/fail test operation, save and recall the test mask range.
- After starting the test operation, you can neither modify the source channel nor adjust the test mask.

The "**Pass/Fail**" result will be displayed at the right side of the screen under the "**Result**" list.

16.3 To Select the Source

Click or tap the drop-down button of **Source** to select the desired source from the drop-down list. The available channels include CH1~CH4.

16.4 Mask

In the **Pass/Fail** menu, You can self-define the mask of the pass/fail test.

Create a Mask

Click or tap **Create** to self-define the mask of the pass/fail test.

Click or tap **X Mask** and **Y Mask** respectively to set the horizontal tolerance range and vertical tolerance range with the pop-up numeric keypad. Then click or tap **Create** to apply the currently created mask (the region not covered by blue within the screen).

Load a Mask

When the pass/fail test function is enabled, you can load the test mask files from the internal memory or external USB storage device (when detected) and apply them to the current pass/fail test function.

Click or tap **Load** to enter the file loading interface. Click or tap the input field of **File Path** to load the specified test mask files (in *.pf format) and apply them to the current pass/fail test function. For details, refer to descriptions in "*Disk Management*" section in "*Store and Load*".

Save a Mask

When the pass/fail test function is enabled, you can save the current test mask range to the internal memory or external USB storage device (when detected) in "*.pf" format.

Click or tap **Save** to enter the file saving interface. Click or tap the input field of **File Name** and **File Path** to input the filename and select the desired file path to save the test mask file to the internal or external memory. For details, refer to descriptions in "*Disk Management*" section in "*Store and Load*".

16.5 To Set the Output Form of the Test Results

In the **Option** menu, you can set the follow-up operations that the oscilloscope will do when test results are generated according to your needs.

Set the Output Event and PF Output

- Click or tap the ON/OFF tab for the **PF Output** to enable or disable PF output. When enabled, in the **Utility** menu, the sub-menu **PF Out** under the **Setup** menu is automatically set to "PassFail". When a successful or failed event test is detected, a pulse will be output from the **[TRIG/PF OUT]** connector. If disabled, the **PF Out** under the **Setup** menu is automatically set to "TrigOut", and the output of the **[TRIG/PF OUT]** connector is irrelevant with the pass/fail test.
- Click or tap "Pass" or "Fail" under **Output Event**.

Set the Output Polarity and Output Pulse Width

Click or tap "Positive" or "Negative" under **Polarity**, then click or tap the input field of **Pulse** to set the pulse width. Its range is from 100 ns to 10 ms. By default, it is 1 μ s.

Set the Error Action

Click or tap the check box of **Err Action** to select one operation that the oscilloscope will execute once a pass/fail test is detected.

- **Stop:** indicates stopping sampling when a pass/fail test event is found.
- **Beeper:** indicates that the beeper sounds an alarm when a failed test is found (irrelevant with the on/off status of the beeper of the instrument).
- **Screenshot:** performs the screenshot operation when a failed test is found. If an external storage device is detected, the screenshot will be saved to the external storage device directly. Otherwise, it will be saved to the local disk.

If "Screenshot" is selected, "Stop" action will be executed forcibly. The sampling will be stopped automatically. After the Screenshot operation is completed, the sampling will continue.

16.6 Display of the Statistics of the Test Results

After the "Pass/Fail" function is enabled, the test result list will be displayed at the right side of the screen. You can click or tap the icon  at the lower-right corner of the screen to hide the test result list.

The test results statistics include the number of failed frames, the number of successful frames, and total number of frames, as shown in the figure below.

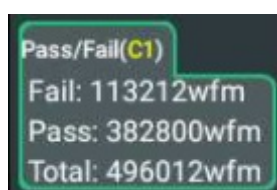

Click or tap "Pass/Fail" test result list, the following menu items can be displayed and you can perform the following operations.

- Click or tap **Reset Stat.**, then the statistics in the "Pass/Fail" test result list will be reset to 0.
- Click or tap **Setting**, then the **PassFail** setting interface is displayed.
- Click or tap **Remove**, then the pass/fail function is disabled.

17 Protocol Decoding

You can use the protocol analysis to discover errors, debug hardware, and accelerate development easily, ensuring you to accomplish the projects with high speed and good quality. Protocol decoding is the basis of protocol analysis. Only protocol analyses with correct protocol decoding are acceptable, and only correct protocol decoding can identify more error information. This oscilloscope provides four bus decoding modules (Decode 1, Decode 2, Decode 3, and Decode 4) to make common protocol decoding (including GPIO (standard), UART/RS232 (option), I2C (option), SPI (option), LIN (option), CAN (option), FlexRay (option), I2S (option), 1553B (option), USB2.0 (option)) for the input signals of the analog channels (CH1~CH4). As the decoding functions and setting methods of Decode1, Decode2, Decode3, and Decode4, this chapter takes Decode1 as an example for illustration.

- Click or tap the function navigation icon  at the lower-left corner of the screen, and then select **Decode** to enter the "Decode" menu.
- Tap the **Decode** icon on the small screen at the right side of the screen to enter the "Decode" menu.
- Click or tap the **Decode** icon at the top of the screen to enter the "Decode" menu.

To get the decoding option information, refer to descriptions in "[Appendix A: Options and Accessories](#)".

If you have purchased the decoding option, activate it according the descriptions in [To View the Option Information and the Option Installation](#).

17.1 GPIO Decoding

GPIO bus consists of clock line and data line. As shown in the figure below, CLK is the clock line, whereas Bit0 and Bit1 are the 0 bit and 1st bit on the data line respectively. The oscilloscope will sample the channel data on the rising edge, falling edge, or the rising/falling edge of the clock and judge each data point (logic "1" or logic "0") according to the preset threshold level.

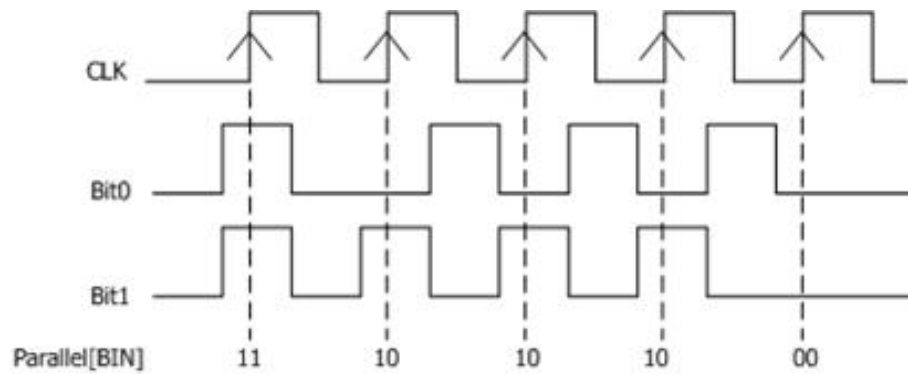

Figure 17.1 Schematic Diagram of GPIO Decoding

In the **Decode** menu, click or tap the drop-down button of **Bus Type** to select **GPIO**, then configure the parameters for GPIO decoding.

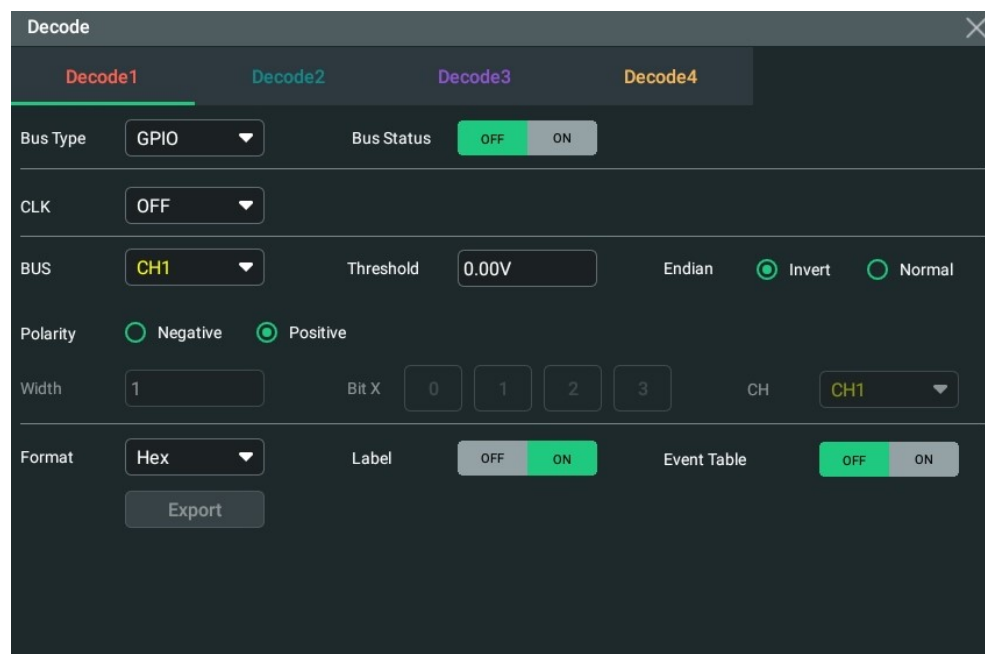

Figure 17.2 GPIO Decoding Menu

Bus Status

Click or tap the ON/OFF button for the **Bus Status** menu item to enable/disable the bus decoding.

17.1.1 Clock Setting (CLK)

Clock Setting (CLK)

Click or tap the drop-down button of **CLK** to select the desired source of the clock channel from the drop-down list. The sources include CH1~CH4. If "OFF" is selected,

no clock channel is set, and sampling is performed when a hop occurs to the data of the data channel during decoding.

Threshold

When the clock signal is an analog channel (CH1~CH4), you need to set a threshold level. Click or tap the input field of **Threshold**, and then use the pop-up numeric keypad to set the threshold. The range of the threshold is related to the current vertical scale and offset.

CLK Edge

In **CLK Edge** menu, click or tap to select to sample the channel data on the rising edge, falling edge, or both edges of the clock signal.

- **Rising:** samples the channel data on the rising edge of the clock.
- **Falling:** samples the channel data on the falling edge of the clock.
- **Both:** samples the channel data on the rising edge or the falling edge of the clock.

17.1.2 Bus Setting

Set the Bus

Click or tap drop-down button of **BUS** to select the digital bus (CH1~CH4) for Parallel decoding from the drop-down list.

Table 17.1 Bus Setting

Bus	Width	Bit X	Channel	Remarks
CH1	1	0	CH1	Width, Bit X, and CH are set automatically, and you cannot modify them.
CH2	1	0	CH2	Width, Bit X, and CH are set automatically, and you cannot modify them.
CH3	1	0	CH3	Width, Bit X, and CH are set automatically, and you cannot modify them.
CH4	1	0	CH4	Width, Bit X, and CH are set automatically, and you cannot modify them.
User	1 to 4, 1 for default	1 (Default)	CH1~CH4	Bit1 to Bit4 are set to CH1 to CH4 respectively.

Set the Threshold Level

To judge logic "1" and logic "0" of the buses, you need to set a threshold level for each analog channel (CH1~CH4). When the channel signal amplitude is greater than the preset threshold, it is judged as logic "1"; otherwise logic "0".

Click or tap the input field of **Threshold**, and then use the pop-up numeric keypad to set the threshold. The range of the threshold is related to the current vertical scale and offset.

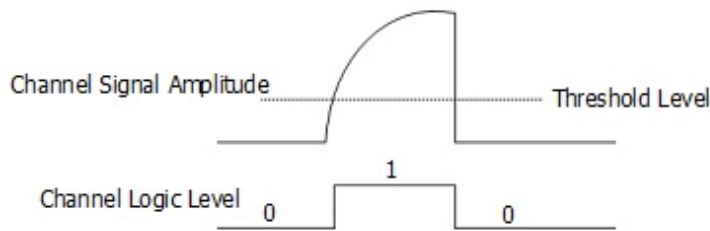

Endian

In **Endian** menu, click or tap to select "Invert" or "Normal" as the endian of the bus.

Polarity

In **Polarity** menu, click or tap to select "Positive" or "Negative" as the data polarity.

17.1.3 Display-related Setting

In **Decode** menu, set the following display-related parameters.

Set the Display Format

Click or tap the drop-down button of **Format** to select the display format of the bus data from the drop-down list. The available options include "Hex", "Dec", "Bin", or "ASCII".

Set the Label Display

Click or tap the ON/OFF tab for the **Label** menu to enable or disable the label display of the decoding bus. When enabled, the bus label will be displayed at the upper-left side of the bus (when the bus display is enabled). The label shows the current bus type.

17.1.4 Event Table

The event table displays the decoded data and the corresponding decoding information in time order in the form of a table. It can be used to observe relatively longer decoded data. The decoding information includes the decoded data, the corresponding line number, and time information.

Open or Close the Event Table

Click or tap the ON/OFF tab for the **Event Table** menu to enable or disable the display of the event table. When enabled, the following event table is displayed, as

shown in the figure below. You can also click or tap the icon  at the upper-right corner of the table to close the event table.



Figure 17.3 Parallel Decoding Event Table



TIP

- When you adjust the horizontal time base, the waveform displayed on the screen will also change, and the total number of lines containing the decoding information in the event table will also be changed.
- The displayed decoded data information in the bus is related to the value of the horizontal time base. Reducing the horizontal time base can help you view the detailed information.

Export

When the operating status of the instrument is STOP, you can export the time and corresponding decoding data from the current event table.

Click or tap **Export**, save setting interface is displayed. You can export the data list to the internal memory or the external USB storage device (when detected) in "*.csv" format. For detailed saving operation, refer to descriptions in [Storage](#).

17.2 UART/RS232 Decoding (Option)

UART/RS232 serial bus consists of the transmitting data line (TX) and the receiving data line (RX).

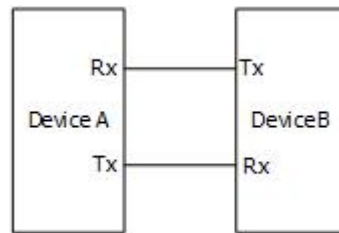

Figure 17.4 Schematic Diagram of UART/RS232 Serial Bus

The industry standard of UART/RS232 uses "Negative Logic", that is, high level is logic "0" and low level is logic "1".

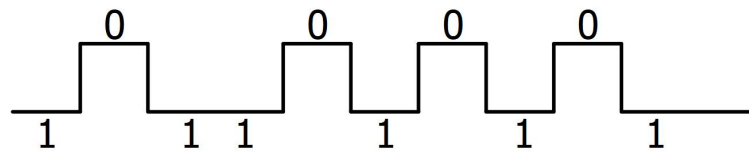
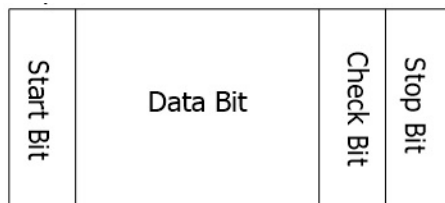

Figure 17.5 Schematic Diagram of Negative Logic

In UART/RS232, baud rate is used to represent the transmission rate (namely bits per second) of the data. You need to set the start bit, data bits, check bit (optional), and stop bits for each frame of data.



- **Start Bit:** indicates when to output data.
- **Data Bit:** indicates the number of data bits actually contained in each frame of data.
- **Check Bit:** used to check whether the data are properly transmitted.
- **Stop Bit:** indicates when to stop outputting data.

In the **Decode** menu, click or tap the drop-down button of **Bus Type** to select **UART/RS232**, then configure the parameters for UART/RS232 decoding.

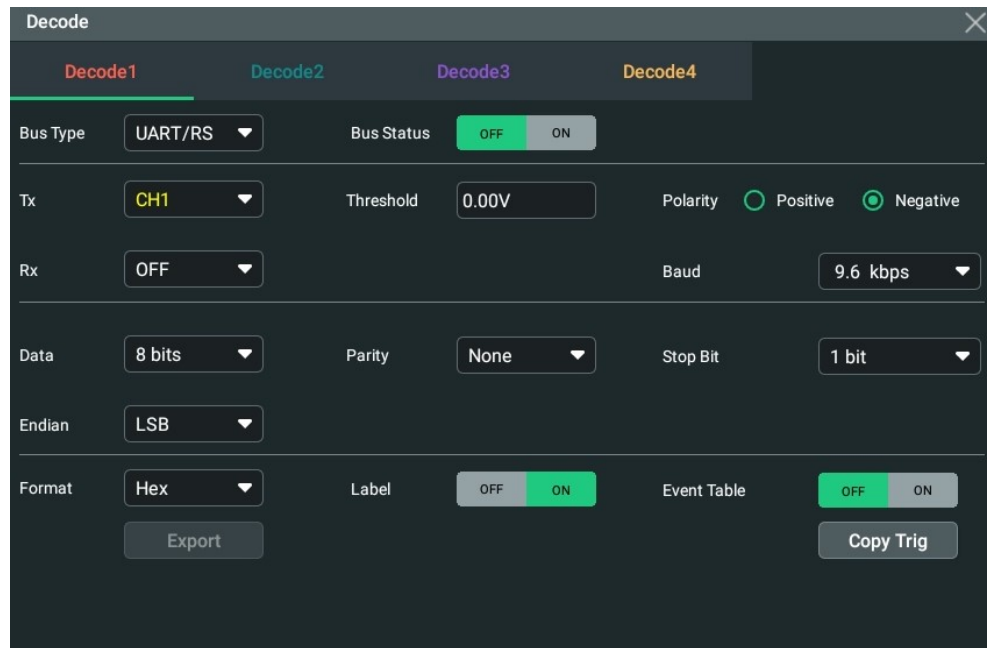

Figure 17.6 UART/RS232 Decoding Menu

Click or tap the ON/OFF button for the **Bus Status** menu item to enable/disable the bus decoding.

Quickly Apply Trigger Settings to Decoding

Copy trig indicates applying the trigger settings to the specified decoding setting.

Click or tap **Copy Trig** to apply the trigger settings to the specified decoding setting.

17.2.1 Source Setting

Set the Tx source and the threshold

Click or tap drop-down button of **Tx** to select the desired source from the drop-down list. The sources include CH1~CH4.

Click or tap the input field of **Threshold**, and then use the pop-up numeric keypad to set the threshold of Tx source. The range value is from -5.00 V to 5.00 V. Its default value is 0 V.

When you modify the threshold of the Tx source channel, a dotted line displaying the current threshold level is displayed on the screen. It disappears in about 2 s after you stop modifying the threshold.

Set the Rx source and the threshold

Use the same method to select the **Rx** source and set the threshold. The default state of **Rx** is OFF.

Polarity

Click or tap "Positive" or "Negative" under **Polarity**.

- **Positive:** Uses negative logic. High level is logic "0" and low level is logic "1".
- **Negative:** Uses positive logic. High level is logic "1" and low level is logic "0".

Set the Baud Rate

Click or tap the drop-down button of **Baud** to select the preset baud rate from the drop-down list. The available baud rates include 50 bps, 75 bps, 110 bps, 134 bps, 150 bps, and etc.

The oscilloscope supports users to self-define the baud rate. Click or tap the drop-down button of **Baud** to select "User" from the drop-down list. Then set the baud rate with the pop-up numeric keypad.

17.2.2 To Set Data Package

Data Bits

Click or tap the drop-down button of **Data** to select the data bits from the drop-down list. The available data bits are 5 bits, 6 bits, 7 bits, 8 bits, and 9 bits.

Parity

It is used to check whether the data transmission is correct. Click or tap the drop-down button of **Parity** to select the desired parity mode.

- **None:** indicates that no check bit appears during the transmission.
- **Even:** indicates that the total number of "1" in the data bit and check bit is an even number. For example, when 0x55 (01010101) is sent, "0" should be added to the check bit.
- **Odd:** indicates that the total number of "1" in the data bit and check bit is an odd number. For example, when 0x55 (01010101) is sent, "1" should be added to the check bit.

Stop Bit

Click or tap the drop-down button of **Stop Bit** to set the stop bits after each frame of data. It can be set to 1 bit, 1.5 bits, or 2 bits.

Endian

Click or tap the drop-down button of **Endian** to select the desired endian.

- **LSB:** indicates Least Significant Bit transmission sequence, i.g. the lowest bit of the data is transmitted first.

- **MSB:** indicates Most Significant Bit transmission sequence, i.g. the highest bit of the data is transmitted first.

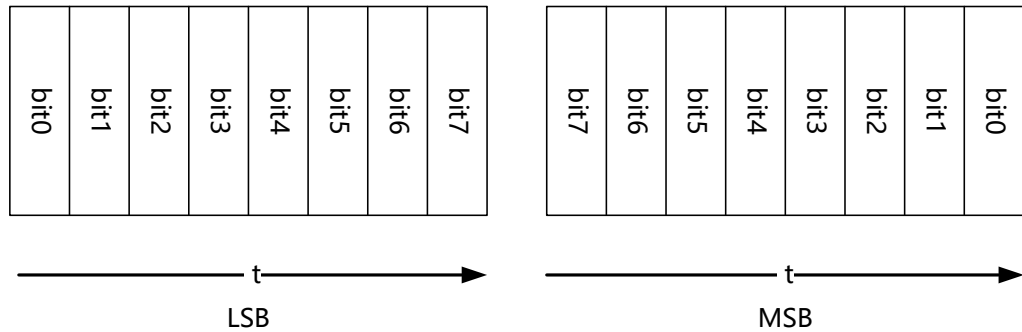

17.2.3 Display-related Setting

In **Decode** menu, set the following display-related parameters.

Set the Display Format

Click or tap the drop-down button of **Format** to select the display format of the bus data from the drop-down list. The available options include "**Hex**", "**Dec**", "**Bin**", or "**ASCII**".

Set the Label Display

Click or tap the ON/OFF tab for the **Label** menu to enable or disable the label display of the decoding bus. When enabled, the bus label will be displayed at the upper-left side of the bus (when the bus display is enabled). The label shows the current bus type.

17.2.4 Event Table

Click or tap the ON/OFF tab for the **Event Table** menu to enable or disable the display of the event table. When enabled, the following event table is displayed, as

shown in the figure below. You can also click or tap the icon  at the upper-right corner of the table to close the event table.

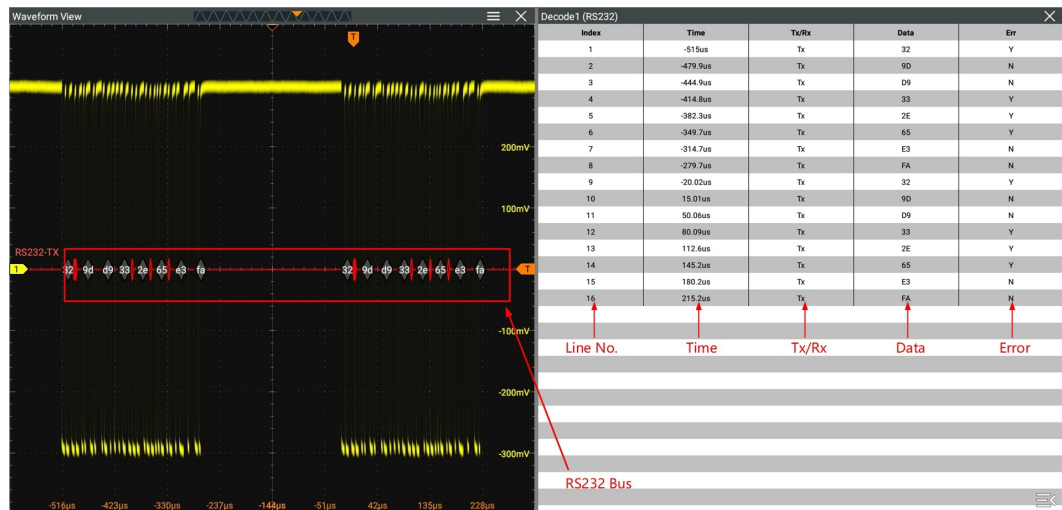

Figure 17.7 UART/RS232 Decoding Event Table

**TIP**

- When you adjust the horizontal time base, the waveform displayed on the screen will also change, and the total number of lines containing the decoding information in the event table will also be changed.
- The displayed decoded data information in the bus is related to the value of the horizontal time base. Reducing the horizontal time base can help you view the detailed information.

Export

When the operating status of the instrument is STOP, you can export the time and corresponding decoding data from the current event table.

Click or tap **Export**, save setting interface is displayed. You can export the data list to the internal memory or the external USB storage device (when detected) in "*.csv" format. For detailed saving operation, refer to descriptions in *Storage*.

17.3 I2C Decoding (Option)

I2C serial bus consists of the clock line (SCL) and the data line (SDA).

SCL: samples SDA on the of rising or falling edge of the clock.

SDA: indicates the data channel.

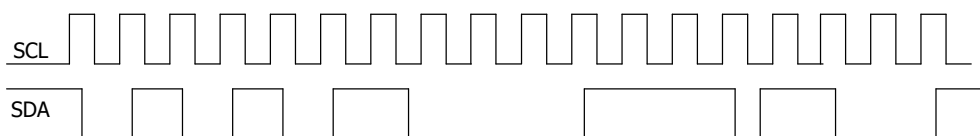

Figure 17.8 I2C Serial Bus

In the **Decode** menu, click or tap the drop-down button of **Bus Type** to select **I2C**, then configure the parameters for I2C decoding.

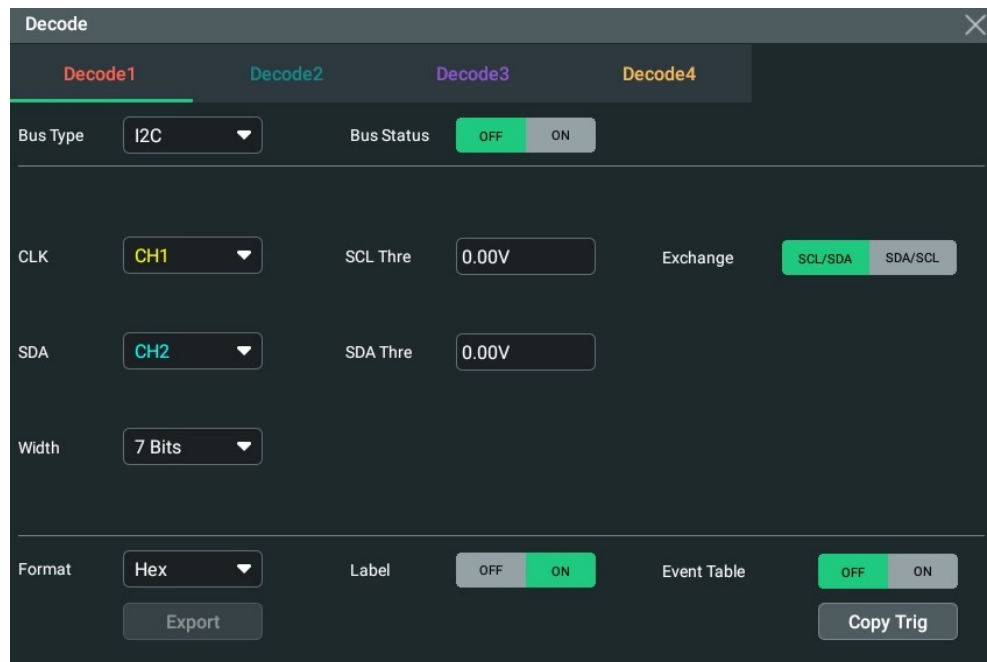

Figure 17.9 I2C Decoding Menu

Bus Status

Click or tap the ON/OFF button for the **Bus Status** menu item to enable/disable the bus decoding.

Quickly Apply Trigger Settings to Decoding

Copy trig indicates applying the trigger settings to the specified decoding setting.

Click or tap **Copy Trig** to apply the trigger settings to the specified decoding setting.

17.3.1 Source Setting

Set the Clock Channel Source and the Threshold

- Click or tap the drop-down button of **CLK** to select the desired source of the clock channel (CH1~CH4) from the drop-down list.
- Click or tap the input field of **SCL Thre**, and then use the pop-up numeric keypad to set the threshold of the clock channel.

When you modify the threshold of the clock channel, a dotted line displaying the current threshold level is displayed on the screen. It disappears in about 2 s after you stop modifying the threshold.

Set the Data Channel Source and the Threshold

- Click or tap the drop-down button of **SDA** to select the desired source of the data channel (CH1~CH4) from the drop-down list.
- Click or tap the input field of **SDA Thre**, and then use the pop-up numeric keypad to set the threshold of the data channel.

Exchange Sources

Click or tap "SCL/SDA" or "SDA/SCL" under **Exchange** to exchange the sources of the current clock channel and data channel.

Set the Address Width

Click or tap the drop-down button of **Width** to select the address width. The available choices are "7 Bits", "8 Bits", and "10 Bits". When "7 Bits" is selected, R/W bit is not included in the address. When "8 Bits" or "10 Bits" is selected, R/W bit is included in the address.

- **7:** In 7-bit addressing, after the START condition, a slave address is sent. The address starts to transfer from the first byte, as shown in the figure below. The first seven bits of the first byte make up the slave address, and the eighth bit is the LSB (least significant bit) which determines the direction of the message, also called a data direction bit (R/W). A "zero" indicates a transmission (WRITE), a "one" indicates a request for data (READ).

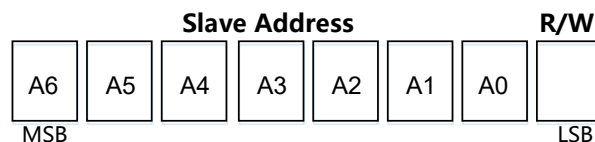

- **8:** same as the 7-bit addressing. A R/W bit is included in the 8-bit addressing for the slave address.
- **10:** 10-bit addressing is compatible with, and can be combined with, 7-bit addressing. As shown in the figure below, in 10-bit addressing, the first byte is the special reserved address 10-bit Address Indicator to indicate the current 10-bit address that is transferring.

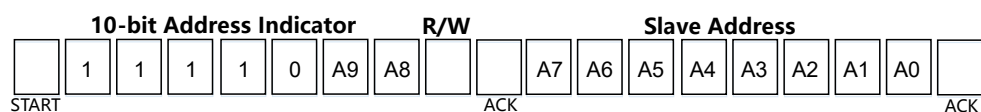

17.3.2 Display-related Setting

In **Decode** menu, set the following display-related parameters.

Set the Display Format

Click or tap the drop-down button of **Format** to select the display format of the bus data from the drop-down list. The available options include "Hex", "Dec", "Bin", or "ASCII".

Set the Label Display

Click or tap the ON/OFF tab for the **Label** menu to enable or disable the label display of the decoding bus. When enabled, the bus label will be displayed at the upper-left side of the bus (when the bus display is enabled). The label shows the current bus type.

17.3.3 Event Table

Open or Close the Event Table

Click or tap the ON/OFF tab for the **Event Table** menu to enable or disable the display of the event table. When enabled, the following event table is displayed, as shown in the figure below. You can also click or tap the icon  at the upper-right corner of the table to close the event table.



Figure 17.10 I2C Decoding Event Table



TIP

- When you adjust the horizontal time base, the waveform displayed on the screen will also change, and the total number of lines containing the decoding information in the event table will also be changed.

- The displayed decoded data information in the bus is related to the value of the horizontal time base. Reducing the horizontal time base can help you view the detailed information.

Export

When the operating status of the instrument is STOP, you can export the time and corresponding decoding data from the current event table.

Click or tap **Export**, save setting interface is displayed. You can export the data list to the internal memory or the external USB storage device (when detected) in "*.csv" format. For detailed saving operation, refer to descriptions in *Storage*.

Address information in decoding

For I2C bus, each frame of data starts with the address information (read address and write address). In the address information, "Read" indicates the read address



and "Write" indicates the write address (



). You can decide whether to include or exclude the "R/W" bit for the address information.

Error expressions in decoding

In I2C decoding, when ACK (acknowledgment) is 1, ACK error occurs. When the

detected ACK is 1, red error report information  (the display form is related to the value of the horizontal time base) is displayed.

17.4 SPI Decoding (Option)

SPI bus is based on the master— slave configuration and usually consists of chip select line (CS), clock line (CLK), and data line (SDA). Wherein, the data lines include the master input/slave output (MISO) data line and master output/slave input (MOSI) data line. The oscilloscope samples the channel data on the rising or falling edge of the clock signal (if the source is an analog channel, the oscilloscope will also judge each data point (logic "1" or logic "0") according to the preset threshold level).

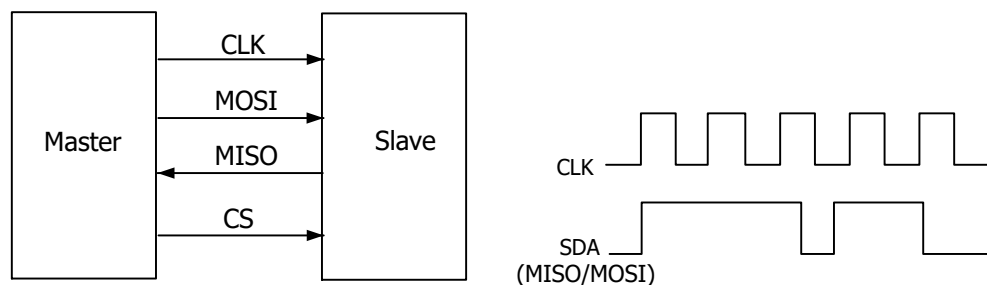

Figure 17.11 SPI Serial Bus

In the **Decode** menu, click or tap the drop-down button of **Bus Type** to select **SPI**, then configure the parameters for SPI decoding.

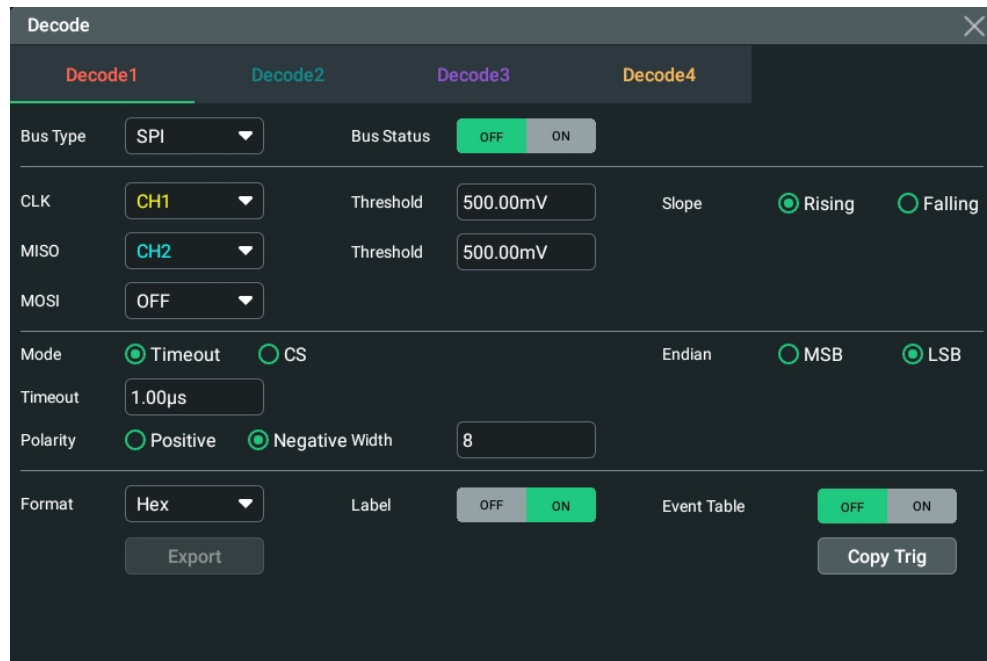

Figure 17.12 SPI Decoding Menu

Bus Status

Click or tap the ON/OFF button for the **Bus Status** menu item to enable/disable the bus decoding.

Quickly Apply Trigger Settings to Decoding

Copy trig indicates applying the trigger settings to the specified decoding setting.

Click or tap **Copy Trig** to apply the trigger settings to the specified decoding setting.

17.4.1 To Set the Source

Set the Clock Signal

- Click or tap the drop-down button of **CLK** to select the desired source of the clock channel from the drop-down list. The sources include CH1~CH4.
- Click or tap the input field of **Threshold** at the right side of the **CLK** menu, and then use the pop-up numeric keypad to set the threshold of the clock channel.
- Click or tap "**Rising**" or "**Falling**" under **Slope** to set the instrument to sample MISO and MOSI on the CLK.

Set MISO and MOSI

- Click or tap drop-down button of **MISO** to select the desired source of MISO from the drop-down list. The sources include CH1~CH4 and OFF.
- Click or tap the input field of **Threshold** at the right side of **MISO**, and then use the pop-up numeric keypad to set the threshold of the MISO channel.

- Click or tap drop-down button of **MOSI** to select the desired source of MOSI from the drop-down list. The sources include CH1~CH4 and OFF.

**TIP**

The source channels of MISO and MOSI cannot be set to "OFF" at the same time.

17.4.2 To Set Mode and Data

Mode

Click or tap "Timeout" or "CS" under **Mode**.

- **Timeout:**

you can perform frame synchronization according to the timeout, and the timeout value must be greater than half of the clock cycle. Click or tap the input field of **Timeout**, and then use the pop-up numeric keypad to set the timeout value. The adjustable range of the timeout value is from 8 ns to 10 s. By default, it is 1 μ s.

- **CS:**

contains a chip select line (CS). You can perform frame synchronization according to CS. When "CS" is selected,

- Click or tap drop-down button of **CS** to select the desired source from the drop-down list. The sources include CH1-CH4.
- Click or tap the input field for the **Threshold** menu item to set the threshold with the pop-up numeric keypad.
- In **CS Polarity** menu, click or tap to select "**Positive**" or "**Negative**".

Endian

Click or tap the drop-down button of **Endian** to select the desired endian.

- **LSB:** indicates Least Significant Bit transmission sequence, i.g. the lowest bit of the data is transmitted first.
- **MSB:** indicates Most Significant Bit transmission sequence, i.g. the highest bit of the data is transmitted first.

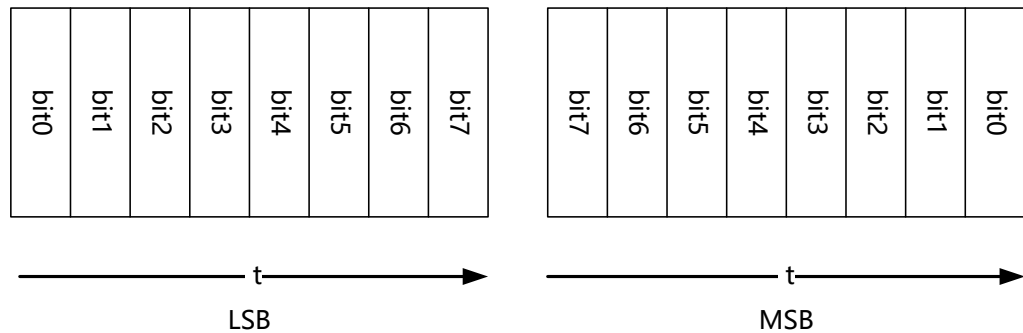

Polarity

In **Polarity** menu, click or tap to select "**Positive**" or "**Negative**".

Width Setting

Click or tap the input field of **Width**, and then use the pop-up numeric keypad to set the bits of each frame of data. The setting range is from 4 to 32. By default, it is 8.

17.4.3 Display-related Setting

In **Decode** menu, set the following display-related parameters.

Set the Display Format

Click or tap the drop-down button of **Format** to select the display format of the bus data from the drop-down list. The available options include "**Hex**", "**Dec**", "**Bin**", or "**ASCII**".

Set the Label Display

Click or tap the ON/OFF tab for the **Label** menu to enable or disable the label display of the decoding bus. When enabled, the bus label will be displayed at the upper-left side of the bus (when the bus display is enabled). The label shows the current bus type.

17.4.4 Event Table

Open or Close the Event Table

Click or tap the ON/OFF tab for the **Event Table** menu to enable or disable the display of the event table. When enabled, the following event table is displayed, as shown in the figure below. You can also click or tap the icon  at the upper-right corner of the table to close the event table.



Figure 17.13 SPI Decoding Event Table



TIP

- When you adjust the horizontal time base, the waveform displayed on the screen will also change, and the total number of lines containing the decoding information in the event table will also be changed.
- The displayed decoded data information in the bus is related to the value of the horizontal time base. Reducing the horizontal time base can help you view the detailed information.

Export

When the operating status of the instrument is STOP, you can export the time and corresponding decoding data from the current event table.

Click or tap **Export**, save setting interface is displayed. You can export the data list to the internal memory or the external USB storage device (when detected) in "*.csv" format. For detailed saving operation, refer to descriptions in *Storage*.

17.5 LIN Decoding (Option)

The oscilloscope samples the LIN signal, and judges each data point to be logic "1" or logic "0" according to the preset threshold level. The LIN decoding is required to specify the LIN signal protocol version.

In the **Decode** menu, click or tap the drop-down button of **Bus Type** to select **LIN**, then configure the parameters for LIN decoding.

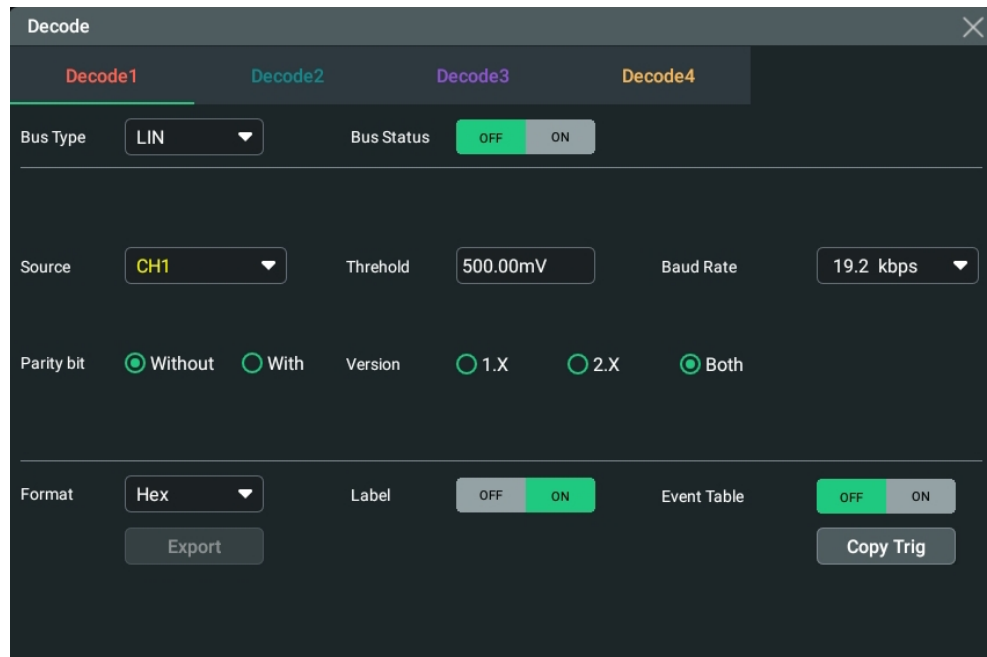

Figure 17.14 LIN Decoding Menu

Bus Status

Click or tap the ON/OFF button for the **Bus Status** menu item to enable/disable the bus decoding.

Quickly Apply Trigger Settings to Decoding

Copy trig indicates applying the trigger settings to the specified decoding setting.

Click or tap **Copy Trig** to apply the trigger settings to the specified decoding setting.

17.5.1 To Configure the Signal

Set the Source and the Threshold

- Click or tap drop-down button of **Source** to select the desired source from the drop-down list. The sources include CH1~CH4.
- Click or tap the input field of **Threshold**, and then use the pop-up numeric keypad to set the threshold of the source channel.

When you modify the threshold of the clock channel, a dotted line displaying the current threshold level is displayed on the screen. It disappears in about 2 s after you stop modifying the threshold.

Set the Signal

- Click or tap the drop-down button of **Baud Rate** from the drop-down list. The available baud rates include 2.4 kbps, 4.8 kbps, 9.6 kbps, 10.0 kbps, 19.2 kbps, and etc.

- In **Parity bit** menu, click or tap **"With"** or **"Without"** to select whether the data contain the parity bit.
- In **Version** menu, select the protocol version that matches the LIN bus signal. The available versions include **"1.X"**, **"2.X"**, and **"Both"**.

17.5.2 Display-related Setting

In **Decode** menu, set the following display-related parameters.

Set the Display Format

Click or tap the drop-down button of **Format** to select the display format of the bus data from the drop-down list. The available options include **"Hex"**, **"Dec"**, **"Bin"**, or **"ASCII"**.

Set the Label Display

Click or tap the ON/OFF tab for the **Label** menu to enable or disable the label display of the decoding bus. When enabled, the bus label will be displayed at the upper-left side of the bus (when the bus display is enabled). The label shows the current bus type.

17.5.3 Event Table

Open or Close the Event Table

Click or tap the ON/OFF tab for the **Event Table** menu to enable or disable the display of the event table. When enabled, the following event table is displayed, as

shown in the figure below. You can also click or tap the icon  at the upper-right corner of the table to close the event table.

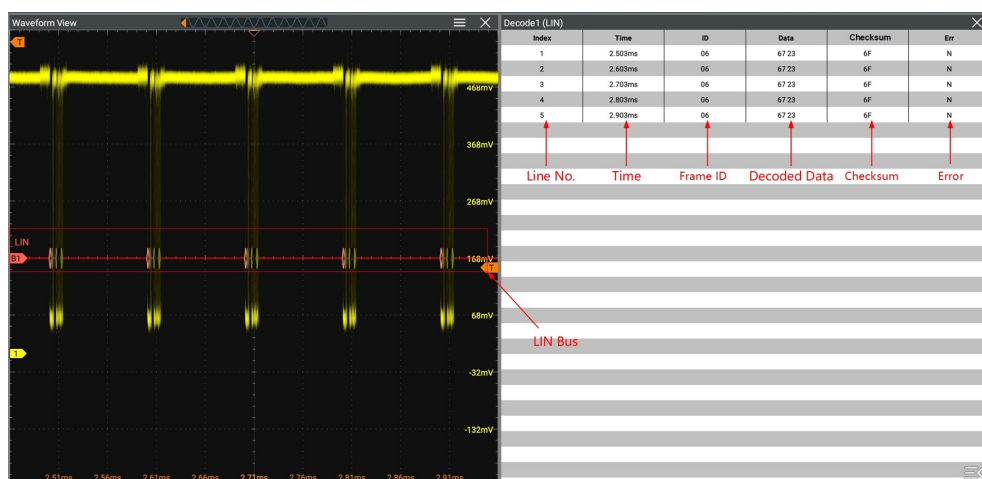

Figure 17.15 LIN Decoding Event Table

**TIP**

- When you adjust the horizontal time base, the waveform displayed on the screen will also change, and the total number of lines containing the decoding information in the event table will also be changed.
- The displayed decoded data information in the bus is related to the value of the horizontal time base. Reducing the horizontal time base can help you view the detailed information.

Export

When the operating status of the instrument is STOP, you can export the time and corresponding decoding data from the current event table.

Click or tap **Export**, save setting interface is displayed. You can export the data list to the internal memory or the external USB storage device (when detected) in "*.csv" format. For detailed saving operation, refer to descriptions in *Storage*.

Interpret the Decoded LIN Data

- Break (Sync Break): expressed in Hex, identified as "Break:".
- SYNC (Sync): expressed in Hex, identified as "SYNC:".
- ID (Frame ID): expressed in Hex, identified as "ID:".
- Data (Data): Its display format is the same as that of the bus data (Hex, Dec, Bin, or ASCII), identified as "Data:".
- Checksum: expressed in Hex, identified as "Checksum:". When error occurs, it is displayed as a red patch.
- Wakeup (wake up symbol): identified as "Wakeup:".

17.6 CAN Decoding (Option)

The oscilloscope samples the CAN or CAN-FD signal at the specified sample position, and judges each data point to be logic "1" or logic "0" according to the preset threshold level. You need to specify the CAN or CAN-FD signal type and sample position for CAN decoding.

In the **Decode** menu, click or tap the drop-down button of **Bus Type** to select **CAN**, then configure the parameters for CAN decoding.

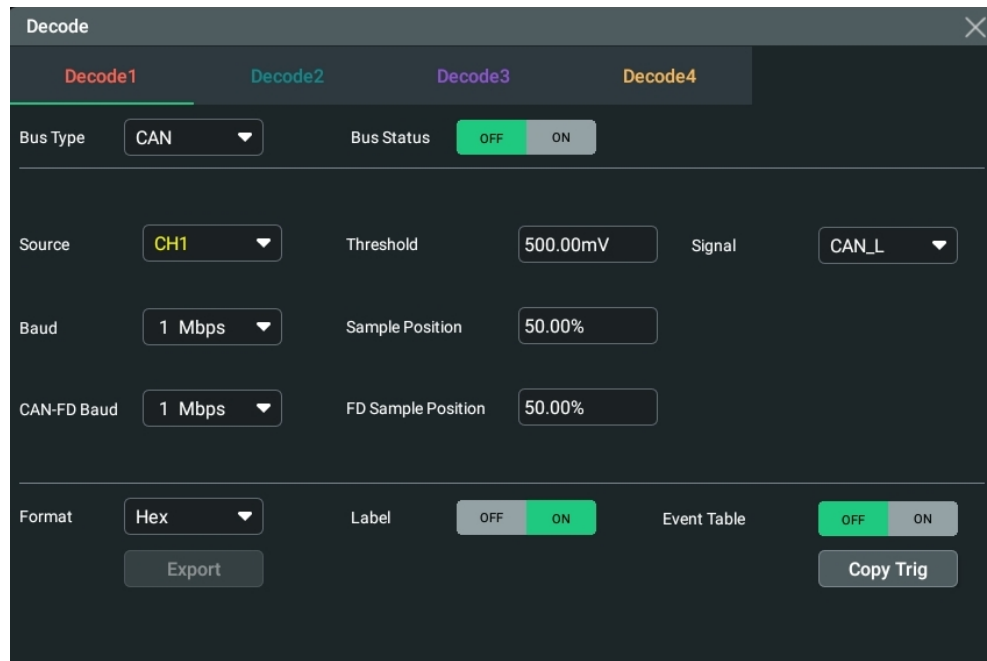

Figure 17.16 CAN Decoding Menu

Bus Status

Click or tap the ON/OFF button for the **Bus Status** menu item to enable/disable the bus decoding.

Quickly Apply Trigger Settings to Decoding

Copy trig indicates applying the trigger settings to the specified decoding setting.

Click or tap **Copy Trig** to apply the trigger settings to the specified decoding setting.

17.6.1 To Configure the Signal

Set the Source and the Threshold

- Click or tap drop-down button of **Source** to select the desired source from the drop-down list. The sources include CH1~CH4.
- Click or tap the input field of **Threshold**, and then use the pop-up numeric keypad to set the threshold of the source channel.

When you modify the threshold of the clock channel, a dotted line displaying the current threshold level is displayed on the screen. It disappears in about 2 s after you stop modifying the threshold.

Select the Signal Type

Click or tap the drop-down button of **Signal** to select a signal type that matches the CAN bus signal. The available signal types include CAN_H, CAN_L, Rx, Tx, and Diff.

- **CAN_H**: indicates the actual CAN_H bus signal.
- **CAN_L**: indicates the actual CAN_L bus signal.
- **Rx**: indicates the Receive signal from the CAN bus transceiver.
- **Tx**: indicates the Transmit signal from the CAN bus transceiver.
- **DIFF**: The CAN differential bus signals connected to an analog source channel by using a differential probe. Connect the differential probe's positive lead to the CAN_H bus signal and connect the negative lead to the CAN_L bus signal.

Specify the Standard Signal Rate

Click or tap the drop-down button of **Baud** to select the preset baud rate from the drop-down list. The available baud rates include 10.0 kbps, 19.2 kbps, 20.0 kbps, 33.3 kbps, 38.4 kbps, 50.0 kbps, and etc.

Sample Position

Sample position is a point within a bit's time. The oscilloscope samples the bit level at this point. The sample position is represented by the proportion of "the time from the start of the bit to the sample point" to the "bit time", as shown in the figure below.

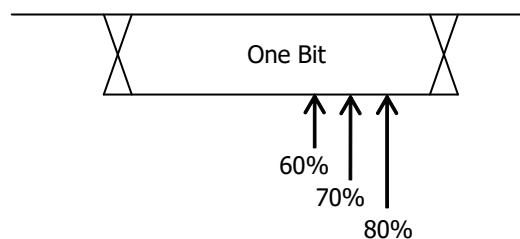

Figure 17.17 Sample Position

Click or tap the input field of **Sample Position** to set it by using the pop-up numeric keypad. The settable range is from 10% to 90%.

Set the CAN-FD Baud

CAN-FD baud is a dedicated parameter configured for the CAN-FD decoding. Click or tap the drop-down button of **CAN-FD Baud** to select the variable baud rate from the drop-down list. The available baud rates include 1 Mbps, 2 Mbps, 3 Mbps, 4 Mbps, and etc.

Set the FD Sample Position

FD sample position is a dedicated parameter configured for the CAN-FD decoding. Click or tap the input field of **FD Sample Position** to set it by using the pop-up numeric keypad. The settable range is from 10% to 90%.

17.6.2 Display-related Setting

In **Decode** menu, set the following display-related parameters.

Set the Display Format

Click or tap the drop-down button of **Format** to select the display format of the bus data from the drop-down list. The available options include "Hex", "Dec", "Bin", or "ASCII".

Set the Label Display

Click or tap the ON/OFF tab for the **Label** menu to enable or disable the label display of the decoding bus. When enabled, the bus label will be displayed at the upper-left side of the bus (when the bus display is enabled). The label shows the current bus type.

17.6.3 Event Table

Open or Close the Event Table

Click or tap the ON/OFF tab for the **Event Table** menu to enable or disable the display of the event table. When enabled, the following event table is displayed, as

shown in the figure below. You can also click or tap the icon  at the upper-right corner of the table to close the event table.

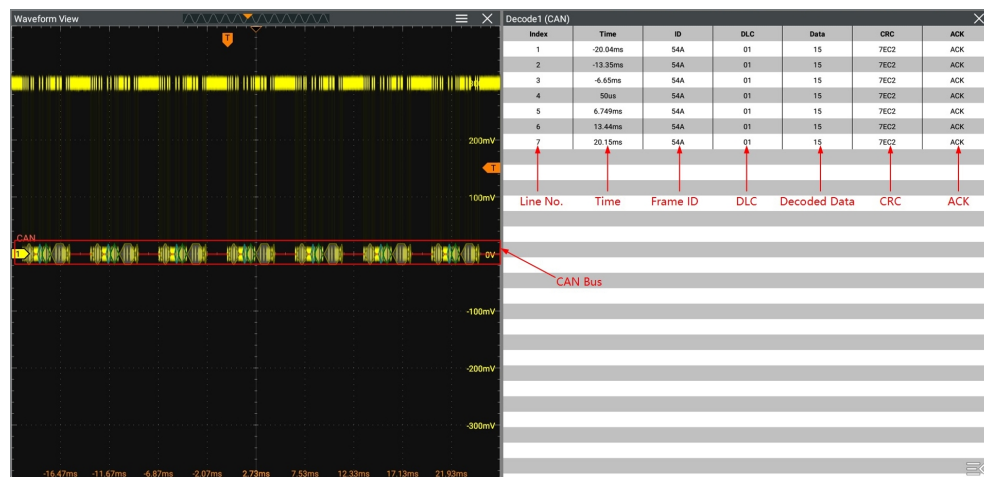

Figure 17.18 CAN Decoding Event Table



TIP

- When you adjust the horizontal time base, the waveform displayed on the screen will also change, and the total number of lines containing the decoding information in the event table will also be changed.

- The displayed decoded data information in the bus is related to the value of the horizontal time base. Reducing the horizontal time base can help you view the detailed information.

Export

When the operating status of the instrument is STOP, you can export the time and corresponding decoding data from the current event table.

Click or tap **Export**, save setting interface is displayed. You can export the data list to the internal memory or the external USB storage device (when detected) in "*.csv" format. For detailed saving operation, refer to descriptions in *Storage*.

Interpret the Decoded CAN Data

- Frame ID: expressed in Hex, identified as "ID:".
- DLC (Data Length Code): expressed in Hex, identified as "DLC:".
- Data: Its display format is the same as that of the bus data (Hex, Dec, Bin, or ASCII), identified as "Data:".
- CRC (Cyclic Redundancy Check): expressed in Hex, identified as "CRC:".
- ACK (Acknowledgement): identified as "ACK". When errors (ACK is detected to be 1) occur, displayed as a red patch.
- R (remote frame): identified as "R:".
- Stuff (Bit filling error): identified as "Stuff".

17.7 FlexRay Decoding (Option)

FlexRay is a type of differential serial bus configured with three consecutive segments (i.g. packet header, payload, and packet trailer). The oscilloscope samples the FlexRay signal at the specified sample position and judges each data point as logic "1" or logic "0" according to the preset threshold level. The FlexRay decoding is required to specify the signal type and baud rate.

In the **Decode** menu, click or tap the drop-down button of **Bus Type** to select **FlexRay**, then configure the parameters for FlexRay decoding.

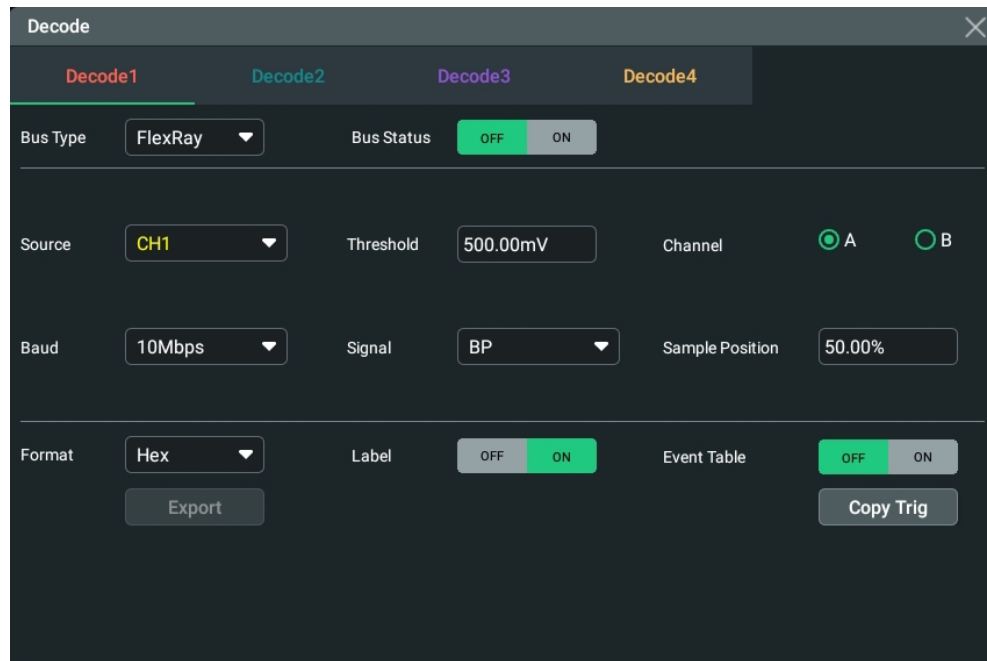

Figure 17.19 FlexRay Decoding Menu

Bus Status

Click or tap the ON/OFF button for the **Bus Status** menu item to enable/disable the bus decoding.

Quickly Apply Trigger Settings to Decoding

Copy trig indicates applying the trigger settings to the specified decoding setting.

Click or tap **Copy Trig** to apply the trigger settings to the specified decoding setting.

17.7.1 Signal Configuration

Set the Source and the Threshold

- Click or tap drop-down button of **Source** to select the desired source from the drop-down list. The sources include CH1~CH4.
- Click or tap the input field of **Threshold**, and then use the pop-up numeric keypad to set the threshold of the source channel.

When you modify the threshold of the clock channel, a dotted line displaying the current threshold level is displayed on the screen. It disappears in about 2 s after you stop modifying the threshold.

Select the Signal

Click or tap "A" or "B" under **Channel** to select a channel that matches the actual FlexRay bus signal.

Specify the Signal Rate

Click or tap the drop-down button **Baud** to select a FlexRay baud rate that matches the FlexRay bus signal. The available baud rate includes "2.5 Mbps", "5 Mbps", and "10 Mbps".

Set the Signal Type

Click or tap the drop-down button **Signal** to select a signal type that matches the actual FlexRay bus signal. The available signal types include "BP", "BM", and "RX/TX".

Sample Position

Sample position is a point within a bit's time. The oscilloscope samples the bit level at this point. The sample position is represented by the proportion of "the time from the start of the bit to the sample point" to the "bit time", as shown in the figure below.

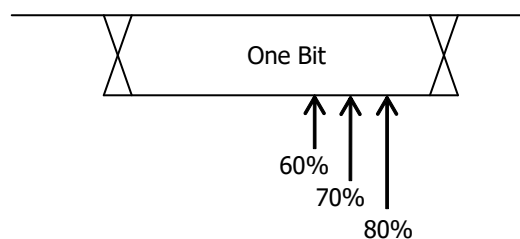

Figure 17.20 Sample Position

Click or tap the input field of **Sample Position** to set it by using the pop-up numeric keypad. The settable range is from 10% to 90%.

17.7.2 Display-related Setting

In **Decode** menu, set the following display-related parameters.

Set the Display Format

Click or tap the drop-down button of **Format** to select the display format of the bus data from the drop-down list. The available options include "Hex", "Dec", "Bin", or "ASCII".

Set the Label Display

Click or tap the ON/OFF tab for the **Label** menu to enable or disable the label display of the decoding bus. When enabled, the bus label will be displayed at the upper-left side of the bus (when the bus display is enabled). The label shows the current bus type.

17.7.3 Event Table

Open or Close the Event Table

Click or tap the ON/OFF tab for the **Event Table** menu to enable or disable the display of the event table. When enabled, the following event table is displayed, as shown in the figure below. You can also click or tap the icon  at the upper-right corner of the table to close the event table.

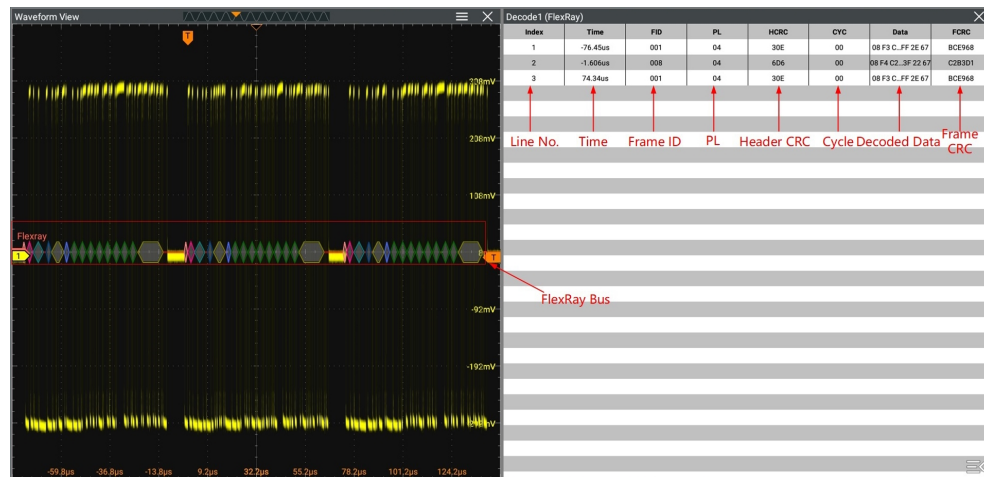

Figure 17.21 FlexRay Decoding Event Table



TIP

- When you adjust the horizontal time base, the waveform displayed on the screen will also change, and the total number of lines containing the decoding information in the event table will also be changed.
- The displayed decoded data information in the bus is related to the value of the horizontal time base. Reducing the horizontal time base can help you view the detailed information.

Export

When the operating status of the instrument is STOP, you can export the time and corresponding decoding data from the current event table.

Click or tap **Export**, save setting interface is displayed. You can export the data list to the internal memory or the external USB storage device (when detected) in "*.csv" format. For detailed saving operation, refer to descriptions in *Storage*.

Interpret the decoded FlexRay frame data

- TSS: transmission start sequence, identified as "TSS:".
- Sync Frame: identified as "SYNC:".
- ID (Frame ID): expressed in Hex, identified as "ID:".

- PL (Payload Length): expressed in Hex, identified as "PL:".
- HCRC (Header Cyclic Redundancy Check): expressed in Hex, identified as "HCRC:". When error occurs, it is displayed as a red patch.
- CYC (Cycle Number): expressed in Hex, identified as "CYC:".
- Data: Its display format is the same as that of the bus data (Hex, Dec, Bin, or ASCII), identified as "Data:".
- TCRC (Header Cyclic Redundancy Check): expressed in Hex, identified as "TCRC:". When error occurs, it is displayed as a red patch.

17.8 I2S Decoding (Option)

The oscilloscope samples the I2S signal, and judges each data point to be logic "1" or logic "0" according to the preset threshold level. I2S decoding is required to specify the serial clock, channel signal, and the data's source channel. You need to set Alignment, WS Low, and other parameters.

In the **Decode** menu, click or tap the drop-down button of **Bus Type** to select **I2S**, then configure the parameters for I2S decoding.

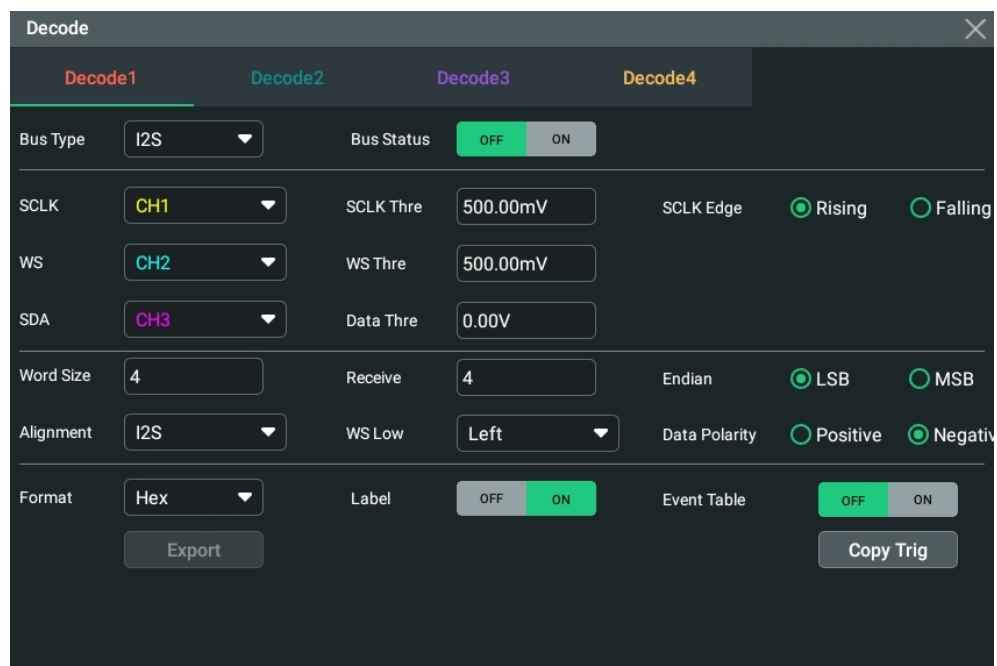

Figure 17.22 I2S Decoding Menu

Bus Status

Click or tap the ON/OFF button for the **Bus Status** menu item to enable/disable the bus decoding.

Quickly Apply Trigger Settings to Decoding

Copy trig indicates applying the trigger settings to the specified decoding setting.

Click or tap **Copy Trig** to apply the trigger settings to the specified decoding setting.

17.8.1 Source Setting

Set the SCLK Source and Threshold

- Click or tap the drop-down button of **SCLK** to select the desired channel (CH1~CH4) from the drop-down list as the serial clock source.
- Click or tap the input field of **SCLK Thre**, and then use the pop-up numeric keypad to set the threshold of the SCLK. When you modify the threshold of the clock channel, a dotted line displaying the current threshold level is displayed on the screen. It disappears in about 2 s after you stop modifying the threshold.
- In **SCLK Edge** menu, click or tap to select "Rising" or "Falling" as the desired clock edge.

Set the WS Source and Threshold

- Click or tap the drop-down button of **WS** to select the desired channel (CH1~CH4) from the drop-down list as the WS source.
- Click or tap the input field of **WS Thre**, and then use the pop-up numeric keypad to set the threshold of the WS signal. When you modify the WS threshold, a dotted line displaying the current threshold level is displayed on the screen. It disappears in about 2 s after you stop modifying the threshold.

Set the SDA Source and Threshold

- Click or tap the drop-down button of **SDA** to select the desired SDA source (CH1~CH4) from the drop-down list.
- Click or tap the input field of **Data Thre**, and then use the pop-up numeric keypad to set the threshold of the data signal. When you modify the data threshold, a dotted line displaying the current threshold level is displayed on the screen. It disappears in about 2 s after you stop modifying the threshold.

17.8.2 Bus Setting

Set the Word Size

Click or tap the input field of **Word Size**, and then use the pop-up numeric keypad to set the word size. Its range is from 4 to 32.

Set the Receiver Word Size

Click or tap the input field of **Receive**, and then use the pop-up numeric keypad to set the receiver word size. Its range is from 4 to 32.

Set the Endian

In **Endian** menu, click or tap to select "**LSB**" or "**MSB**". By default, it is "**MSB**".

Set the Alignment Mode

Click or tap the drop-down button of **Alignment** to select the alignment way for data signal. The available choices include "**I2S**", "**LJ**", and "**RJ**".

Set the Audio Polarity

Click or tap the drop-down button of **WS Low** to select "**Left**" or "**Right**".

Set the Data Polarity

In **Data Polarity** menu, click or tap to select "**Positive**" or "**Negative**".

17.8.3 Display-related Setting

In **Decode** menu, set the following display-related parameters.

Set the Display Format

Click or tap the drop-down button of **Format** to select the display format of the bus data from the drop-down list. The available options include "**Hex**", "**Dec**", "**Bin**", or "**ASCII**".

Set the Label Display

Click or tap the ON/OFF tab for the **Label** menu to enable or disable the label display of the decoding bus. When enabled, the bus label will be displayed at the upper-left side of the bus (when the bus display is enabled). The label shows the current bus type.

17.8.4 Event Table

Open or Close the Event Table

Click or tap the ON/OFF tab for the **Event Table** menu to enable or disable the display of the event table. When enabled, the following event table is displayed, as

shown in the figure below. You can also click or tap the icon  at the upper-right corner of the table to close the event table.

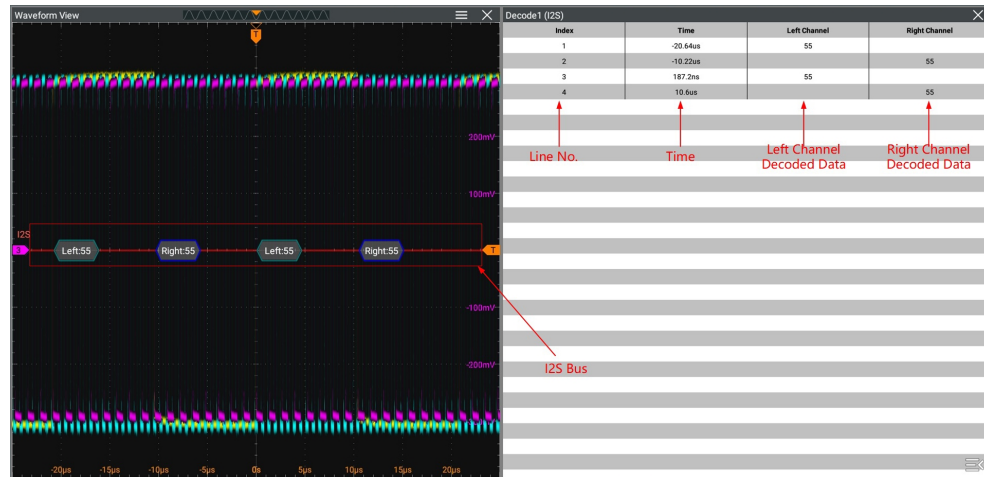

Figure 17.23 I2S Decoding Event Table



TIP

- When you adjust the horizontal time base, the waveform displayed on the screen will also change, and the total number of lines containing the decoding information in the event table will also be changed.
- The displayed decoded data information in the bus is related to the value of the horizontal time base. Reducing the horizontal time base can help you view the detailed information.

Export

When the operating status of the instrument is STOP, you can export the time and corresponding decoding data from the current event table.

Click or tap **Export**, save setting interface is displayed. You can export the data list to the internal memory or the external USB storage device (when detected) in "*.csv" format. For detailed saving operation, refer to descriptions in *Storage*.

17.9 1553B Decoding (Option)

The oscilloscope samples the 1553B signal, and judges each data point to be logic "1" or logic "0" according to the preset threshold level. 1553B decoding is required to specify the data channel source and the threshold.

In the **Decode** menu, click or tap the drop-down button of **Bus Type** to select **1553B**, then configure the parameters for 1553B decoding.

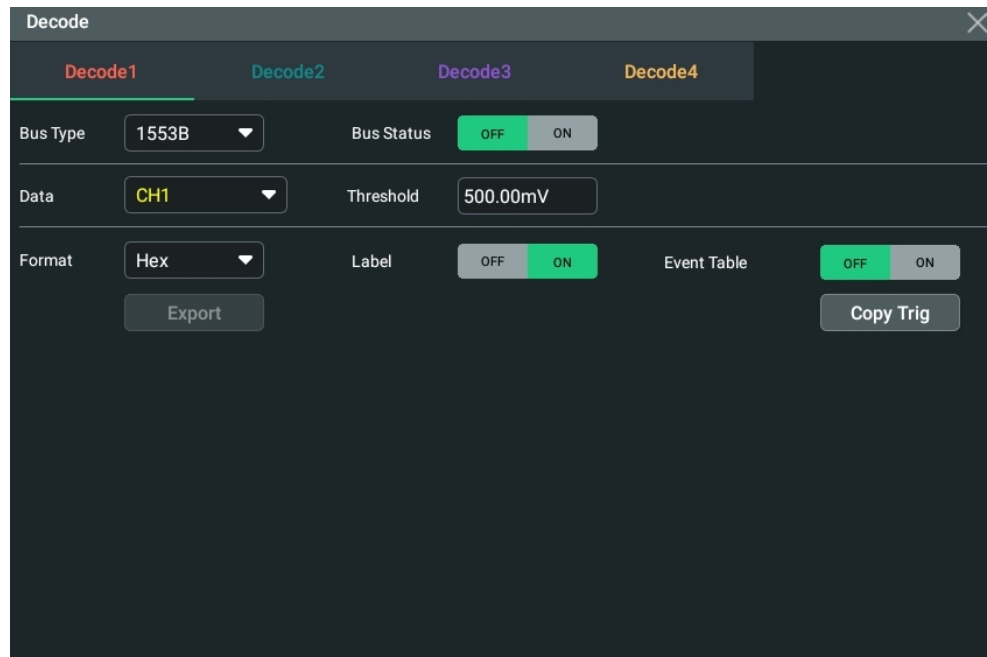

Figure 17.24 1553B Decoding Menu

Bus Status

Click or tap the ON/OFF button for the **Bus Status** menu item to enable/disable the bus decoding.

Quickly Apply Trigger Settings to Decoding

Copy trig indicates applying the trigger settings to the specified decoding setting.

Click or tap **Copy Trig** to apply the trigger settings to the specified decoding setting.

17.9.1 To Set the Data Channel Source and the Threshold

Select the Data Channel

Click or tap the drop-down button of **Data** to select the desired source of the data channel (CH1~CH4) from the drop-down list.

Set the Threshold

Click or tap the input field of **Threshold**, and then use the pop-up numeric keypad to set the threshold of the source channel.

When you modify the threshold of the channel, a dotted line displaying the current threshold level is displayed on the screen. It disappears in about 2 s after you stop modifying the threshold.

17.9.2 Display-related Setting

In **Decode** menu, set the following display-related parameters.

Set the Display Format

Click or tap the drop-down button of **Format** to select the display format of the bus data from the drop-down list. The available options include "Hex", "Dec", "Bin", or "ASCII".

Set the Label Display

Click or tap the ON/OFF tab for the **Label** menu to enable or disable the label display of the decoding bus. When enabled, the bus label will be displayed at the upper-left side of the bus (when the bus display is enabled). The label shows the current bus type.

17.9.3 Event Table

Open or Close the Event Table

Click or tap the ON/OFF tab for the **Event Table** menu to enable or disable the display of the event table. When enabled, the following event table is displayed, as shown in the figure below. You can also click or tap the icon  at the upper-right corner of the table to close the event table.

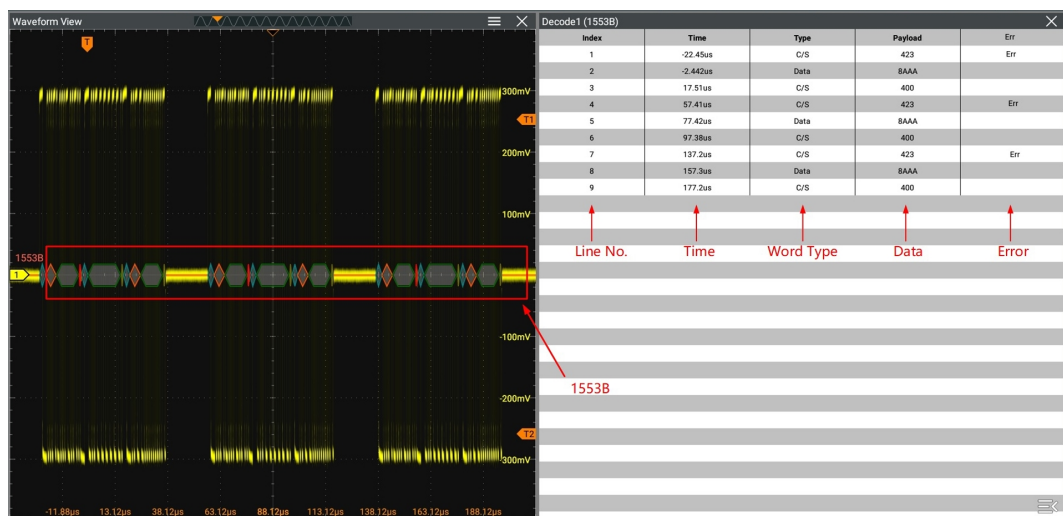

Figure 17.25 1553B Decoding Event Table



TIP

- When you adjust the horizontal time base, the waveform displayed on the screen will also change, and the total number of lines containing the decoding information in the event table will also be changed.
- The displayed decoded data information in the bus is related to the value of the horizontal time base. Reducing the horizontal time base can help you view the detailed information.

Set the Event Table Format

Click or tap the drop-down button of **Format** to select the display format of "Data" in the event table from the drop-down list. The available options include "**Hex**", "**Dec**", "**Bin**", or "**ASCII**".

Export

When the operating status of the instrument is STOP, you can export the time and corresponding decoding data from the current event table.

Click or tap **Export**, save setting interface is displayed. You can export the data list to the internal memory or the external USB storage device (when detected) in "*.csv" format. For detailed saving operation, refer to descriptions in *Storage*.

Interpret the Decoded 1553B Data

- C/S: command/status word. It is expressed in "C/S" form.
- RTA: remote terminal address of the command/status word. It is expressed in "RTA:" form.
- C/S data: the rest data value of the command/status word. Its display format is the same as that of the bus data (Hex, Dec, Bin, or ASCII), displayed as "C/S:".
- Parity bit: displayed as a yellow-green patch; when errors occur, displayed as a red patch.
- Data word data: data of the data word. Its display format is the same as that of the bus data (Hex, Dec, Bin, or ASCII), displayed as "Data:".

17.10 USB2.0 Decoding (Option)

USB2.0 protocol supports data exchange between the host and multiple peripheral devices. A USB system consists of USB interconnect, USB Device, and USB Host. The USB devices are classified as either a hub or a function. Its star topology is shown in the figure below. The Host is Tier 1, and the Hub is the center, with at most 5 hub levels.

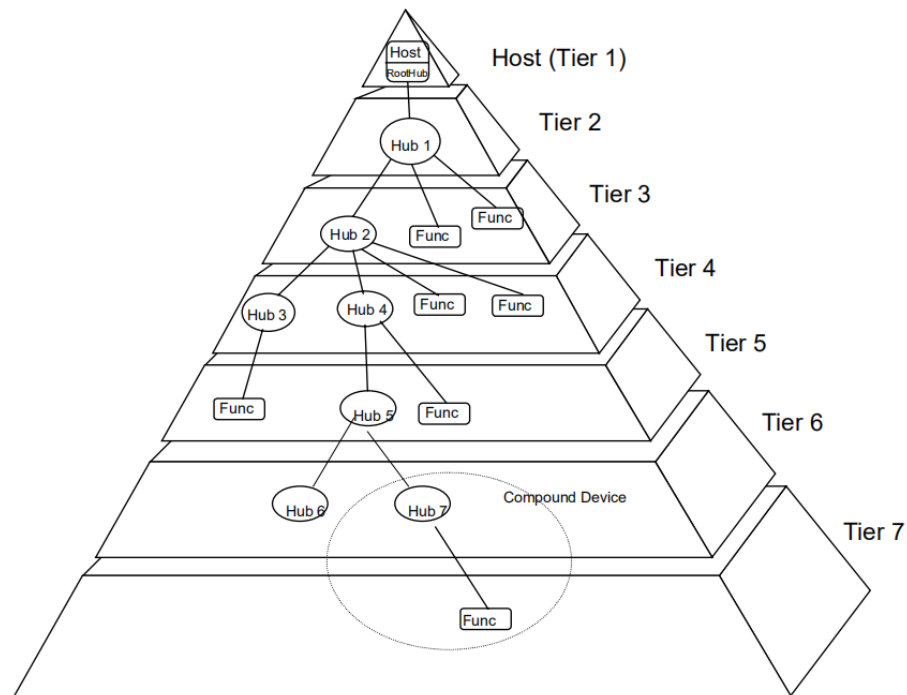

Figure 17.26 USB Topology

In the **Decode** menu, click or tap the drop-down button of **Bus Type** to select **USB2.0**, then configure the parameters for USB2.0 decoding.

Bus Status

Click or tap the ON/OFF button for the **Bus Status** menu item to enable/disable the bus decoding.

Quickly Apply Trigger Settings to Decoding

Copy trig indicates applying the trigger settings to the specified decoding setting.

Click or tap **Copy Trig** to apply the trigger settings to the specified decoding setting.

17.10.1 Signal Configuration

Set the Source and the Threshold

- Click or tap the drop-down button of **Diff** to select the desired differential source (CH1~CH4) from the drop-down list.
- Click or tap the input field of threshold and use the pop-up numeric keypad to set the threshold of the source channel.

Set the Signal

- Select the signal type, which includes low speed, high speed, and full speed.
- Select the polarity of the signal.

17.10.2 Display-related Setting

In **Decode** menu, set the following display-related parameters.

Set the Display Format

Click or tap the drop-down button of **Format** to select the display format of the bus data from the drop-down list. The available options include "Hex", "Dec", "Bin", or "ASCII".

Set the Label Display

Click or tap the ON/OFF tab for the **Label** menu to enable or disable the label display of the decoding bus. When enabled, the bus label will be displayed at the upper-left side of the bus (when the bus display is enabled). The label shows the current bus type.

17.10.3 Event Table

Open or Close the Event Table

Click or tap the ON/OFF tab for the **Event Table** menu to enable or disable the display of the event table. When enabled, the following event table is displayed, as shown in the figure below. You can also click or tap the icon  at the upper-right corner of the table to close the event table.

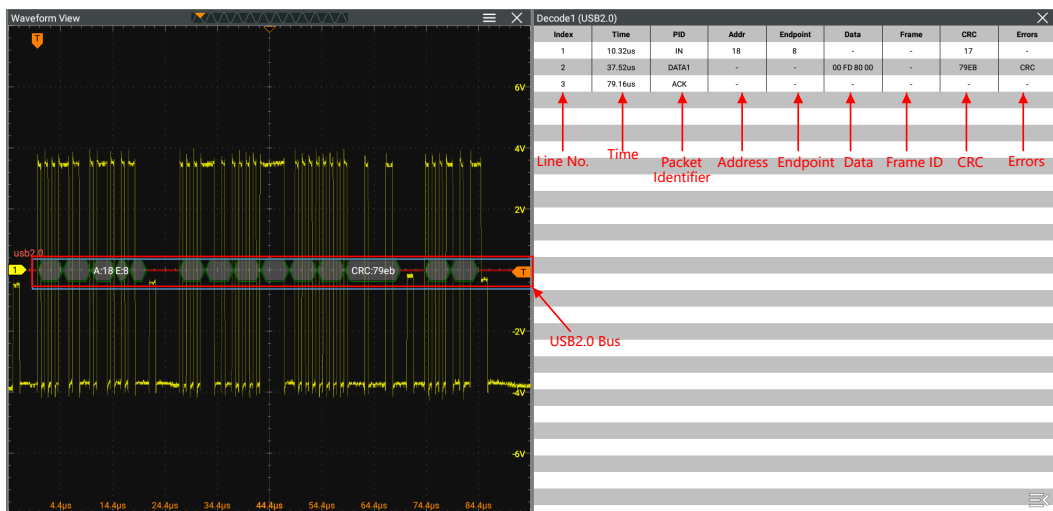

Figure 17.27 USB2.0 Decoding Event Table



TIP

- When you adjust the horizontal time base, the waveform displayed on the screen will also change, and the total number of lines containing the decoding information in the event table will also be changed.

- The displayed decoded data information in the bus is related to the value of the horizontal time base. Reducing the horizontal time base can help you view the detailed information.

Set the Event Table Format

Click or tap the drop-down button of **Format** to select the display format of "Data" in the event table from the drop-down list. The available options include "**Hex**", "**Dec**", "**Bin**", or "**ASCII**".

Export

When the operating status of the instrument is STOP, you can export the time and corresponding decoding data from the current event table.

Click or tap **Export**, save setting interface is displayed. You can export the data list to the internal memory or the external USB storage device (when detected) in "*.csv" format. For detailed saving operation, refer to descriptions in *Storage*.

18 Serial Bus Compliance Analysis (Option)

DS80000 series supports serial bus compliance analysis.

If you have purchased the Compliance Test option, activate it according the descriptions in *To View the Option Information and the Option Installation*.

18.1 USB2.0 Compliance Analysis (Option)

This series oscilloscope supports USB2.0 signal quality compliance analysis. It is available to use when you have purchased and activated the USBC option.

To enter the "USB2.0 Compliance Analysis" interface, perform the following operations.

- Click or tap  > **USB** to enter the "USB2.0 Compliance Analysis" interface.
- Click or tap  > **Windows** (you can also click or tap the **Windows** icon on the quick operation toolbar at the upper-right corner of the screen) to enter the "Add Window" interface.

Click or tap to select **USB Analysis** under the "Diagram" menu. Its preview and parameter setting item is displayed at the upper part of the "Add Window" interface. Click or tap **Add**, then the "USB2.0 Test Results" window is displayed.

Click or tap  at the upper-right corner of the window to enter the "USB2.0 Compliance Analysis" menu.

You can select the DUT, configure the acquired signal information, save and analyze the test results.



TIP

This function is required to work with the fixture. For the specific fixture type, software, and test connection diagram, please refer to *USB2.0 Signal Compliance Analysis Test Fixture*.

18.1.1 DUT

In the **DUT** tab, select the desired type under "DUT", "Signal Type", and "Test Point".

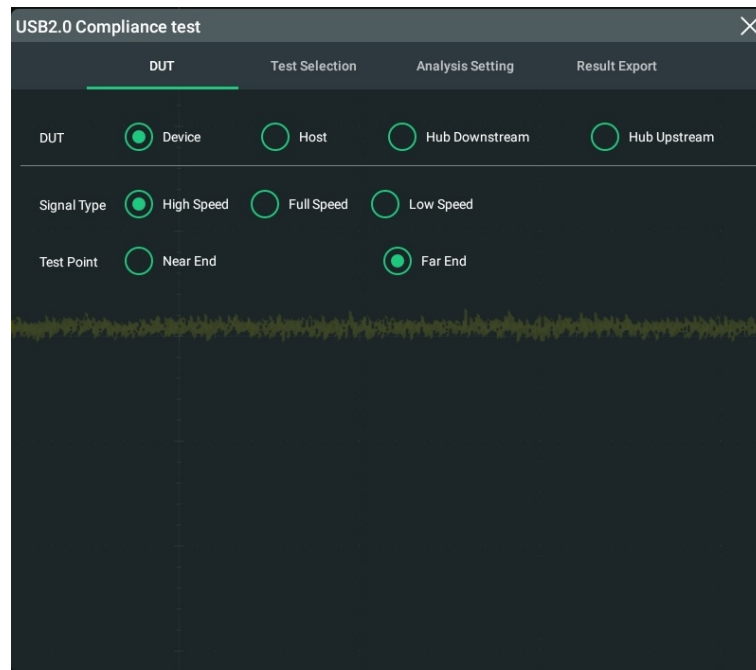

DUT

Selects "Device", "Host", "Hub Downstream", or "Hub Upstream".

Signal Type

Selects "High Speed", "Full Speed", or "Low Speed".

Test Point

When the signal type is "High Speed", you can select "Near End" or "Far End" as the test point according to the test scenario. Whether you select "Near End" or "Far End", it determines the test port of the DUT, as shown in the figure below.

- "Near End" should be selected in the following conditions: no USB cable is available before the the DUT and the host; the test point is located in TP3; Template1 is selected for the eye template according to USB2.0 protocol.
- "Far End" should be selected in the following conditions: A USB cable is available before the the DUT and the host; the test point is located in TP2; Template2 is selected for the eye template according to USB2.0 protocol.

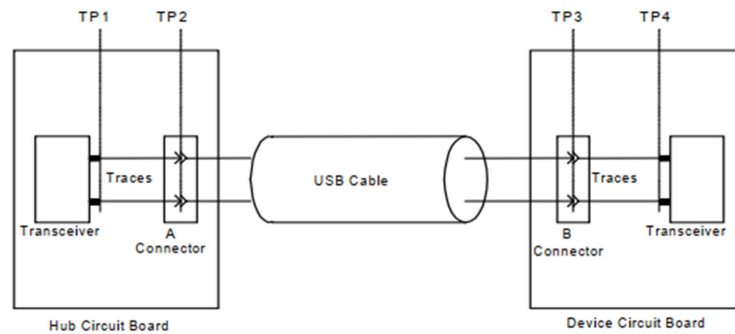
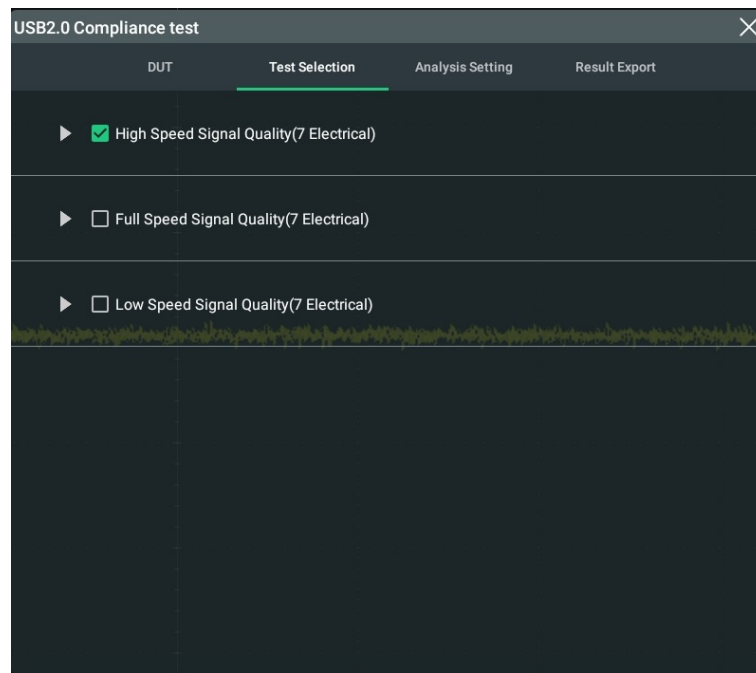

Figure 18.1 USB2.0 Test Model

18.1.2 Test Selection

Click or tap the **Test Selection** tab to select the desired item. When you select a different signal type in the **DUT** tab, the default test selection item is different.



High Speed Signal Quality(7 Electrical)

When you select "High Speed" for the "Signal Type" in the "DUT" tab, "High Speed Signal Quality(7 Electrical)" is selected, by default, under the Test Selection tab. Click or tap the "Triangle" icon to unfold the test items. The following table lists the measuring items, Maximum, Minimum, and Standard Number of the high speed signal.

Table 18.1 High-speed Signal Quality Compliance Test Item

Measuring Item	Minimum	Maximum	Standard Number
SYNC Width	32 bits	32 bits	EL_2
EOP Width	39.5 bits (7.5 bits) ^[1]	40.5 bits (8.5 bits) ^[1]	EL_2
Signal Rate	479.76 Mb/s	480.24 Mb/s	EL_2
Rise Time	500 ps	N/A	EI_2
Fall Time	500 ps	N/A	EL_2
Edge Monotonicity	0	50 mV	EL_7
Rise Edge Rate	N/A	1600 V/us	EI_2
Fall Edge Rate	N/A	1600 V/us	EI_2
Paired JK Jitter	-100 ps	100 ps	EI_4
Paired KJ Jitter	-100 ps	100 ps	EI_4
Consecutive Jitter	-100 ps	100 ps	EI_4
Signal Eye Violation Points	0	0	EI_4

NOTE

[1]: data enclosed by brackets in the EOP Width field are non-start frame data.

**Full Speed Signal Quality(7 Electrical)**

When you select "Full Speed" for the "Signal Type" in the "DUT" tab, "Full Speed Signal Quality(7 Electrical)" is selected, by default, under the Test Selection tab. Click or tap the "Triangle" icon to unfold the test items. The following table lists the measuring items, Maximum, Minimum, and Standard Number of the full speed signal.

Table 18.2 Full-speed Signal Quality Compliance Test Item

Measuring Item	Minimum	Maximum	Standard Number
SYNC Width	8 bits	8 bits	EL_2

Measuring Item	Minimum	Maximum	Standard Number
EOP Width	160 ns	175 ns	EL_2
Signal Rate	11.97 Mb/s	12.03 Mb/s	EL_2
Rise Time	4 ns	20 ns	EL_2
Fall Time	4 ns	20 ns	EL_2
Cross Volt	1.3 V	2.0 V	EL_2
Rise Edge Rate	100 V/us	720 V/us	EL_2
Fall Edge Rate	100 V/us	720 V/us	EL_2
Paired JK Jitter	-1 ns	1 ns	EL_4
Paired KJ Jitter	-1 ns	1 ns	EL_4
Consecutive Jitter	-2 ns	2 ns	EL_4
Signal Eye Violation Points	0	0	EL_4

Low Speed Signal Quality(7 Electrical)

When you select "Low Speed" for the "Signal Type" in the "DUT" tab, "Low Speed Signal Quality(7 Electrical)" is selected, by default, under the Test Selection tab. Click or tap the "Triangle" icon to unfold the test items. The following table lists the measuring items, Maximum, Minimum, and Standard Number of the low speed signal.

Table 18.3 Low-speed Signal Quality Compliance Test Item

Measuring Item	Minimum	Maximum	Standard Number
SYNC Width	8 bits	8 bits	EL_2
EOP Width	1.25 us	1.5 us	EL_2
Signal Rate	1.4775 Mb/s	1.5225 Mb/s	EL_2
Rise Time	75 ns	300 ns	EL_2
Fall Time	75 ns	300 ns	EL_2
Cross Volt	1.3 V	2.0 V	EL_2

Measuring Item	Minimum	Maximum	Standard Number
Rise Edge Rate	6.67 V/us	38.4 V/us	EL_2
Fall Edge Rate	6.67 V/us	38.4 V/us	EL_2
Paired JK Jitter	-10 ns	10 ns	EL_4
Paired KJ Jitter	-10 ns	10 ns	EL_4
Consecutive Jitter	-25 ns	25 ns	EL_4
Signal Eye Violation Points	0	0	EL_4

18.1.3 Analysis Setting

Click or tap the **Analysis Setting** tab. In the **Analysis Setting** interface, select the connection mode, source, and view the configuration information.

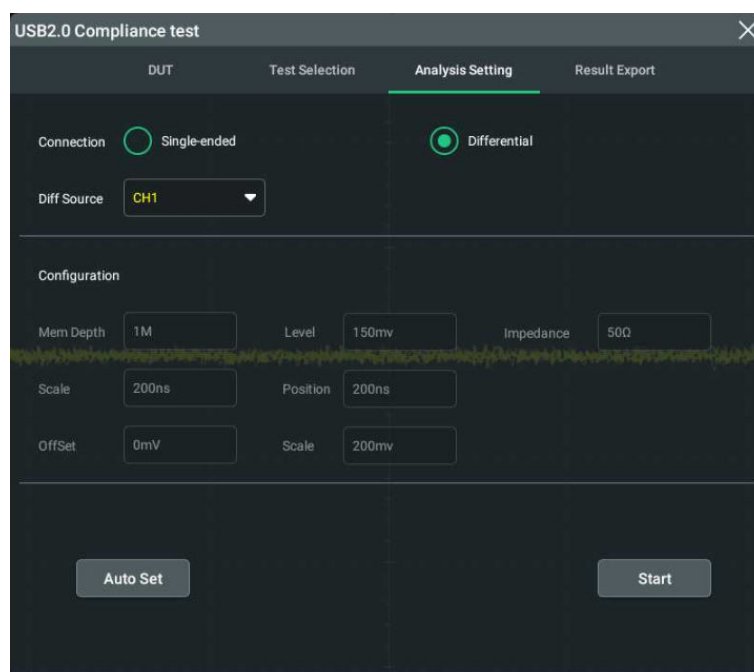

Connection

- When performing the "high speed" signal quality compliance test, you need to select "Single-ended" or "Differential" for the "Connection" item.
- When performing the "low speed" or "full speed" signal quality compliance test, select "Single-ended" for the "Connection" item.

Source

- When "Single-ended" is selected,
 - Click or tap the drop-down button of "Source Dp" to select the desired channel (CH1~CH4).
 - Click or tap the drop-down button of "Source Ds" to select the desired channel (CH1~CH4).
- When "Differential" is selected,
 - Click or tap the drop-down button of "Diff Source" to select the desired channel (CH1~CH4).

Signal Configuration

The configuration information is different for different types of the signal types, as shown in the following table.

Table 18.4 Signal Configuration

Configuration	High Speed Signal	Full Speed Signal	Low Speed Signal
Memory Depth	1 M	1 M	1 M
Trigger Level	150 mV	1 V	1 V
Impedance	50 Ω	1 M Ω	1 M Ω
Scale	200 ns/div	1 us/div	10 us/div
Offset	200 ns	3 us	30 us
Position	0 mV	0 mV	0 mV
Scale	200 mV/div	1000 mV/div	1000 mV/div

Auto Set

Click or tap **Auto Set** to configure the signal information automatically.

Launch the Test

Click or tap **Start** to start the USB2.0 signal quality compliance analysis test.

18.1.4 Result Export

In the **Result Export** tab, you can view or save the USB2.0 signal quality compliance analysis test results.

Format

Sets the format of the saved file. It can be saved in "*.html" or ".pdf" format.

Report

Click or tap ON or OFF under "Report" to enable or disable the display of the analysis report. When enabled, the test report results are displayed at the right section of the screen.



Figure 18.2 USB2.0 Signal Quality Compliance Analysis Test Result

Set the File Saving Parameters

- **Set the filename**

Click or tap the input field of **File Name** to input the file name to be saved with the pop-up virtual keypad.

- **Set the file path**

Click or tap the input field of **File Path**, then the disk management interface is displayed. For detailed operations, refer to descriptions in *Disk Management*.

- **Overlay**

Click or tap the ON/OFF button for the **Overlay** menu to enable or disable the overwriting function. When enabled, the existing file in the specified file path will be overwritten by the newly saved file that has the same filename as the existing one.

- **Set the device ID**

Click or tap the input field of **Device ID** to input the device ID to be saved with the pop-up virtual keypad.

- **Set the description**

Click or tap the input field of **Description** to input the device description to be saved with the pop-up virtual keypad.



- **Set the device port ID**

Click or tap the input field of **Device Port ID** to input the device port ID to be saved with the pop-up virtual keypad.

18.2 LAN Compliance Analysis (Option)

This series oscilloscope supports Ethernet signal quality compliance analysis. It is available to use when you have purchased and activated the ENETC option.

To enter the "LAN Compliance Analysis" interface, perform the following operations.

- Click or tap  > **LAN** to enter the "LAN Compliance Analysis" interface.
- Click or tap  > **Windows** (you can also click or tap the **Windows** icon on the quick operation toolbar at the upper-right corner of the screen) to enter the "Add Window" interface.

Click or tap to select "LAN Analysis" under the **Diagram** menu. Its preview and parameter setting item is displayed at the upper part of the "Add Window" interface. Click or tap the drop-down button of **Type** to select "100Base-T" or

"1000Base-T", then click or tap **Add**. The "100Base-T Test Results" or "1000Base-T Test Results" window is displayed. Click or tap  at the upper-right corner of the window to enter the "LAN Compliance Analysis" menu.



TIP

This function is required to work with the LAN signal compliance analysis fixture. For the specific fixture type, software, and test connection diagram, please refer to *Ethernet Compliance Analysis Test Fixture (TF-ENET-STP User Guide)*.

18.2.1 To Select the Signal Type

In the "LAN Compliance Analysis" interface, click or tap the drop-down button of **Signal Type** to select the desired signal type.

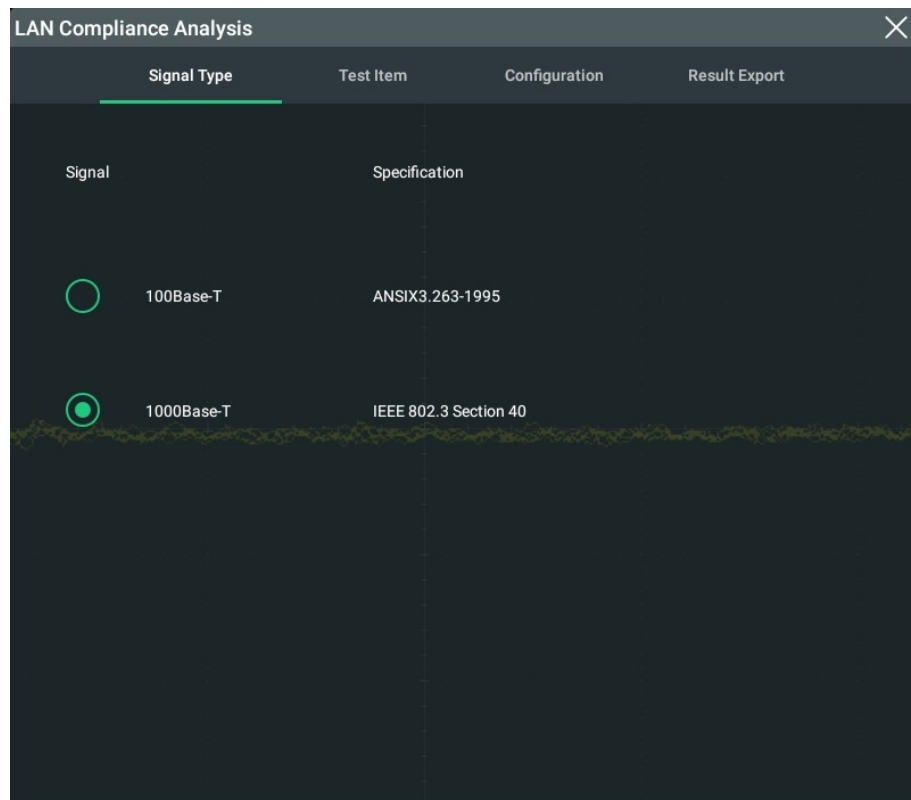





Figure 18.3 Signal Type

Click or tap the specified signal type to perform the LAN compliance analysis test.

- 100Base-T: indicates the 100Base-T Ethernet signal which complies with the protocol ANSIX3.263-1995.
- 1000Base-T: indicates the 1000Base-T Ethernet signal which complies with the protocol IEEE 802.3 Section40.

18.2.2 To Select the Test Item

Click or tap **Test Item** in the "LAN Compliance Analysis" interface to enter the test item menu, as shown in *Figure 18.4* and *Figure 18.5*. The test items for the 100Base-T and 1000Base-T signals are different.

Click or tap the icon  to unfold all the sub-items. Click or tap to select the checkbox . When it turns out be , the specified test item is selected.

18.2.2.1 100Base-T Signal Test Items

Select 100Base-T as the signal type. The Test Item menu is shown in the following figure.

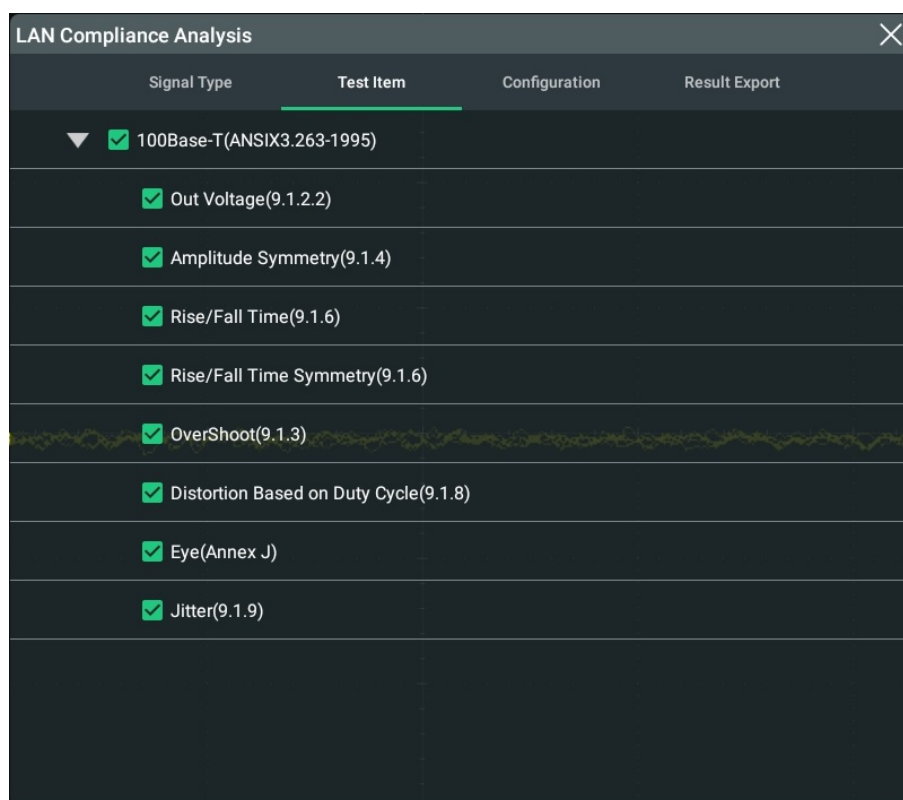

Figure 18.4 100Base-T Signal Test Items

The pass conditions for the test items are shown in the following table.

Table 18.5 Pass Conditions for the Test Items of the 100Base-T Signal Type

Test Item	Description	Pass Conditions	
		Min.	Max.
Out Voltage	+Vout	950 mV	1050 mV

Test Item	Description	Pass Conditions	
		Min.	Max.
	-Vout	-1050 mV	-950 mV
Amplitude Symmetry	Signal Amplitude Symmetry	0.98	1.02
Rise/Fall Time	Rise Time Test for Positive Pulse (+Ve)	3 ns	5 ns
	Rise Time Test for Negative Pulse (-Ve)		
	Fall Time Test for Positive Pulse (+Ve)		
	Fall Time Test for Negative Pulse (-Ve)		
Rise/Fall Time Symmetry	Rise/Fall Time Symmetry Test for Positive Pulse (+Ve)	0 ps	500 ps
	Rise/ Fall Time Symmetry Test for Negative Pulse (-Ve)		
OverShoot	Overshoot Test for Positive Pulse (+Ve)	0%	5%
	Overshoot Test for Negative Pulse (-Ve)		
Distortion Based on Duty Cycle	Duty Distortion Test	0 ps	500 ps
Eye	Eye Diagram	N/A	N/A
Jitter	Jitter Test with Positive Polarity (+Ve)	0 ns	1.4 ns
	Jitter Test with Negative Polarity (-Ve)		

18.2.2.2 1000Base-T Signal Test Items

Select 1000Base-T as the signal type. The Test Item menu is shown in the following figure.

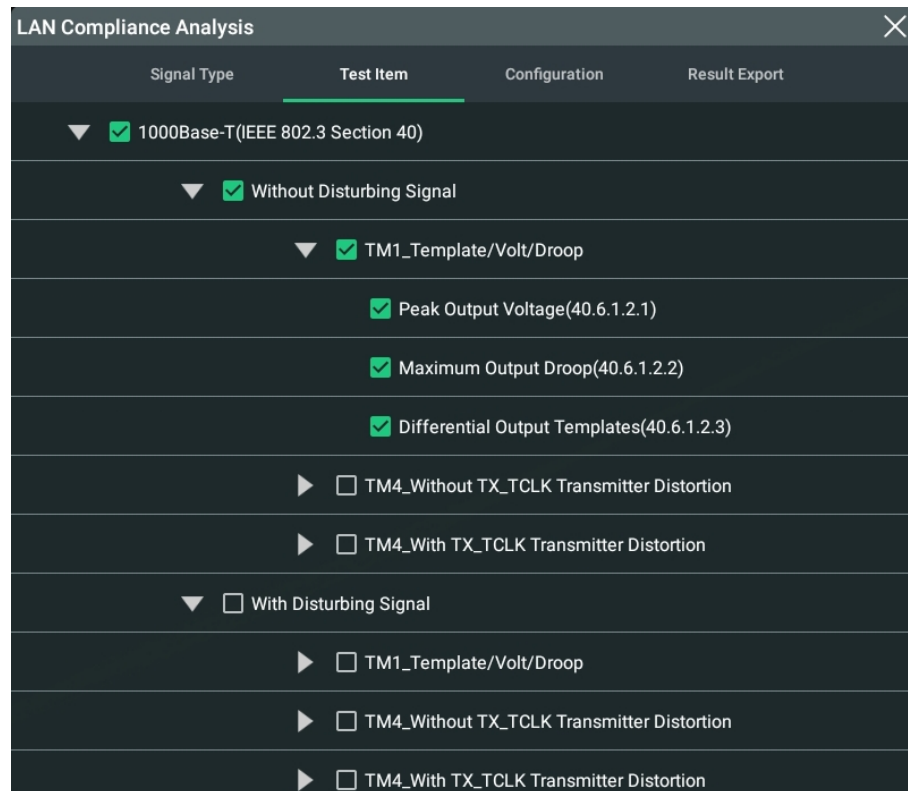

Figure 18.5 1000Base-T Signal Test Items

According to the rules of IEEE 802.3 standards for the 1000BASE-T physical layer compliance test, the DUT is required to perform a series of compliance testing in the four test modes. In the generated analysis report, you can query the pass/fail condition and test results of each test project. To obtain the report, refer to [Result Report](#).

Test Mode 1

Includes Template, Volt, and Droop.

- Peak Output Voltage (40.6.1.2.1)
- Maximum Output Droop(40.6.1.2.2)
- Differential Output Templates (40.6.1.2.3)

Two test scenarios: With Disturbing Signal and Without Disturbing Signal

- Without Disturbing Signal > TM1_Template/Volt/Droop:
Test Mode 1 under the scenario without the disturbing signal
- With Disturbing Signal > TM1_Template/Volt/Droop:
Test Mode 1 under the scenario with the disturbing signal

Test Mode 1 needs to test A, B, C, D, F, G, H, and J test points of the waveforms.

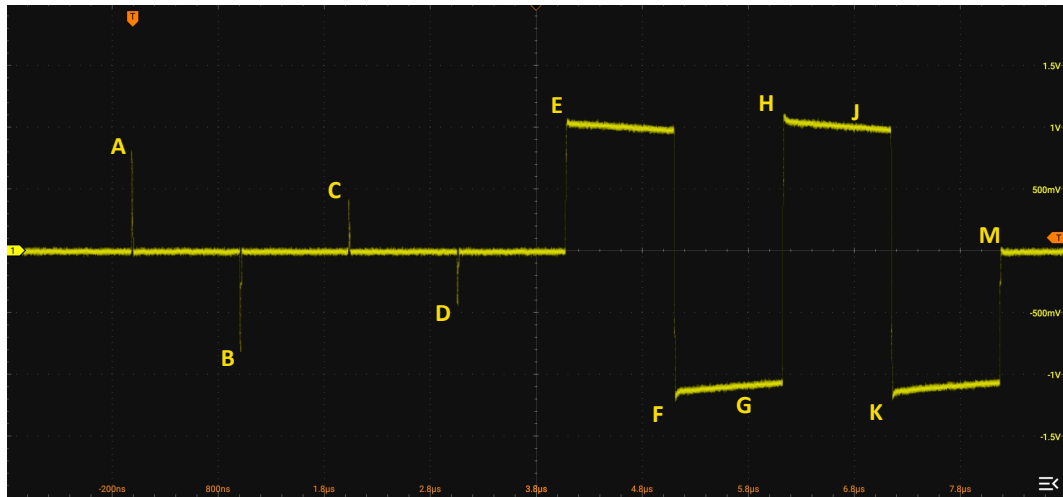

Figure 18.6 Typical Waveform of Test Mode 1 Signal

The pass conditions for the test item are shown in the following table.

Table 18.6 Pass Conditions for Test Mode 1

Test Item	Test Contents	Pass Conditions	
		Min.	Max.
Peak Output Voltage	Peak Differential Output Voltage A	0.67 V	0.82 V
	Peak Differential Output Voltage B		
	% Diff A & B	0%	1%
	% Diff C & (A and B)	0%	2%
	% Diff D & (A and B)		
Differential Output Templates	Test A, B, C, D, F, and H	-	-
Maximum Output Droop	Max. Output Droop (Point F and Point G)	73.1%	-
	Max. Output Droop (Point H and Point J)		

Test Mode 2

Includes the Jitter Master Mode test. Four test scenarios are available based on whether having the clock signal or being filtered.

- TM2/TM3 Without TX_TCLK > Unfiltered Jitter Master Mode (40.6.1.2.5):
Jitter Master Mode test without the clock signal and unfiltered
- TM2/TM3 Without TX_TCLK > Filtered Jitter Master Mode (40.6.1.2.2):
Jitter Master Mode test without the clock signal and filtered
- TM2/TM3 With TX_TCLK > Unfiltered Jitter Master Mode (40.6.1.2.5):
Jitter Master Mode test with the clock signal and unfiltered
- TM2/TM3 With TX_TCLK > Filtered Jitter Master Mode (40.6.1.2.2):
Jitter Master Mode test with the clock signal and filtered

Table 18.7 Pass Conditions for Test Mode 2

Test Item	Clock Signal (TX_TCLK)	Filtered/Unfiltered	Pass Conditions	
			Min.	Max.
Jitter Master Mode	TM2/TM3 Without TX_TCLK	Unfiltered	0 ns	1.4 ns
	TM2/TM3 Without TX_TCLK	Filtered	0 ns	0.3 ns
	TM2/TM3 With TX_TCLK	Unfiltered	0 ns	1.4 ns
	TM2/TM3 With TX_TCLK	Filtered	0 ns	0.3 ns

Test Mode 3

Includes the Jitter Slave Mode test. Four test scenarios are available based on whether having the clock signal or being filtered.

- TM2/TM3 Without TX_TCLK > Unfiltered Jitter Slave Mode (40.6.1.2.5):
Jitter Slave Mode test without the clock signal and unfiltered
- TM2/TM3 Without TX_TCLK > Filtered Jitter Slave Mode (40.6.1.2.2):
Jitter Slave Mode test without the clock signal and filtered
- TM2/TM3 With TX_TCLK > Unfiltered Jitter Slave Mode (40.6.1.2.5):
Jitter Slave Mode test with the clock signal and unfiltered
- TM2/TM3 With TX_TCLK > Filtered Jitter Slave Mode (40.6.1.2.2):
Jitter Slave Mode test with the clock signal and filtered

Table 18.8 Pass Conditions for Test Mode 3

Test Item	Clock Signal (TX_TCLK)	Filtered/ Unfiltered	Pass Conditions	
			Min.	Max.
Jitter Slave Mode	TM2/TM3 Without TX_TCLK	Unfiltered	0 ns	1.4 ns
	TM2/TM3 Without TX_TCLK	Filtered	0 ns	0.4 ns
	TM2/TM3 With TX_TCLK	Unfiltered	0 ns	1.4 ns
	TM2/TM3 With TX_TCLK	Filtered	0 ns	0.4 ns

Test Mode 4

Includes the transmitter distortion and common-mode output voltage tests.

- Transmitter Distortion (40.6.1.2.4):
- TM4_Common > TM4_Common-mode Output Voltage (40.8.3.3): common-mode output voltage test.

Four test scenarios are available for transmitter distortion based on whether having the clock signal and the disturbing signal.

- Without Disturbing Signal > TM4_Without TX_TCLK Transmitter Distortion:
Transmitter Distortion test without disturbing signal and without the clock signal
- Without Disturbing Signal > TM4_With TX_TCLK Transmitter Distortion:
Transmitter Distortion test without disturbing signal and with the clock signal
- With Disturbing Signal > TM4_Without TX_TCLK Transmitter Distortion:
Transmitter Distortion test with disturbing signal and without the clock signal
- With Disturbing Signal > TM4_With TX_TCLK Transmitter Distortion:
Transmitter Distortion test with disturbing signal and with the clock signal

Table 18.9 Pass Conditions for Test Mode 4

Test Item	Pass Conditions	
	Min.	Max.
Transmitter Distortion	0 mV	10 mV
TM4_Common-mode Output Voltage	0 mV	50 mV

18.2.3 Configuration Menu

After selecting a test item, click or tap the **Configuration** tab to enter the Configuration menu, as shown in the following figure.

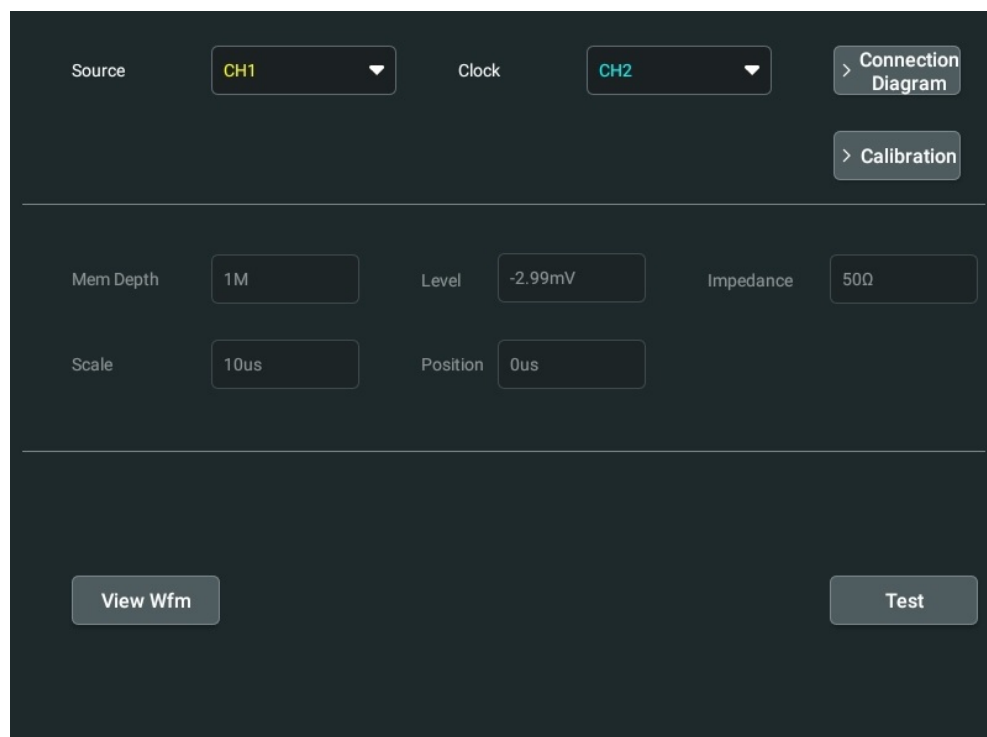

Figure 18.7 Configuration Menu

18.2.3.1 To Configure the Source

As the test signals required for different test items in the LAN compliance analysis test are different, you need to configure different sources for different test items. For DS80000, the available source channels are CH1-CH4.



TIP

The source configuration shall be consistent with the source specified in the test connection diagram.

Configure the Source

For the following test items, only one source channel is required to be configured to obtain the data signal under test.

- All the test items of the 100Base-T signal.
- The following test items of the 1000Base-T signal. They include
 - Without Disturbing Signal > TM1_Template/Volt/Droop
 - With Disturbing Signal > TM1_Template/Volt/Droop
 - Without Disturbing Signal > TM4_Without TX_TCLK Transmitter Distortion
 - With Disturbing Signal > TM4_Without TX_TCLK > Transmitter Distortion
 - TM4_Common > TM4_Common-mode Output Voltage

Configure the Source and the Clock Source

For the following test items, you need to configure one source channel to obtain the data signal and one clock source to obtain the clock signal. The channels selected for the source channel and the clock channel should be different.

- Without Disturbing Signal > TM4_With TX_TCLK Transmitter Distortion
- With Disturbing Signal > TM4_With TX_TCLK Transmitter Distortion

Configure the Data Source

In the jitter test without the clock signal, only one source channel is required to be configured to obtain the data source in the master or slave mode.

- TM2/TM3 Without TX_TCLK > Unfiltered Jitter Master Mode
- TM2/TM3 Without TX_TCLK > Unfiltered Jitter Slave Mode
- TM2/TM3 Without TX_TCLK > Filtered Jitter Master Mode
- TM2/TM3 Without TX_TCLK > Filtered Jitter Slave Mode

Configure the Master Clock Source

In the unfiltered jitter master test with the clock signal, only one master clock source is required to be configured to obtain the clock signal in the jitter master mode.

Test item: TM2/TM3 With TX_TCLK > Unfiltered Jitter Master Mode

Configure the Master Clock Source and the Slave Clock Source

In the unfiltered jitter slave test with the clock signal, configure one master clock source and one slave clock source to obtain the clock signal in the jitter master

mode and jitter slave mode respectively. The channels selected for master clock source and slave clock source are different.

Test item: TM2/TM3 With TX_TCLK > Unfiltered Jitter Slave Mode

Configure the Master Clock Source and the Data Source

In the filtered jitter master test with the clock signal, you need to switch the device under test. The test signals obtained before and after switching the device are different.

- Before switching the device, obtain the clock signal of the master device working in normal mode.
- After switching to another device, obtain the clock signal and data signal of the device working in master mode. Configure one master clock source and one data source. The channels for the two sources are different.

Test item: TM2/TM3 With TX_TCLK > Filtered Jitter Master Mode

Configure the Data/Master Clock Source and the Slave Clock Source

In the filtered jitter slave test with the clock signal, you need to switch the device under test. The test signals obtained before and after switching the device are different.

- Before switching the device, obtain the clock signal of the master device and the slave device working in normal mode. One master clock source and one slave clock source are required to be configured. The channels for the two sources are different.
- After switching to another device, obtain the clock signal and data signal of the device working in slave mode. Configure one data source and one slave clock source respectively. The channels selected for data source and slave clock source are different.

Test item: TM2/TM3 With TX_TCLK > Filtered Jitter Slave Mode

18.2.3.2 Fixture Calibration

In the Configuration menu, click or tap **Calibration** to enter the fixture calibration menu, as shown in the figure below.

The screenshot shows a 'DUT Calibration' window with a close button (X) in the top right corner. It is divided into two main sections: 'Disturbing Signal' and 'DUT Calibration'.

Disturbing Signal Section:

	Expected Value	Measured Value	Action
Frequency	31.25MHz	31.25MHZ	Measure
Amplitude	1.4V	1.40V	Default

DUT Calibration Section:

	Expected Value	Measured Value	Action
TC2 Amplitude	750mV	750.00mV	Measure
TC5 Amplitude	500mV	500.00mV	Measure
Amplitude Attenuati	1.5X	1.50X	Default

At the bottom of the window, there are three buttons: '< Back', 'Apply', and '> Connection Diagram'.

Figure 18.8 Fixture Calibration

For the test items with the disturbing signal, perform calibration for the disturbing signal and the fixture.

Connection Diagram

In the Calibration menu, click or tap **Connection Diagram** to enter the Connection Diagram menu. The Connection Diagram interface shows the calibration connection diagram for the disturbing signal, TC2, and TC5. Below the diagram are the calibration procedures. You can drag up and down the page to view the complete information.

Click or tap **Back** to return to the Fixture Calibration menu.

Calibration for Disturbing Signals

The Expected Value shows the ideal frequency and amplitude value of a disturbing signal.

Connect the device for calibrating the disturbing signal according to the connection diagram, then perform the test according to the test procedures. Click or tap **Test** to start testing for the actual disturbing signal. After completing the test, the measured

frequency and amplitude values of the disturbing signal are displayed in the "Measured Value" field. Compare the measured value and the expected value. If they are not close to each other, modify the amplitude and frequency of the disturbing signal to test again until they are approximately equivalent.

If the disturbing signal does not need to be calibrated, click or tap **Default**, and the expected value will be used as the measured value of the disturbing signal.

Fixture Calibration

The Expected Value field shows the ideal measured value of the TC2 amplitude, TC5 amplitude, and amplitude attenuation.

Connect the device for calibrating TC2 and TC5 according to the connection diagram, then perform the test according to the test procedures. Click or tap **Test** to start testing. After completing the test, the measured TC2 amplitude value, TC5 amplitude value, and amplitude attenuation value are displayed in the "Measured Value" field.

If the fixture does not need to be calibrated, click or tap **Default**, and the expected value will be used as the measured value of TC2 and TC5.

Apply

After completing the test for the disturbing signal, TC2, and TC5, click or tap **Apply** to complete the calibration configuration.

Back

Click or tap **Back** to return to the Configuration menu.

18.2.3.3 To Launch the Test

In the "Configuration" tab, you can preview the current test waveform and view the current waveform configuration parameters. You can also launch the test for the specified test item.

Preview the Waveform

Click or tap **View Wfm** to preview the waveform for the specified test item in the waveform view to ensure that the waveform is properly output.

Launch the Test

Click or tap **Test** to start the LAN compliance analysis test.

Configure Parameters

After the specified signal type and test item are selected, the waveform parameters of the oscilloscope such as level, scale, and impedance can be seen in the Configuration menu, as shown in *Figure 18.7*. The configuration parameters for different test items are different.

**TIP**

These parameters displayed in the "Configuration" menu are the parameters for the previewed test waveform. After starting the test, the parameters will be automatically adjusted.

18.2.4 Result Report

You can view the LAN compliance analysis test report and save it to the local path.

In the "LAN Compliance Analysis" interface, click or tap **Result Export** to enter the result export menu.

Format

The report can be saved in "*.html" or "*.pdf" format.

Report

Click or tap ON or OFF under "Report" to enable or disable the display of the analysis report. When enabled, the test report as shown in the figure below is displayed at the right section of the screen.

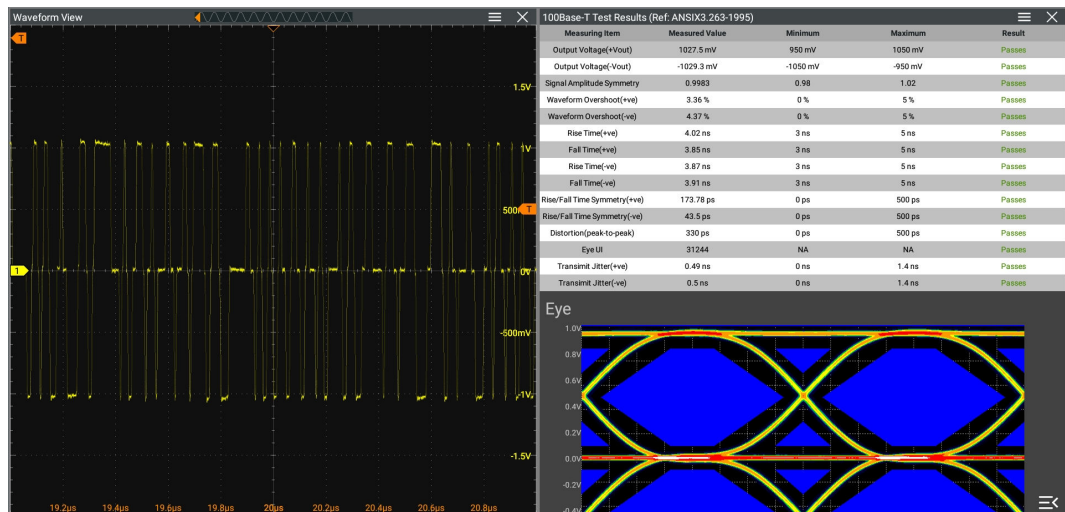

Figure 18.9 LAN Compliance Analysis Test Report

Data Clear

Click or tap **Data Clear** to clear all the saved report data.

Set the File Saving Parameters

- **Set the filename**

Click or tap the input field of **File Name** to input the file name to be saved with the pop-up virtual keypad.

- **Set the file path**

Click or tap the input field of **File Path**, then the disk management interface is displayed. For detailed operations, refer to descriptions in *Disk Management*.

- **Overlay**

Click or tap the ON/OFF button for the **Overlay** menu to enable or disable the overwriting function. When enabled, the existing file in the specified file path will be overwritten by the newly saved file that has the same filename as the existing one.

- **Set the device ID**

Click or tap the input field of **Device ID** to input the device ID to be saved with the pop-up virtual keypad.

- **Set the description**

Click or tap the input field of **Description** to input the device description to be saved with the pop-up virtual keypad.

- **Set the device port ID**

Click or tap the input field of **Device Port ID** to input the device port ID to be saved with the pop-up virtual keypad.

- **Set the network cable**

Click or tap the input field of **Network Cable** to input the network cable to be saved with the pop-up virtual keypad.

19 Multi-pane Windowing

DS80000 supports multi-pane windowing. Users can add multiple windows and result display windows for display and view.

Click or tap  > **Windows** to enter the "Add Window" interface. You can also click or tap the "Windows" icon in the quick operation bar at the top of the screen to enter the "Add Window" interface.

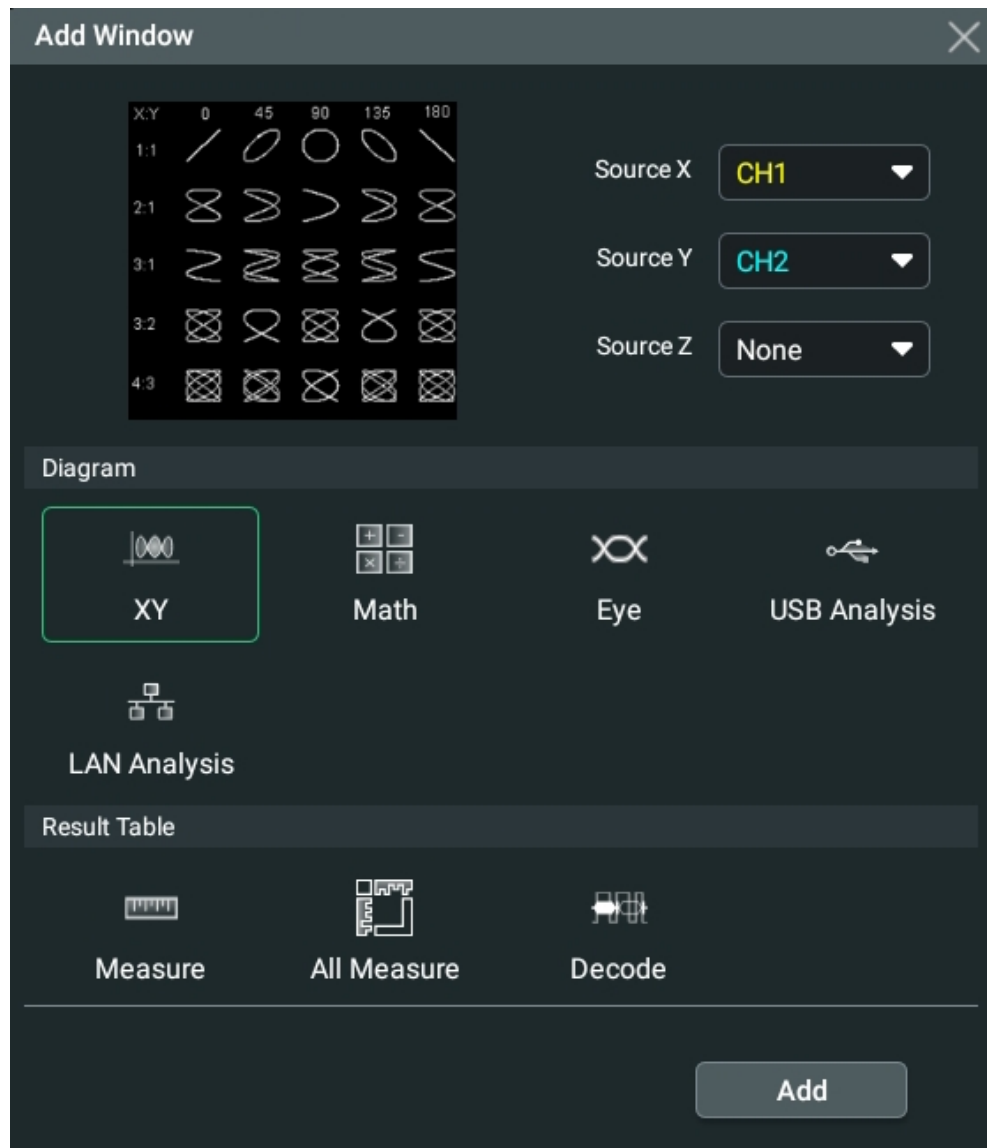

Figure 19.1 "Add Window" Menu

Add Diagram Windows

1. First, click or tap "XY", "Math", "Eye", "USB Analysis", or "LAN Analysis" under the **Diagram** menu. When a diagram is selected, its preview and parameter setting items can be displayed at the upper part of the "Add Window" interface.

2. You can set the corresponding parameters according to your needs. For detailed setting methods, refer to descriptions of relevant chapters.
3. Click or tap **Add**, then the selected diagram is displayed on the screen.

Add Result Table Window

Click or tap "**Measure**", "**All Measure**", or "**Decode**" under the **Result Table** menu, then click or tap **Add**. The corresponding measurement results will be displayed on the screen.

20 Waveform Recording and Playing

Waveform recording/playing function enables you to record and play the waveforms of the analog input channels (CH1~CH4) to better analyze the waveforms.

To enter the waveform recording menu, perform any of the following operations:

- Click or tap  > **Record** to enter the waveform recording setting menu.
- Tap the **Record** icon on the secondary screen at the right side of the front panel to enter the waveform recording setting menu.
- Click or tap the **Record** icon on the quick operation toolbar at the top of the screen to enter the waveform recording setting menu.

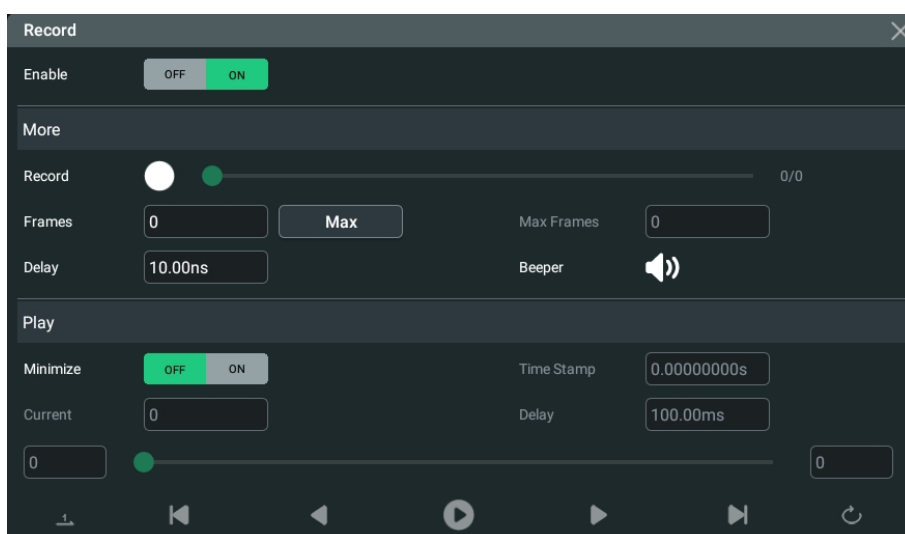





Figure 20.1 Waveform Recording Menu



20.1 Common Settings

Recording Operation

Click or tap the ON/OFF tab for the **Record** menu to enable or disable the waveform recording function. Before recording the waveform, you can refer to descriptions in *Record Options* to set the waveform recording parameters.



- Click or tap the **Record** button  under the **Record** menu to start recording the waveforms. Then the record icon turns  from .
- During the recording, you can view the recording information under the **Play** menu. In the **Play** menu, the input field of **Current** shows the number of currently recorded frames. Under **Current** is the play progress bar. The left input field is the start frame and the right input field is the total number of currently

recorded frames. ΔT indicates the time interval between the current frame and the first frame during the recording process.

- After the recording is completed,  turns out to be  and recording stops automatically.
- During recording, you can also click or tap  to suspend recording manually.

Play Operation

Click or tap the play icon  under **Play** to start playing the recorded waveforms.

Then the play icon turns from the play action  to the pause action . For details about playing, refer to descriptions in *Play Options*. During waveform playing, the value of **Current** changes dynamically. During playing, you can also click or tap the icon  again to suspend playing manually.

20.2 Record Options

During the waveform recording, the oscilloscope records the waveforms of the currently enabled channel at a specified interval until you manually stops the recording operation or the number of recorded frames has reached the set value.

Before recording the waveforms, set the following parameters.

1. Interval

The recording interval indicates the time interval between the frames during the recording process.

Click or tap **Interval**, then use the pop-up numeric keypad to set the time interval between frames. The available range is from 10 ns to 1 s.

2. Frames

The recording frames refer to the number of frames that can be recorded actually. After starting the recording operation, the oscilloscope stops the recording operation automatically when the number of recorded frames reaches the set value.

Click or tap **Frames** to set the number of waveform frames to be recorded currently. The range available is from 1 to the maximum number of frames that can be recorded currently.

3. Max Frames

The input field of **Max Frames** displays the maximum number of frames that can be recorded currently. Click or tap **Max**, and the maximum number of recorded waveform frames is automatically input into the input field of **Frames**.

As the capacity of the waveform memory is fixed, the more the number of points each frame of waveform has, the less the number of waveform frames that can be recorded. Therefore, the maximum number of recorded frames is related to the currently selected "memory depth" (refer to *Memory Depth*). The current memory depth refers to the number of waveform points per frame. $\text{Memory Depth} = \text{Sample Rate} \times \text{Horizontal Time Base} \times \text{Number of Grids in the Horizontal Direction}$. Therefore, the Max value of waveform recording is also related to the "Sample Rate" and "Horizontal Time Base". This oscilloscope supports up to 2,000,000 frames real-time and ceaseless waveforms recording.

4. Beeper



: the beeper sounds at the end of recording.



: the beeper does not sound at the end of recording.

20.3 Play Options

Waveform playing function can play back the waveforms currently recorded. In **Play** menu, click or tap the ON/OFF tap for the **Minimize** menu to select whether to minimize the window. When you click or tap **ON**, the play window is minimized, making the interface more simplified, easy for observation and operation. As shown in the figure below:

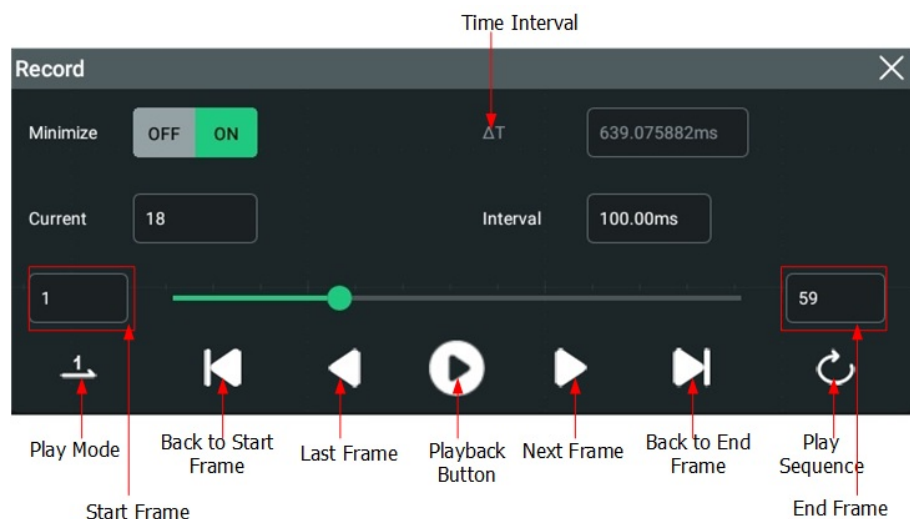



Figure 20.2 Play Operation Interface

Before playing the waveforms, set the following parameters.



1. Play Mode

You can play the waveforms in single mode () or cycle mode (.

- : plays from the start frame to the end frame, and then stops automatically.
- : plays from the start frame to the end frame, then such playback operation is repeated until you stop it manually.

2. Play Sequence

You can play back the waveforms clockwise () or counterclockwise (.

- : plays from the start frame to the end frame.
- : plays from the end frame to the start frame.

3. Interval

The playback interval indicates the time interval between the frames during the playing process.

Click or tap **Interval**, then use the pop-up numeric keypad to set the time interval between frames. The available range is from 1 ms to 10 s.

4. Start Frame

Click or tap the input field of "Start Frame" in *Figure 20.2* to set the start frame for playing back the waveforms. The default is 1, and the maximum value is the maximum number of frames recorded.

5. End Frame

Click or tap the input field of "End Frame" in *Figure 20.2* to set the end frame for playing back the waveforms. The default is the number of frames of the recorded waveforms.

21 Search and Navigation Function

The search function can help you quickly locate the concerned events and make a mark. Then, you can use the specific navigation arrow keys to quickly locate the specified event, time, or frame segment (currently unavailable).

The navigation function guides users to quickly locate and view the specified waveforms. You can navigate by time, event, and frame segment (currently unavailable).

21.1 Search Function

The search function allows you to search the specified waveforms by time, search event, or frame segment (unavailable currently), then marks it with an upside-down triangle icon (▼). To enter the search interface, click or tap the function navigation icon at the lower-left corner of the screen , then click or tap **Search**. You can also click or tap the **Navigate** icon on the quick operation toolbar to enter the navigation interface, then click or tap **Search** to go to the search interface. The search menu is shown in the following figure.

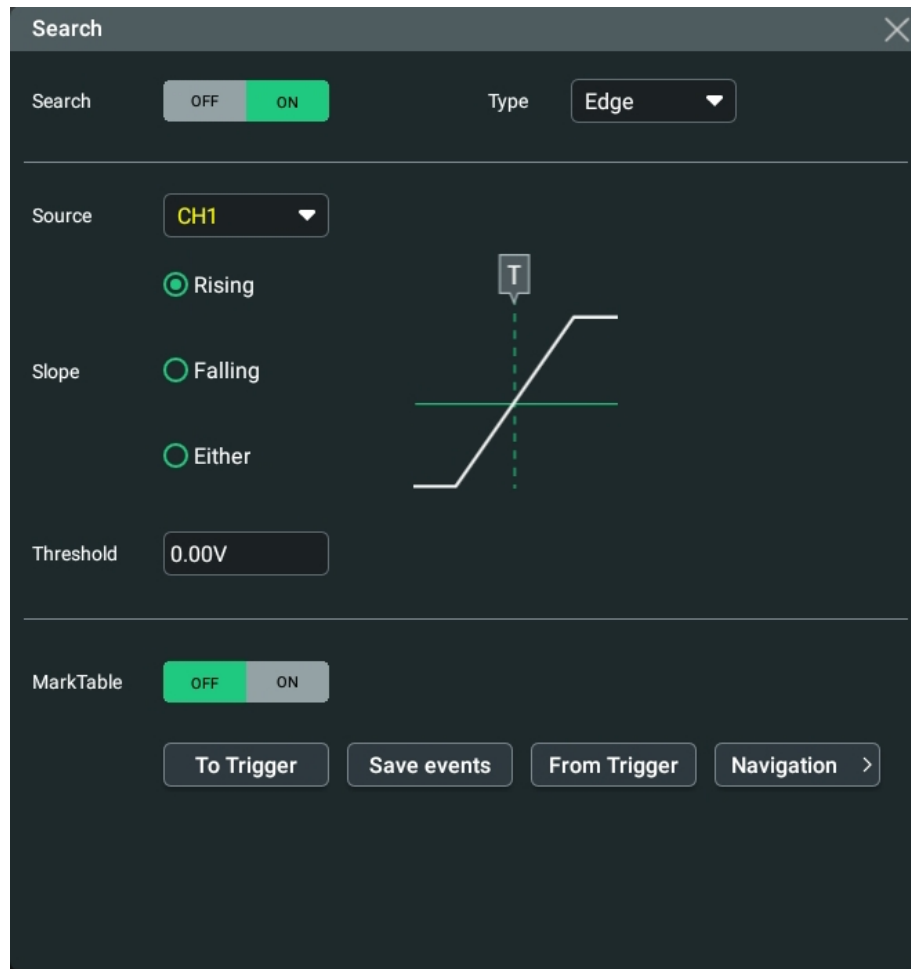

Figure 21.1 Search Menu

1. Enable or disable the search function

Click or tap the ON/OFF tab for the **Search** menu to enable or disable the search function.



TIP

When the search function is enabled, *Delayed Sweep* is automatically enabled.

2. Select the search type and set the parameters

Click or tap the drop-down button of **Type** to select the desired search type (Edge or Pulse).

- Edge search

Click or tap the drop-down button of **Source** to select the desired source (CH1~CH4) for the Edge search.

The edge types can be Rising, Falling, or Either. For details, refer to *Edge Type*.

Click or tap the input field of **Threshold** to set the threshold with the pop-up numeric keypad. You can also use the specified knob to set it.

- **Pulse search**

Click or tap the drop-down button of **Source** to select the source (CH1~CH4) for the Pulse search.

Click or tap  (Positive) or  (Negative) to set the polarity.

Click or tap to select the search conditions. They can be ">", "<", or "< >".

Under different polarities and search conditions, the trigger conditions for pulse signals are different. For details, refer to *Trigger Condition*.

Click or tap the input field of **Threshold** to set the threshold with the pop-up numeric keypad. You can also use the specified knob to set it.

Click or tap the input field of **Upper** or **Lower** to set the upper limit or the lower limit with the pop-up numeric keypad. You can also use the specified knob to set it. For details, refer to *Pulse Width Setting*.

3. Copy to Trigger

- **Copy to Trigger**

Click or tap **To Trigger** to copy the selected search type settings to the same trigger type. For example, if the current search type is "Edge", click or tap **To Trigger** to copy the edge search settings to the "*Edge Trigger*" settings.

- **Copy from Trigger**

Click or tap **From Trigger** to copy the trigger settings of the selected search type to the search settings. For example, if the current trigger type is "*Edge Trigger*", click or tap **From Trigger** to copy the Edge trigger settings to the "Edge" search settings.



NOTE

If you select "From Trigger", you need to set the search type first, and then copy the trigger type settings from the trigger menu.

4. Enable or disable the marker table

Click or tap the ON/OFF tab for the **MarkTable** menu item to enable or disable the marker table. When enabled, the marker table is shown in the following figure. The marker table lists the marker events of the displayed waveforms in the current waveform view. When you zoom or adjust the waveforms, the events in the marker table will change. You can perform the following operations on the marker table.

- When the instrument is in STOP status, click or tap any row in the marker table to select the specified event. The upside-down triangle that marks the selected event turns red (.

- Click or tap the icon  at the upper-right corner of the marker table to open the Search menu.
- Long clicking or tapping the marker table header in gray can move the position of the table on the screen.
- Click or tap the icon  at the upper-right corner of the table to close the marker table.

Index	Time	EventCount	Info
1	-50us	1	Rising edge
2	-49.59us	1	Rising edge
3	-48.79us	1	Rising edge
4	-47.99us	1	Rising edge
5	-47.19us	1	Rising edge
6	-46.39us	1	Rising edge
7	-45.59us	1	Rising edge
8	-44.79us	1	Rising edge
9	-43.99us	1	Rising edge
10	-43.19us	1	Rising edge

Figure 21.2 Marker Table

5. Save events

You can save the event marker data to the internal memory or external USB storage device in "*.csv" format.

Click or tap **Save events** to enter the event saving interface. Please refer to descriptions in "*To Save a File*" to save the event marker data to the internal or external memory.



NOTE

This series oscilloscope only supports the flash memory USB storage device of FAT32 format.

21.2 Navigation Function

The navigation function includes the time navigation, search event navigation, and frame segment navigation. To enter the **Navigation** interface, perform any of the following operations:

- Click or tap the **Navigate** icon on the toolbar at the upper-right part of the screen to enter the Navigation menu.

- In *Search Function*, click or tap the **Navigation** button to enter the Navigation setting menu.

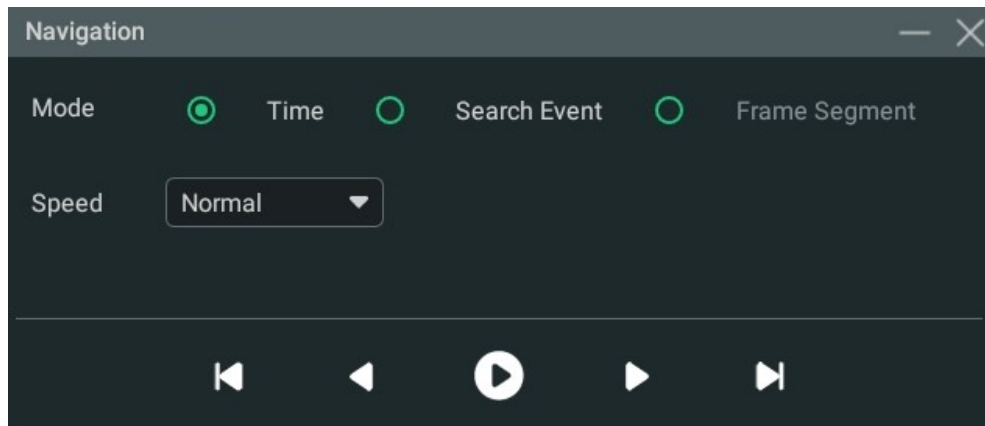



Figure 21.3 Navigation Menu

The navigation interface is shown in *Figure 21.3*. Clicking or tapping the icon  can minimize the Navigation window, making the interface more explicit, as shown in the figure below.

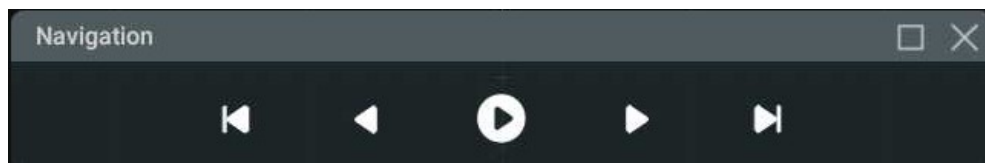







Figure 21.4 Navigation Menu-Simple Mode

TIP

The navigation function is only available when the running status is STOP.

Time Navigation

The time navigation is available only in "YT" mode. The time navigation interface is shown in *Figure 21.3*.

After selecting time navigation, click or tap  to start/pause playing. During the play, click or tap  to play backward; click or tap  to play forward. When it played until stopped, click/tap  or  to move backward or forward the waveforms. Click or tap the drop-down button of **Rate** to select the play rate of the waveforms.

Search Event Navigation

When you enable the navigation function and complete the event search, you can use the navigation combination keys to quickly navigate the specific event in the event mark table. The search event navigation interface is shown in *Figure 21.5*.

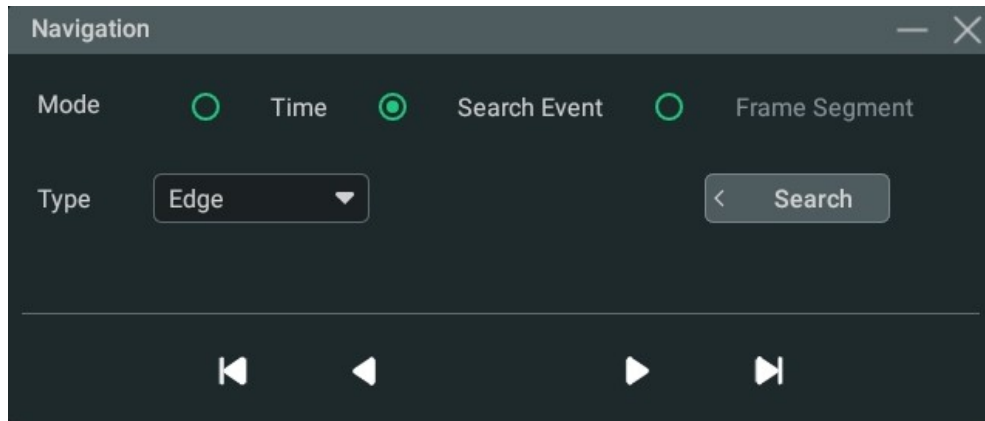





Figure 21.5 Search Event Navigation Interface



After selecting the "Search Event" navigation, click or tap **Search** to set the search conditions. For the search parameters settings, refer to *Search Function*. To select the search type for the event search navigation, click or tap the drop-down button of **Types** to select the desired search type. Click or tap  to navigate to the previous event (the serial number in the mark table decreases); click or tap  to navigate to the next event (the serial number in the mark table increases); click or tap  to go to the first event; click or tap  to go the last event.





Frame Segment Navigation (Currently Unavailable)

The frame segment navigation is only available when the *Acquisition Mode* is set to UltraAcquire. Once in UltraAcquire mode, the **Mode** under **Navigation** menu is, by default, set to **Frame Segment** and cannot be modified to other modes.

- Click or tap the input field of **Start Frame** and **End Frame** to set the frame range for navigation. You can also use the multi-function knob to set them.

When you click or tap the Play icon, it will play from the start frame, and the frame segment displayed on one page is calculated according to the formula (stop frame - start frame + 1). For example, if you set the start frame to 3 and the stop frame to 9, it will play from Frame 3 and each page displays 7 frame segments of waveforms when you play the waveforms.

- Click or tap  to play the frame segments according to the set **Start Frame** and **End Frame**. During playing, you can click or tap  to play one frame backward

or  to play one frame forward. When it played backward or forward to the end, it will stop playing automatically. When it stops playing, click or tap  to go to the previous page; click or tap  to go to the next page. Click or tap  to go to the first page; click or tap  to go to the last page. The current page of the total pages is shown in **Current Page**.

**TIP**

While playing the frame segments, you cannot set the start frame or the end frame.

22 Display Control

In the **Display** setting menu, you can set the type, persistence time, waveform intensity, grid type, grid brightness, and etc.

- Click or tap the function navigation icon  at the lower-left corner of the screen, and then select **Display** to enter the "Display" menu.
- Tap the **Display** icon on the secondary screen at the right side of the screen to enter the "Display" menu.

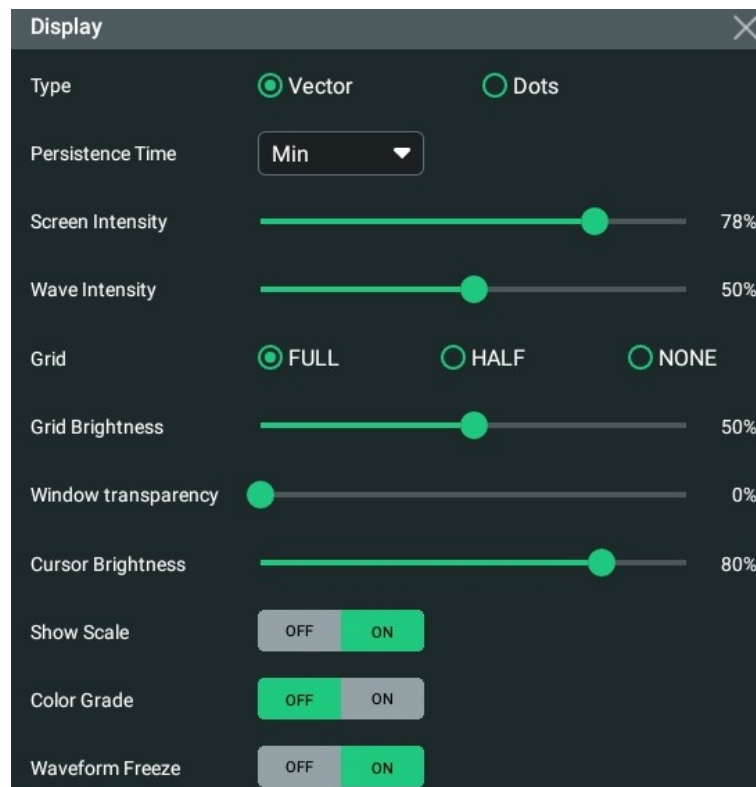

Figure 22.1 Display Setting Menu

22.1 Display Type

In the **Display** setting menu, click or tap "Vector" under **Type** to select the waveform display mode.

For the Vector type, the sample points are connected by lines and displayed. In most cases, this mode can provide the most vivid waveform for you to view the steep edge of the waveform (such as square waveform).

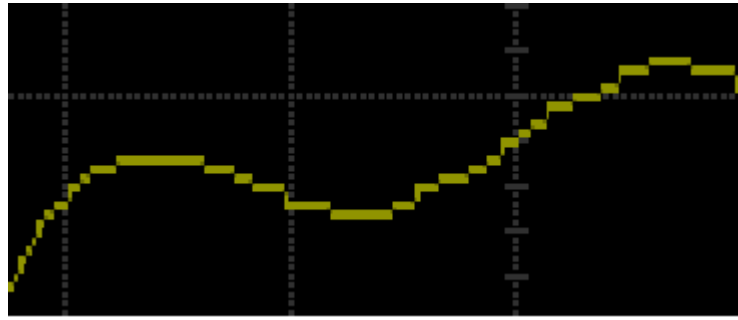

Figure 22.2 Vector Display

22.2 Persistence Time

In the **Display** setting menu, click or tap the drop-down button of **Persistence Time** to select the persistence time from the drop-down list. The available values are Min, specific values (i.g. 100 ms, 200 ms, 500 ms, 1 s, 2 s, 5 s, 10 s), and Infinite.

In the following part, a frequency sweep signal of the sine waveform is used to show the waveform effects in different persistence times.

- **Min**

Enables you to view waveform changing in high refresh rate.

- **Specific Values**

Enables to view glitches that change relatively slowly or glitches with lower occurrence probability. The persistence time can be set to 100 ms, 200 ms, 500 ms, 1 s, 2 s, 5 s, or 10 s.

- **Infinite**

In this mode, the oscilloscope displays the waveform newly acquired without clearing the waveforms acquired formerly. The waveforms acquired formerly will be displayed in relatively low-brightness color and the newly acquired waveforms will be displayed in normal brightness and color. Infinite persistence can be used to measure noise and jitter and to capture incidental events.

22.3 To Set the Screen Grid

In the **Display** setting menu, click or tap "FULL", "HALF", or "NONE" for the **Grid** menu.



- **FULL:** turns the background grid and coordinate on.

- **HALF:** turns the background grid off.
- **NONE:** turns the background grid and coordinate off.

22.4 Display Setting

Screen Intensity

In the **Display** setting menu, drag the slide bar of **Screen Intensity** to set the screen intensity. The default is 78%, and the range available is from 0% to 100%.

Wave Intensity

In the **Display** setting menu, drag the slide bar of **Wave Intensity** to set the waveform intensity. The default is 50%, and the range available is from 1% to 100%.

Grid Brightness

In the **Display** setting menu, drag the slide bar of **Grid Brightness** to set the grid brightness. The default is 50%, and the range available is from 0% to 100%.

Window Transparency

In the **Display** setting menu, drag the slide bar of **Window transparency** to set the window transparency. The default is 50%, and the range available is from 0% to 100%.

Cursor Brightness

In the **Display** setting menu, drag the slide bar of **Cursor Brightness** to set the cursor brightness. The default is 80%, and the range available is from 0% to 100%.

22.5 Show Scale

In the **Display** setting menu, click or tap the ON/OFF tab for the **Show Scale** menu to enable or disable scale display on the screen. By default, it is ON.

22.6 Color Grade

In the **Display** setting menu, click or tap the ON/OFF tab for the **Color Grade** menu to enable or disable the color grade display of the analog channel waveforms on the screen. By default, it is OFF.

When enabled, different colors are displayed on the screen to indicate the times of data acquisition or acquisition probability.

22.7 Waveform Freeze

In the **Display** setting menu, click or tap the ON/OFF tab for the **Waveform Freeze** menu to enable or disable the waveform freeze function. By default, it is ON.

When enabled, the oscilloscope displays the waveform after multiple sampling and superposition when sampling is stopped by clicking or tapping the **STOP/RUN** icon at the upper-left part of the screen. If disabled, the last triggered waveform is displayed.

23 Storage

You can save the current setups, waveforms, screen image, and parameters of the oscilloscope to the internal memory or external USB storage device (such as USB storage device) in various formats and load the stored setups or waveforms when needed. Also you can load the upgrade software to the system and perform the upgrade operation for the instrument.

You can also copy, delete, or rename the specified type of file from the internal memory or external USB storage device via the disk management menu.

This oscilloscope provides one USB HOST interface on the front panel and two USB HOST interfaces on the rear panel, which can all be connected to the USB storage device for external storage. The USB storage devices connected are marked as "Removable USB Disk (D)", "Removable USB Disk (E)", "Removable USB Disk (F)".



TIP

This oscilloscope only supports the flash memory USB storage device of FAT32 format.

To enter the storage setting menu, perform the following operations:

- Click or tap the function navigation icon  at the lower-left corner corner of the screen, and then select **Storage** to enter the storage setting menu.
- Tap the **Storage** icon on the small screen to enter the storage setting menu.
- Click or tap the **Storage** icon in the quick operation bar of the large screen to enter the storage setting menu.

In the **Storage** setting menu, there are three sub-menus (Save, Load, and Upgrade) for you to choose. Click or tap to enter the specified sub-menu and configure the corresponding parameters.

23.1 To Save a File

In the **Storage** menu, click or tap the **Save** tab to enter the save setting menu. In this menu, you can save the image, waveform, or setup files.

23.1.1 To Save Image

In the **Storage** menu, click or tap the **Save** tab to enter the save operation menu. In this menu, click or tap the drop-down button of **Choose** to select "**Save Image**" to enter the "Save Image" setting menu. Set the relevant parameters and save the image to the internal or external memory.

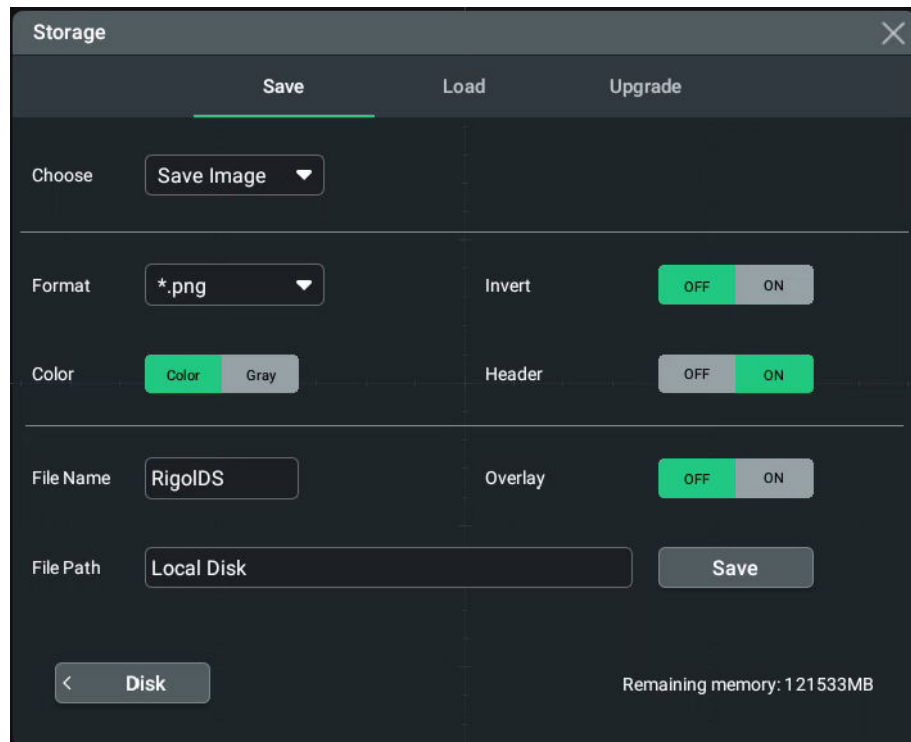

Figure 23.1 Save Image Menu

Set the Image Format

- **Format:**

Click or tap the drop-down button of **Format** to select **".png"**, **".bmp"**, or **".jpg"** from the drop-down list. Then the screen image will be saved to the internal or external memory in ".png", ".bmp", or ".jpg" format.

- **Invert:**

Click or tap the ON/OFF button for the **Invert** menu to enable or disable the waveform invert function.

- **Color:**

Click or tap **"Color"** or **"Gray"** for **Color** to select the desired storage color.

- **Header:**

Click or tap the ON/OFF tab for the **Header** menu to enable or disable the display of the header. If you select "ON", the instrument model and the image creation date will be displayed in the header of the image when you save the image file.

Set the File Saving Parameters

- **Set the filename**

Click or tap the input field of **File Name** to input the file name to be saved with the pop-up virtual keypad.

- **Set the file path**

Click or tap the input field of **File Path**, then the disk management interface is displayed. You can click or tap the saved file to view the saved image file. For detailed operations, refer to descriptions in *Disk Management*.

- **Overlay**

Click or tap the ON/OFF button for the **Overlay** menu to enable or disable the overwriting function. When enabled, the existing file in the specified file path will be overwritten by the newly saved file that has the same filename as the existing one.

After a USB storage device (FAT32, Flash type) is connected, press  on the front panel to make a quick save. If no external USB device is found to be connected to instrument, the file is saved to the internal memory by default. If an external USB device is connected, the file is saved to the USB device by default.

23.1.2 To Save Wave

In the **Storage** menu, click or tap the **Save** tab to enter the save operation menu. In this menu, click or tap the drop-down button of **Choose** to select "**Save Wave**" to enter the "Save Wave" setting menu. The main setting information (e.g. "On/Off" state of the channel, vertical scale, and horizontal time base) and waveform data of all enabled channel will be save to the internal or external memory.

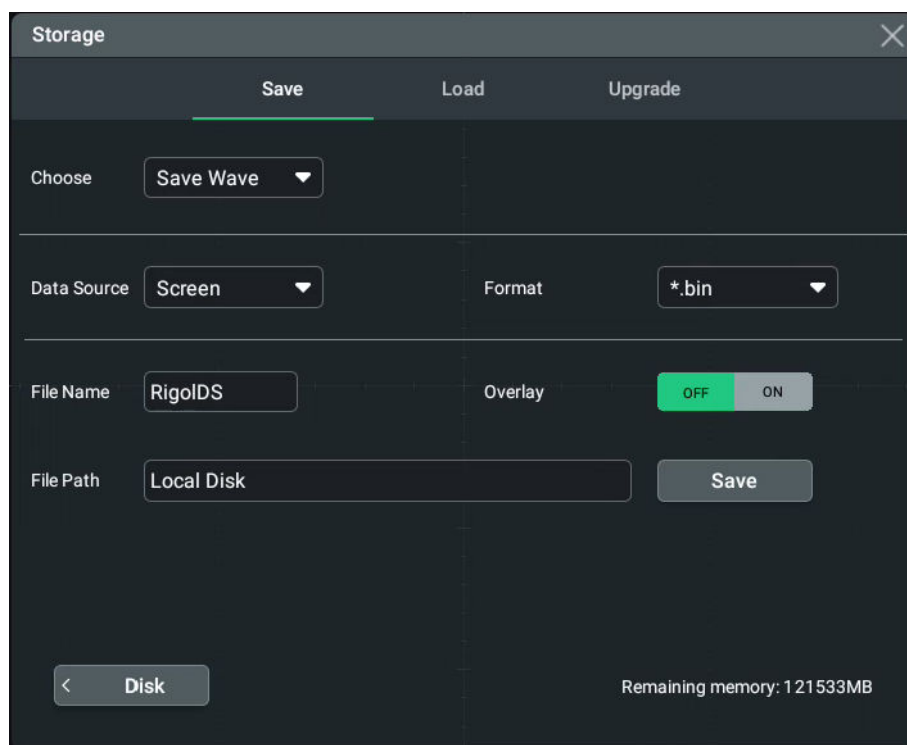

Figure 23.2 Save Wave Menu

Set the Source of the Waveform Data and the Format of the Saved Waveform

- **Data Source**

Click or tap the drop-down button of **Data Source** to select "Screen" or "Memory" from the drop-down list.

- **Waveform Format**

Click or tap the drop-down button of **Format** to select "*.bin" or "*.csv" as the format of the saved waveform.

Set the File Saving Parameters

- **Set the filename**

Click or tap the input field of **File Name** to input the file name to be saved with the pop-up virtual keypad.

- **Set the file path**

Click or tap the input field of **File Path**, then the disk management interface is displayed. You can click or tap the saved file to view the saved image file. For detailed operations, refer to descriptions in *Disk Management*.

- **Overlay**

Click or tap the ON/OFF button for the **Overlay** menu to enable or disable the overwriting function. When enabled, the existing file in the specified file path will be overwritten by the newly saved file that has the same filename as the existing one.

After a USB storage device (FAT32, Flash type) is connected, press  on the front panel to make a quick save. If no external USB device is found to be connected to instrument, the file is saved to the internal memory by default. If an external USB device is connected, the file is saved to the USB device by default.

23.1.3 Save Setup

In the **Storage** menu, click or tap the **Save** tab to enter the save operation menu. In this menu, click or tap the drop-down button of **Choose** to select "**Save Setup**" to enter the "Save Setup" setting menu. Save the settings of the oscilloscope to the internal or external memory in "*.stp" format. When loading, the stored settings can be recalled.

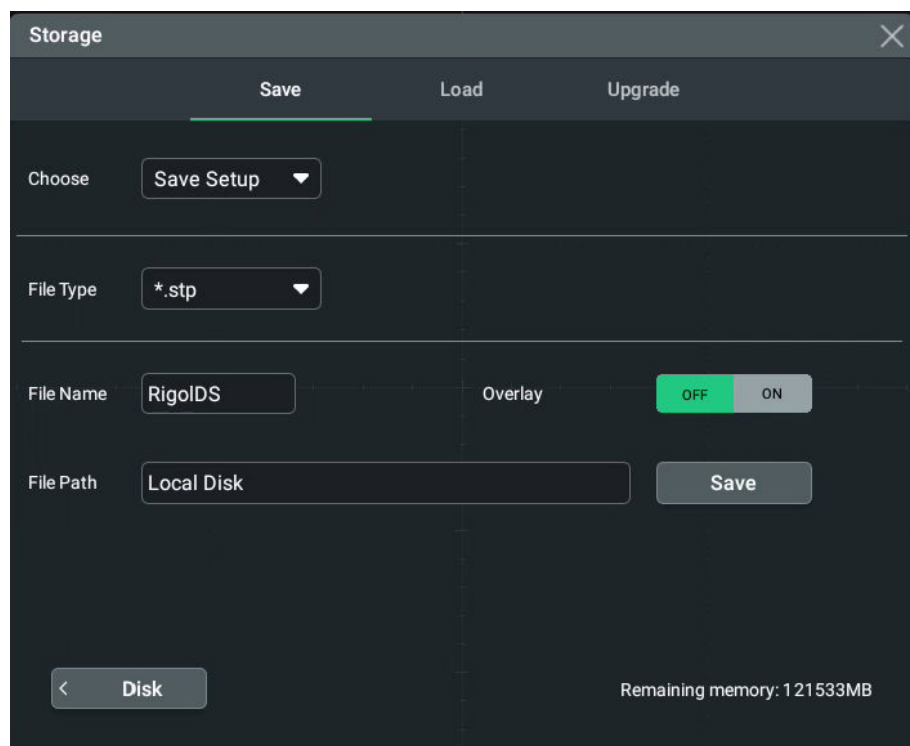

Figure 23.3 Save Setup Menu

Set the File Saving Parameters

- **Set the filename**

Click or tap the input field of **File Name** to input the file name to be saved with the pop-up virtual keypad.

- **Set the file path**

Click or tap the input field of **File Path**, then the disk management interface is displayed. You can click or tap the saved file to view the saved image file. For detailed operations, refer to descriptions in *Disk Management*.

- **Overlay**

Click or tap the ON/OFF button for the **Overlay** menu to enable or disable the overwriting function. When enabled, the existing file in the specified file path will be overwritten by the newly saved file that has the same filename as the existing one.

After a USB storage device (FAT32, Flash type) is connected, press  on the front panel to make a quick save. If no external USB device is found to be connected to instrument, the file is saved to the internal memory by default. If an external USB device is connected, the file is saved to the USB device by default.

23.1.4 Binary Data Format (.bin)

Binary data format stores waveform data in binary format and provides data headers that describe these data. As data are displayed in binary format, its file size is much more smaller than that in ASCII format. If several channels are enabled, then all the displayed channels will be saved (save the first channel then save the second, and then it goes on like this until all the displayed channels are saved).

Table 23.1 BIN File Format

File Header	Waveform Header	Waveform Data Header	Channel Data	Waveform Header	Waveform Data Header	Channel Data
12 Bytes	128 Bytes	12 Bytes	n Bytes	128 Bytes	12 Bytes	n Bytes

In BIN file format, it contains the following channel data:

- CH1 Data
- CH2 Data
- CH3 Data
- CH4 Data
- Math Waveform Data

Binary Header Format

1. File Header

There is only one file header in a binary file. The file header contains the following information.

Table 23.2 File Header

Cookie	Two-byte characters, RG, indicating that the file is the RIGOL binary data file format.
Version	Two-byte, indicating the file version.
File Size	4-byte integer, indicating the number of bytes in the file. It includes the header.
Number of Waveforms	A 4-byte integer, indicating the number of waveforms that are stored in the file.

2. Waveform Header

It is possible to store several waveforms in the file. Each stored waveform has a waveform header. When several channels are stored, each channel can be considered as a separate waveform. The waveform header contains the information about the type of waveform data that are stored following the waveform data header.

Table 23.3 Waveform Header

Header Size	A 4-byte integer, indicating the number of bytes in the header.
Waveform Type	A 4-byte integer, indicating the type of the waveform stored in the file. 0 = Unknown 1 = Normal 2 = Peak Detection 3 = Average 4 = Not Used 5 = Not Used 6 = Logic
Number of Waveform Buffers	A 4-byte integer, indicating the number of waveform buffers required to read the data.
Number of Points	A 4-byte integer, indicating the number of waveform points in the data.

Count	A 4-byte integer, indicating the number of hits at each time interval during waveform recording when using a certain sample mode (e.g. Average) to create the waveforms. For example, when averaging, a count of 4 indicates that each waveform data point in the waveform recording has been averaged at least 4 times. The default value is 0.
X Display Range	A 4-byte float, indicating the X-axis duration of the waveform that is displayed. For time-domain waveforms, it indicates the duration of time across the display. If the value is zero, then no data has been acquired.
X Display Origin	A 8-byte double, indicating the X-axis value at the left edge of the screen. For time-domain waveforms, it indicates the time at the start of the display. The value is treated as a double precision 64-bit float point number. If the value is zero, then no data has been acquired.
X Increment	A 8-byte double, indicating the duration between data points on the X axis. For time-domain waveforms, it indicates the time between points. If the value is zero, then no data has been acquired.
X Origin	A 8-byte double, indicating the X-axis value of the first data point in the data recording. For time-domain waveforms, it indicates the time of the first point. The value is treated as a double precision 64-bit float point number. If the value is zero, then no data has been acquired.
X Units	<ul style="list-style-type: none"> - A 4-byte integer, indicating the unit of measurement for X values in the acquired data. - 0 = Unknown - 1 = Volts (V) - 2 = Seconds (s) - 3 = Constant - 4 = Amps (A) - 5 = dB - 6 = Hz
Y Units	A 4-byte integer, indicating the unit of measurement for Y values in the acquired data. The possible values are listed above under X Units.
Date	A 16-byte character array, not used
Time	A 16-byte character array, not used

Frame	A 24-byte character array, indicating the model number and serial number of the oscilloscope in the format: MODEL#:SERIAL#.
Waveform Label	A 16-byte character array that contains the label assigned to the waveform.

3. Waveform Data Header

A waveform may have multiple data sets. Each waveform data set has a waveform data header. The waveform data header consists of information about the waveform data set. The header is stored before the data set.

Table 23.4 Waveform Data Header

Header Size	A 4-byte integer, indicating the number of bytes in the waveform data header.
Buffer Type	<ul style="list-style-type: none"> - A 2-byte integer, indicating the type of the waveform data stored in the file. - 0 = Unknown - 1 = Normal 32-bit float data - 2 = Maximum float data - 3 = Minimum float data - 4 = Not Used - 5 = Not Used - 6 = Digital unsigned 8-bit character data (for digital channels)
Bytes Per Point	A 2-byte short integer, indicating the number of bytes per data point.
Buffer Size	4-byte integer, indicating the size of the buffer required to hold the data points.

23.2 To Load a File

In the storage setting menu, click or tap the **Load** tab to switch to the load menu. In this menu, you can load the local file to the instrument.

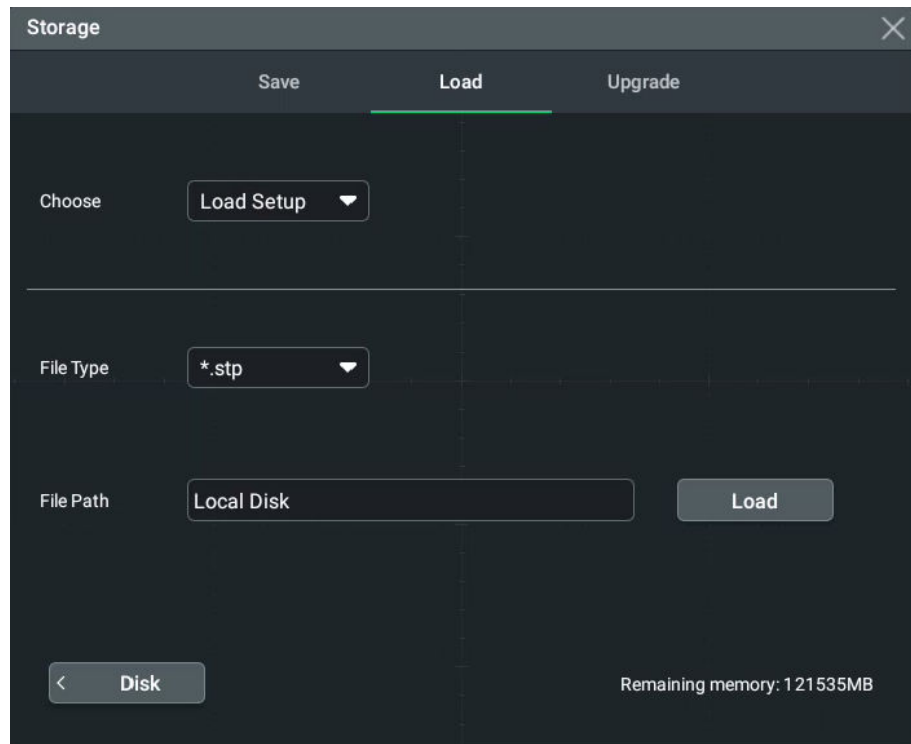

Figure 23.4 Load Setting Menu

Load Setup

Click or tap the drop-down button of **Choose** to select "Load Setup". Then, click or tap **File Path** to load the setup file (suffixed with "*.stp") from the internal memory or the external USB disk. Select the file to be loaded from the memory. Click or tap **Load** to load the selected file.

23.3 System Upgrade

This instrument supports local upgrade and online upgrade.

Local Upgrade

1. In the storage setting menu, click or tap **Upgrade** to enter the local upgrade setting menu.

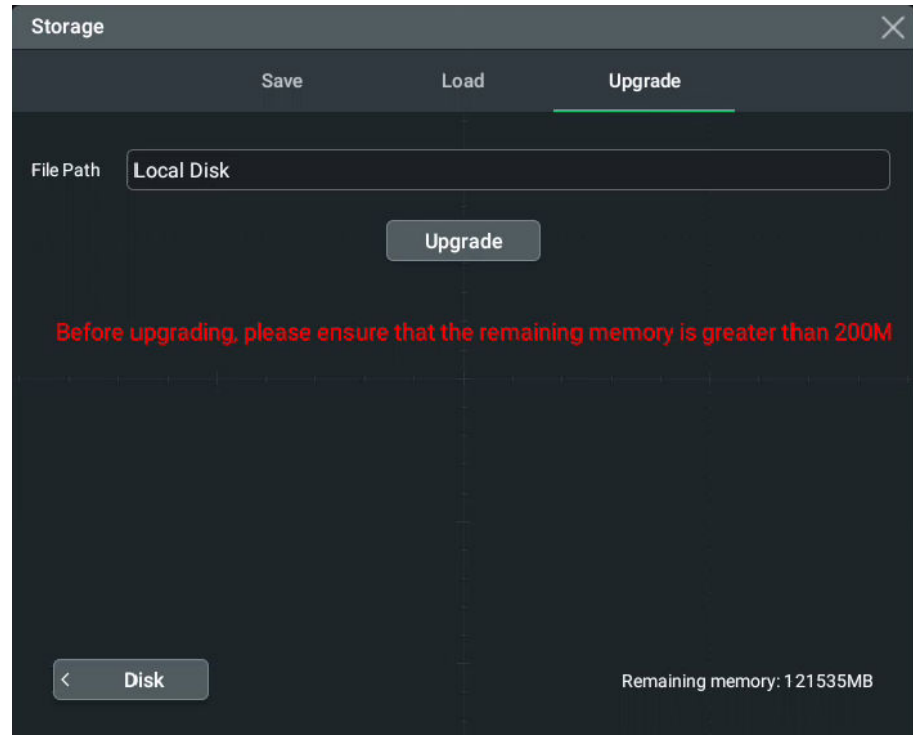



Figure 23.5 Upgrade Menu

2. Click or tap the input field of **File Path**, then the disk management interface is displayed. Select the upgrade file. For detailed operations, refer to the descriptions in *Disk Management*.
3. Click or tap **Upgrade** to complete the local upgrade.

Online upgrade

1. Ensure that the rear-panel LAN interface is connected to the network (if you do not have the access to the Internet, please ask the administrator to grant you the authority to access the network).
2. Click or tap the function navigation icon  at the lower-left corner of the screen to enter the function navigation. Click or tap **Upgrade** to perform the upgrade operation.

23.4 Disk Management

To enter the storage setting menu, perform the following operations:

- Click or tap the function navigation icon  at the lower-left corner corner of the screen, and then select **Storage** to enter the storage setting menu.
- Tap the **Storage** icon on the small screen at the right side of enter the storage setting menu.

- Click or tap the **Storage** icon at the top of the screen to enter the storage setting menu.

Then click or tap **Disk** at the lower-left corner of the "Storage" menu to enter the disk management interface, as shown in the figure below.

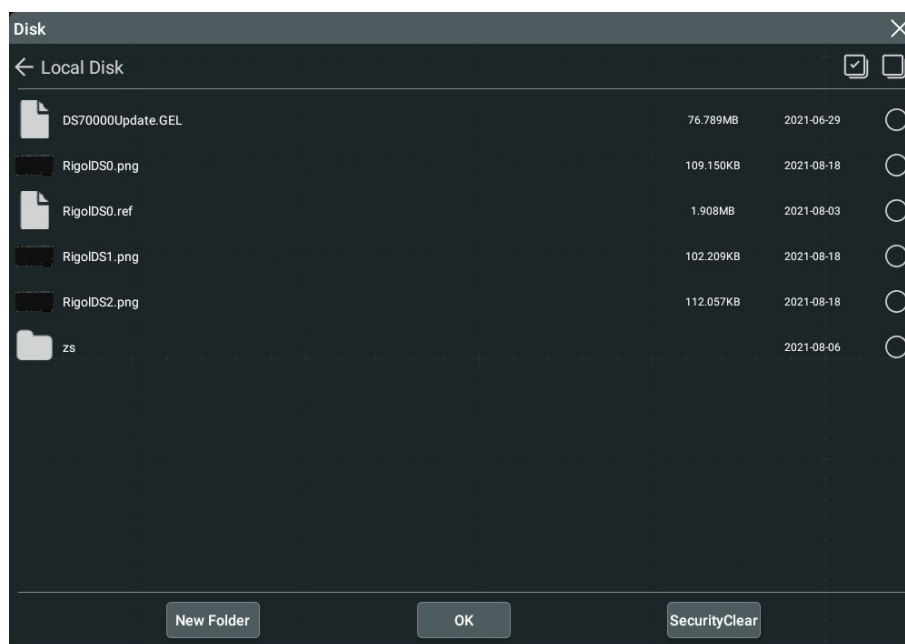

Figure 23.6 Disk Management Interface

Execute the following operations through the disk management menu:

Select a Disk

Before using the external storage device, make sure that a USB storage device (FAT32 format, flash memory) is connected correctly.

By default, the "Local Disk(C)" is selected. If an external storage device is inserted, under the "Disk" menu, two available storage disks can be selected at the upper-left corner of the "Disk" interface: Local Disk (C) and Removable USB Disk (D). If you select an external storage device, for example, if you select "Removable USB Disk (D)", the contents in USB Disk(D) will be displayed.

Create a Folder

Click or tap **New Folder**, then a folder name input keyboard is displayed.



For the methods of using the keypad, refer to descriptions in [Parameter Setting Method](#). Click or tap any place on the screen to exit the keyboard.



Clear the Internal Memory Safely

Click or tap **SecurityClear**, then a prompt message "Execute secure memory wipe?" is displayed. Click or tap **OK** to clear all the files stored in the internal disk. Click or tap **Cancel** to cancel security clear operation.

Select a File

Before operating on the file or folder, first select the desired file or folder.

Click or tap the check box at the right side of the folder, if checked, it is selected, with an icon  being displayed. Click/tap the check box again or click/tap  to deselect it. The check box restores its original state.

DS80000 supports selecting multiple files or folders to operate on. You can also click or tap the icon  at the upper-right corner of the interface to select all the files and folders under the current disk. Click or tap  to cancel the select-all operation.

Cut, Copy, or Paste a File or a Folder

- **Cut a File to a Specified Folder**

Select a specified file or folder. Click or tap **Cut** to cut the specified file or folder. Then select the destination folder. Then click or tap **Paste** to paste the specified file or folder to the destination folder.

- **Copy a File to a Specified Folder**

Select a specified file or folder. Click or tap **Copy** to copy the specified file or folder. Then select the destination folder. Then click or tap **Paste** to paste the specified file or folder to the destination folder.

Delete a File or Folder

In the current folder, select the file or folder to be deleted. Click or tap **Delete**, then a prompt message "Are you sure to delete the file" is displayed. Click or tap **OK** to delete the file. Click or tap **Cancel** to cancel the deletion operation.

Rename a File or Folder

Select a specified file or folder, then click or tap **Rename** to input a new filename or folder name with the pop-up numeric keypad. Then, the rename operation is completed.

23.5 Factory Settings





Press  on the front panel or click/tap the **Default** icon at the top of the screen, then a prompt message "Restore default settings?" is displayed. Click or tap **OK** to restore the instrument to its factory default settings, as shown in the table below.

Table 23.5 Factory Settings

Parameter	Factory Settings
Horizontal	
Horizontal Scale	5 ns
Horizontal Position	0 s
Delayed Sweep	OFF
Roll	Auto
Fine	OFF
Horizontal Expansion	Center
Memory Depth	10 Kpts
Vertical	
VScale	100 mV
VOffset	0 V
CH1	ON
CH2	OFF
CH3	OFF
CH4	OFF
Channel Coupling	DC
BW Limit	OFF
Attenuation	1X
Impedance	50 Ω
Invert	OFF
Fine	OFF
Channel Unit	[V]
Display Label	OFF
Channel Delay	0 s
Bias	0 V
Acquire	
Acquisition Mode	Normal
Memory Depth	Auto
Anti-Aliasing	OFF
Trigger	
Trigger Type	Edge Trigger
Source Selection	CH1
Edge Type	Rising
Trigger Mode	Auto
Trigger Coupling	DC
Trigger Holdoff	8 ns

Parameter	Factory Settings
Noise Rejection	OFF
Display	
Display Type	Vector
Persistence Time	Min
Intensity	50%
Grid	FULL
Grid Brightness	50%
Window Transparency	50%
Show Scale	ON
Color Grade	OFF
Waveform Freeze	ON
Measure	
Mode	Normal
Indicator	OFF
Statistics	OFF
Count	1,000
Threshold Type	%
Threshold Source	CH1
Upper Threshold	90%
Mid Threshold	50%
Lower Threshold	10%
Amplitude Measurement Method	Auto
Region	Main
Save Image	
Overlay	OFF
Header	ON
Format	*.png
Invert	OFF
Color	Color
Save Wave	
Data Source	Screen
Format	*.bin
Save Setup	
File Type	*.stp
Load Setup	
File Type	*.stp
System Setting	
Load last	Default

Parameter	Factory Settings
Beeper	OFF
PF Out	TrigOut
Vibration	ON
Screen Lock	OFF
Expand	GND
Show Time	ON
Other Setting	
Backlight of the Electronic Tag	OFF
EXT 10M IN	OFF
Auto Config	
Peak to Peak	ON
Live CH	OFF
Overlay	ON
Coupling	OFF
Quick Settings	
Operation	Save Image
Format	*.png
Invert	OFF
Color	Color
Pass/Fail Test	
Enable	OFF
Source	CH1
Minimize	OFF
X Mask	240 mdiv
Y Mask	480 mdiv
Format of the Mask File to be Loaded	*.pf
Format of the Mask File to be Saved	*.pf
File Name	RigolDS
PF Out	OFF
Output Event	Fail
Polarity	Positive
Pulse	1 μ s
Error Action	N/A
Waveform Recording	
Waveform Recording	OFF
Record	

Parameter	Factory Settings
Interval	10 ns
Frames	1,000
Beeper	
Play	
Play Mode	
Play Sequence	
Interval	100 ms
Math Operation	
Invert	OFF
Expand	GND
Display Label	OFF
Grid	FULL
A+B	
Operation	OFF
SourceA	CH1
SourceB	CH1
Offset	0 V
Scale	500 mV
A-B	
Operation	OFF
SourceA	CH1
SourceB	CH1
Offset	0 V
Scale	500 mV
A×B	
Operation	OFF
SourceA	CH1
SourceB	CH1
Offset	0 U
Scale	500 mU
A÷B	
Operation	OFF
SourceA	CH1
SourceB	CH1
Offset	0 U
Scale	500 mU
FFT	
Operation	OFF
Source	CH1
Offset	0 dBV

Parameter	Factory Settings
VScale	20 dBV
Unit	dBm/dBV
X	Start-End
Start Freq	0 Hz
Stop Freq	10 MHz
Window Function	Hanning
Color Grade	OFF
Peak Search	OFF
Peak Number	5
Threshold	5.5 dBV
Excursion	1.8 dBV
Table Order	Amp Order
A&&B	
Operation	OFF
SourceA	CH1
SourceB	CH1
Wave Size	Medium
Thre.CH1	0 V
Thre.CH2	0 V
Thre.CH3	0 V
Thre.CH4	0 V
Sensitivity	300 mdiv
Offset	0 div
A B	
Operation	OFF
SourceA	CH1
SourceB	CH1
Wave Size	Medium
Thre.CH1	0 V
Thre.CH2	0 V
Thre.CH3	0 V
Thre.CH4	0 V
Sensitivity	300 mdiv
Offset	0 div
A^B	
Operation	OFF
SourceA	CH1
SourceB	CH1
Wave Size	Medium
Thre.CH1	0 V
Thre.CH2	0 V

Parameter	Factory Settings
Thre.CH3	0 V
Thre.CH4	0 V
Sensitivity	300 mdiv
Offset	0 div
!A	
Operation	OFF
SourceA	CH1
Wave Size	Medium
Thre.CH1	0 V
Thre.CH2	0 V
Thre.CH3	0 V
Thre.CH4	0 V
Sensitivity	300 mdiv
Offset	0 div
Intg	
Operation	OFF
Source	CH1
Scale	500 mV*s
Offset	0 V*s
Bias	0
Diff	
Operation	OFF
Source	CH1
Scale	500 mV/s
Offset	0 V/s
Smooth	5
Sqrt	
Operation	OFF
Source	CH1
Scale	500 mU
Offset	0 U
Lg	
Operation	OFF
Source	CH1
Scale	500 mU
Offset	0 U
Ln	
Operation	OFF
Source	CH1
Scale	500 mU
Offset	0 U

Parameter	Factory Settings
Exp	
Operation	OFF
Source	CH1
Scale	500 mU
Offset	0 U
Abs	
Operation	OFF
Source	CH1
Scale	500 mV
Offset	0 V
Low Pass	
Operation	OFF
Source	CH1
Scale	500 mV
Offset	0 V
ωc	20 MHz
High Pass	
Operation	OFF
Source	CH1
Scale	500 mV
Offset	0 V
ωc	20 MHz
Band Pass	
Operation	OFF
Source	CH1
Scale	500 mV
Offset	0 V
$\omega c1$	20 MHz
$\omega c2$	40 MHz
Band Stop	
Operation	OFF
Source	CH1
Scale	500 mV
Offset	0 V
$\omega c1$	20 MHz
$\omega c2$	40 MHz
AX+B	
Operation	OFF
Source	CH1
Scale	500 mV
Offset	0 V

Parameter	Factory Settings
A	1
B	0
Ref	
Current	Ref1
Source	CH1
VScale	1 V
VOffset	0 V
Label	REF1
Label Display	OFF
Color	Orange

24 System Utility Function Setting

In the **Utility** menu, you can set the I/O parameters and the system-related function parameters. To enter the "Utility" menu, perform the following operations.

- Click or tap the Notification Area at the lower-right corner of the screen. Then the **Utility** menu is displayed.
- Click or tap the function navigation icon  at the lower-left corner of the screen, then select **Utility** to enter the **Utility** menu.
- Tap the **Utility** icon on the small screen at the right side of the screen to enter the **Utility** menu.

24.1 I/O Setting

In **Utility** menu, click or tap **IO** to enter the I/O setting menu to configure the following parameters.

Network Status

Different prompts will be displayed according to the current network connection status.

- Network Config Succeeded!
- Acquiring IP..
- IP Conflict!
- DISCONNECTED!
- DHCP Config Failed
- Read Status Fail!
- CONNECTED
- Invalid IP
- IP lost
- Please wait...

MAC Address

For each instrument, the MAC address is unique. When assigning the IP address for the instrument, the system uses the MAC address to identify the instrument.

VISA Address

Displays the VISA address currently used by the instrument.

IP Configuration Type

The configuration type of the IP address can be DHCP, Auto IP, or Static IP. In different IP configuration types, the configurations for IP address and other network parameters are different.

- **DHCP**

If "DHCP" is selected, the DHCP server in the current network will assign the network parameters (e.g. IP address, Subnet, Gateway, and DNS) for the instrument.

- **Auto IP**

When "Auto IP" is selected, the instrument will acquire the IP address ranging from "169.254.0.1" to "169.254.255.254" and the subnet mask (255.255.0.0) automatically based on the current network configuration. The "Auto IP" works only when "DHCP" is not selected or connection is failed.

- **Static IP**

If "Static IP" is selected, the instrument is configured with static IP. In this case, you need to disable DHCP and Auto IP manually. Then you need to configure the parameters such as "IP address", "Subnet", "Gateway", and "DNS" manually. At this time, you can self-define the network parameters (e.g. IP address) of the instrument.

- **Set the IP address**

The format of the IP address is nnn.nnn.nnn.nnn. The range of the first segment (nnn) of the address is from 0 to 255 (except 127); wherein, the valid range is from 0 to 223. The range for the other three segments is from 0 to 255. You are recommended to ask your network administrator for an IP address available.

This setting will be saved to the non-volatile memory; if "Power On" is set to "Last", then DHCP and Auto IP are disabled at the next power-on. The instrument will load the preset IP address automatically.

- **Set the subnet mask**

The format of the subnet mask is nnn.nnn.nnn.nnn. Wherein, the range of "nnn" is from 0 to 255. You are recommended to ask your network administrator for a subnet mask available.

This setting will be saved in the non-volatile memory; if "Power On" is set to "Last", then DHCP and Auto IP are disabled at the next power-on. The instrument will load the preset subnet mask automatically.

- **Set the default gateway**

You can set this parameter in Static IP mode. The format of the gateway is nnn.nnn.nnn.nnn. The range of the first segment (nnn) is from 0 to 223 (except 127), and the range for the other three segments is from 0 to 255. You are recommended to ask your network administrator for a gate address available.

This setting will be saved in the non-volatile memory; if "Power On" is set to "Last", then DHCP and Auto IP are disabled at the next power-on. The instrument will load the preset gateway automatically.

- **Set the DNS address**

You can set this parameter in Static IP mode. The format of the DNS address is "nnn.nnn.nnn.nnn". The range for the first segment (nnn) of the address is from 0 to 223 (except 127); and the range for the other three segments is from 0 to 255. You are recommended to ask your network administrator for an address available.

Generally, you do not need to set the DNS, therefore this parameter setting can be ignored.



TIP

- When the three IP configuration types are all turned on, the priority of the parameter configuration from high to low is "DHCP", "Auto IP", and "Static IP".
- The three IP configuration types cannot be all turned off at the same time.

mDNS

Click or tap the ON/OFF tab for mDNS to enable or disable the multicast Domain Name System (mDNS). This system is used to provide the function of DNS server for service discovery in a small network without a DNS server.

Host Name

If mDNS is enabled, you need to configure the mDNS host name, supporting inputting a maximum of 26-byte strings.

GPIB

When using the GPIB interface, use the USB-GPIB interface converter(an option that requires to be ordered separately) to extend the GPIB interface, and then use the GPIB cable to connect the instrument to the PC. Configure the GPIB address. Its settable range is from 1 to 30. By default, it is 1.

Apply the Network Parameter Setting

Click or tap **Apply** to validate the current network parameter setting.

24.2 Basic Settings

In the **Utility** menu, click or tap **Setup** to enter the basic setting menu.

Language

This product supports menus in multiple languages. Both Chinese and English are available for the display of the help information, prompt messages, and interface. Click or tap the drop-down button of **Language** to select the specified system language from the drop-down list.

Load last

You can set the system configuration to be recalled when the oscilloscope is powered on again after power-off. Click or tap "Default" or "Last" for **Load last**.

- **Last:** returns to the setting of the system at last power-off.
- **Default:** returns to the factory setting of the system.

Power Status

- **Switch Off:** After the oscilloscope is connected to power, you need to press the Power key on the front panel to power on the instrument.
- **Switch On:** After the the oscilloscope is connected to power, it will be powered on immediately.

Beeper

Click or tap the ON/OFF button for the **Beeper** menu item to enable/disable the beeper. When the beeper is enabled, you can hear the sound of the beeper when you perform the following operations:

- Press any front-panel key or menu key;
- Use the touch screen;
- When a prompt message is displayed.

PF Out

You can select the type of the signal output from the rear-panel **[TRIG/PF Out]** connector by selecting the desired signal type under **PF Out**.

- **TrigOut:** After this type is selected, at each trigger (hardware trigger), the instrument outputs a signal that can reflect the current capture rate of the oscilloscope from the rear-panel **[TRIG/PF Out]** connector. If this signal is connected to a waveform display device to measure the frequency, the found measurement result is the same as the current capture rate.
- **PassFail:** When this type is selected, the instrument outputs a positive or negative pulse via the **[TRIG/PF Out]** connector after a successful or failed event is detected. Refer to descriptions in *To Set the Output Form of the Test Results*. When you enable the PF output, the **PF Out** menu is automatically set to

"PassFail". When the **PF Out** menu is set to "TrigOut", then in the pass/fail test menu, the PF Out function is automatically disabled.

Vibration

Sets whether to vibrate when you perform the touch-enabled operation on the small screen at the right side of the front panel.

Click or tap the ON/OFF button for the **Vibration** menu item to enable/disable the vibration.

Input Lock

Sets whether to lock the front-panel keys and touch screen operation. Once the screen is locked, the touch screen function is disabled, you can no longer operate on the screen.

Click or tap the ON/OFF button for the **Input Lock** menu item to enable or disable the screen operation. After the screen is locked, press the front-panel channel button "1324" in sequence to unlock the screen.

Expand

Click/tap to select whether to expand or compress the waveform around the "Center" or "GND".

- **Center:** when the vertical scale is changed, the waveform will be expanded or compressed around the screen center.
- **GND:** when the vertical scale is changed, the waveform will be expanded or compressed around the signal ground level position.

Show Time

The system time (date and time) is displayed in the Notification Area at the lower-right corner of the screen. The date is displayed in "yyyy/mm/dd" format, and the time is displayed in "hh:mm:ss" format. When you save the waveform, the output file will contain the time information. Users can set the system time.

- **Date:** Click or tap the "Date" area, then the date setting interface is displayed. Select a proper date, then click or tap **OK** to confirm the date modification. Click or tap **Cancel** to cancel date modification and exit the date menu.
- **Time:** Click or tap the "Time" area, then the time setting interface is displayed.
 - Click or tap the Hour/Minute number and then move it up and down to modify the hour and minute.
 - After setting the hour and minute, click or tap **OK** to confirm the setting. Click or tap **Cancel** to cancel the time modification and exit the time menu.

24.3 About this Oscilloscope

In **Utility** menu, click or tap **About**, and then you can view the model, version, and other information about this instrument in **About** menu.

- **Model**
Indicates the product model.
- **Serial number**
Indicates the serial number of the product, the unique identification for the product.
- **Firmware**
Indicates the firmware version number of the product.
- **Hardware**
Indicates the hardware version number of the product.
- **Build**
Indicates the creation time of the software version.
- **Android.Build**
Indicates the creation time of the Android operating system.
- **Android.Version**
Indicates the version number of the Android operating system. For example, 7.1.0.
- **Launcher**
Indicates the desktop UI version number of the Android operating system.
- **WebControl**
Indicates the version number of browser remote control module.

24.4 Other Settings Related to the System Utility

DSP

When enabled, the system will make a digital adjustment for the frequency response of the analog channel to ensure the accuracy of the signals obtained by the oscilloscope.

EXT 10M IN

Indicates the rear-panel **[CLK IN]** clock input interface. Click or tap the ON/OFF tab to enable or disable the interface.

Electronic Tag

When you select ON, the backlight of the electronic tag at the upper-right corner of the front panel is illuminated; when you select OFF, the backlight turns off.

Remove Dust

Click or tap **RUN**, then the fan inside of the instrument runs at a max. speed for 3 s to remove the dust.

24.5 Auto Config

In "Utility" menu, click or tap **Auto Config** to enter the menu in which you can configure the **Auto** function.

- Click or tap **Peak to Peak** on/off switch to enable or disable the peak-to-peak priority setting. This function is intended for the shifted signal. If there is a large deviation, you can view the signal waveform in priority when you enable the function.
- Click or tap **Live CH** on/off switch to turn on/off examining channels that are turned on.

If "OFF" is selected, enable the Auto function and all analog channels will be examined for signal activity in sequence. If no signal is detected for a specified channel, the channel will be turned off; otherwise, if a signal is detected, the channel will be autoscaled to best display the signal. If "ON" is selected, enable the Auto function and only the channels that are turned on will be examined.

- Click or tap **Overlay** on/off switch to enable or disable the waveform overlay display function. If enabled, waveforms of different channels will be displayed in the same position of the screen; if disabled, waveforms of different channels will be displayed on the screen from top to bottom in sequence.
- Click or tap **Keep Coupling** on/off switch to turn on/off maintaining channel coupling. If "ON" is selected, enable the Auto function and the channel coupling setting is maintained; if "OFF" is selected, the channel coupling is DC coupling by default.

24.6 SelfCal

The self-calibration program can quickly make the oscilloscope to work in an optimal state to get the precise measurement results. You can perform self-calibration at any time, especially when the changes of the ambient temperature reach or above 5°C. Make sure that the oscilloscope has been warmed up or operating for more than 30 minutes before the self-calibration.

In "Utility" menu, click or tap **SelfCal**, the following self-calibration interface is shown below.

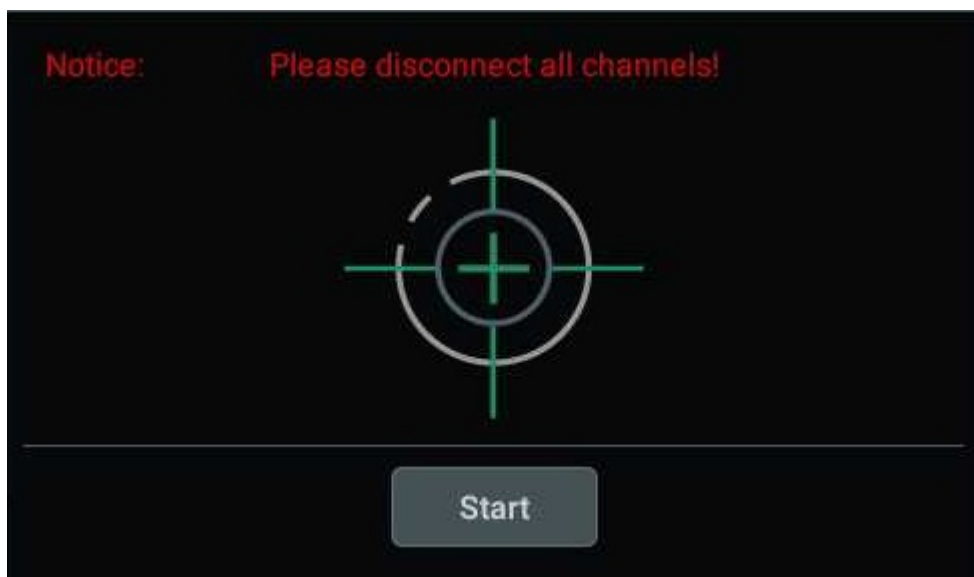

Figure 24.1 Self-calibration Menu

- Click or tap **Start**, and then the oscilloscope will start to execute the self-calibration program.
- After starting the self-calibration program, click or tap **Exit** to cancel self-calibration operation at any time.
- Click or tap **Close** to close the self-calibration information window.

24.7 Option List

In the "Utility" menu, click or tap **Options**, then all the options that have currently been installed can be displayed. For the procedures of installing the options, refer to *To View the Option Information and the Option Installation*.

24.8 Quick Operation

In the **Utility** menu, click or tap **Quick** to enter the quick operation menu.

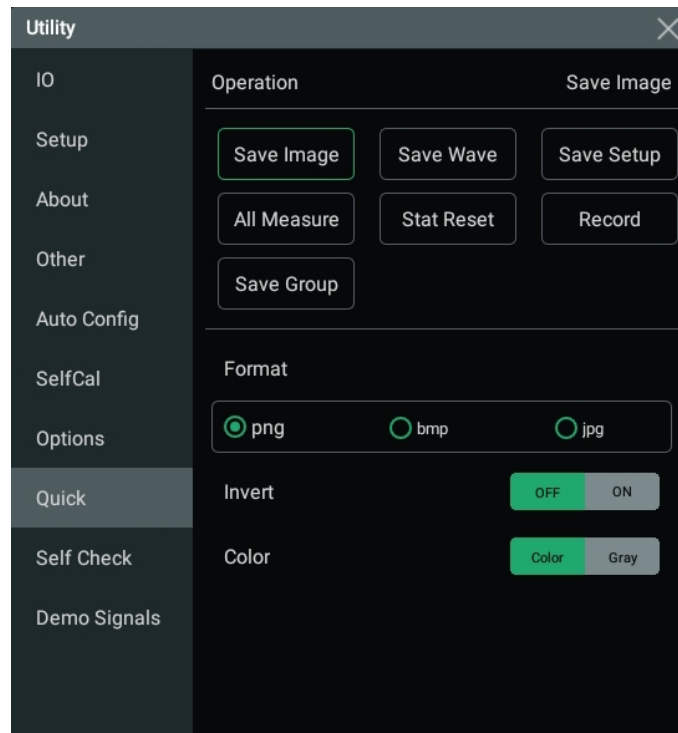



Figure 24.2 Quick Operation Setting Menu

Save Image

- Click or tap **Save Image** to set **Operation** to "Save Screen".
- In the **Format** menu item, the available image type can be **".png"**, **".bmp"**, and **".jpg"**.
- Click or tap the ON/OFF button for the **Invert** menu item to enable or disable the invert function.
- Click or tap **"Color"** or **"Gray"** for **Color** to select the desired storage color.

After setting, click or tap the button  at the right section of the front panel to capture the current screen and save the image based on the settings. The storage location is related to the settings in **File Path** in the storage menu. For the settings of the storage path, refer to *To Save a File*.

Save Wave

- Click or tap **Save Wave**, then **Operation** is set to "Save Wave".
- Click or tap to select **"Memory"** or **"Screen"** under **Data Source** as the source of the saved waveform.
- The available choices under **Format** include **".bin"** and **".csv"**.

After setting, click or tap the button  at the right section of the front panel to save the waveforms based on the settings. The storage location is related to the settings in **File Path** in the storage menu. For the settings of the storage path, refer to *To Save a File*.

Save Setup

Click or tap **Save Setup**, then **Operation** is set to "Save Setup".

After setting, click or tap the button  at the right section of the front panel to save the current instrument settings as a setup file suffixed with "*.stp". The storage location is related to the settings in **File Path** in the storage menu. For the settings of the storage path, refer to *To Save a File*.

All Measurement

- Click or tap **All Measure**, then **Operation** is set to "All Measure".
- In **All Measure** menu item, click or tap the drop-down button to select the measurement channel CH1~CH4.

After setting, click or tap the button  at the right section of the front panel to perform the all measurements on the specified channel.

Reset Statistics

- Click or tap **Stat Reset**, then **Operation** is set to "Stat Reset".
- Under **Stat Reset**, click or tap "Measure" or "Pass/Fail" to reset the statistics of the specified function.

After setting, click or tap the button  at the right section of the front panel, then the statistics of the specified function under the **Result** list at the right side of the screen will be cleared and new measurement will be launched.

Waveform Recording

Click or tap **Record**, then **Operation** is set to "Record".

After setting, click or tap the button  at the right section of the front panel to perform the waveform recording operation.

Save Group

- Click or tap **Save Group**, then **Operation** is set to "Save Group".
- Under **Save Group**, select one or multiple items from "Save Image", "Save Wave", and "Save Setup".

After setting, click or tap the button  at the right section of the front panel to save the specified items based on the settings. The storage location is related to the settings in **File Path** in the storage menu. For the settings of the storage path, refer to *To Save a File*.

24.9 Self-check

In **Utility** menu, click or tap **Self Check** to enter the "Self Check" setting menu. You can test the following self-check items for the device.

Key Test

Click or tap **Key Test** to enter the key test interface (virtual front panel key), as shown in the figure below.

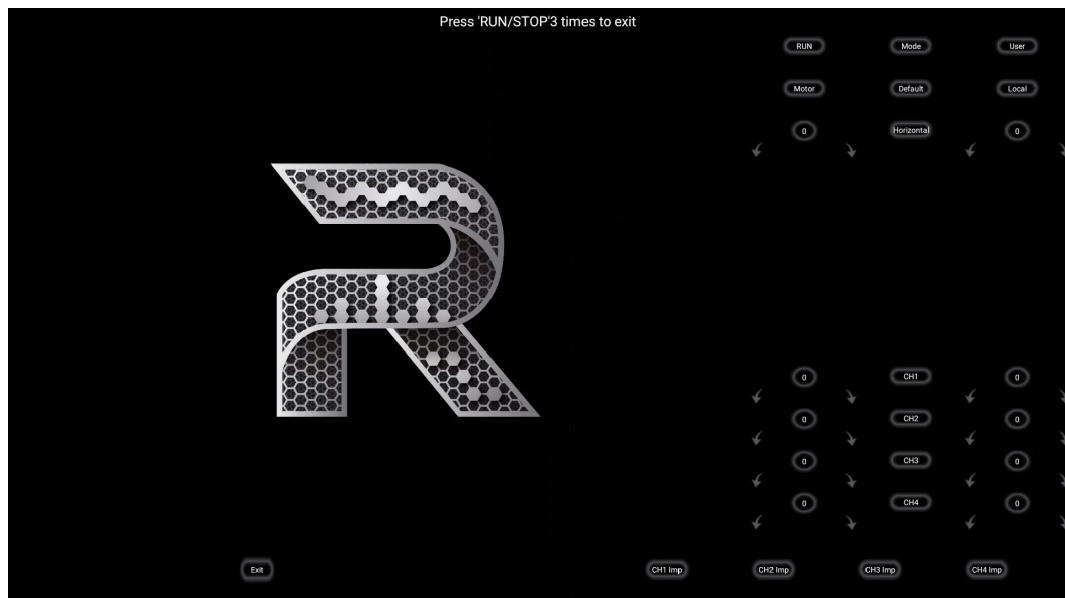

Figure 24.3 Key Test Interface

At this time, you can press the keys on the front panel to check whether the virtual keys are highlighted. If yes, it indicates that the keys work normally; if no, it indicates that there's something wrong with the keys. If the virtual key is not illuminated, the key may fail to work. Click or tap **Exit** to exit the key test interface. Also you can press **RUN/STOP** for three consecutive times to exit the key test interface.

Touch Test

Click or tap **Touch Test** to enter the touch screen test interface, as shown in the figure below.

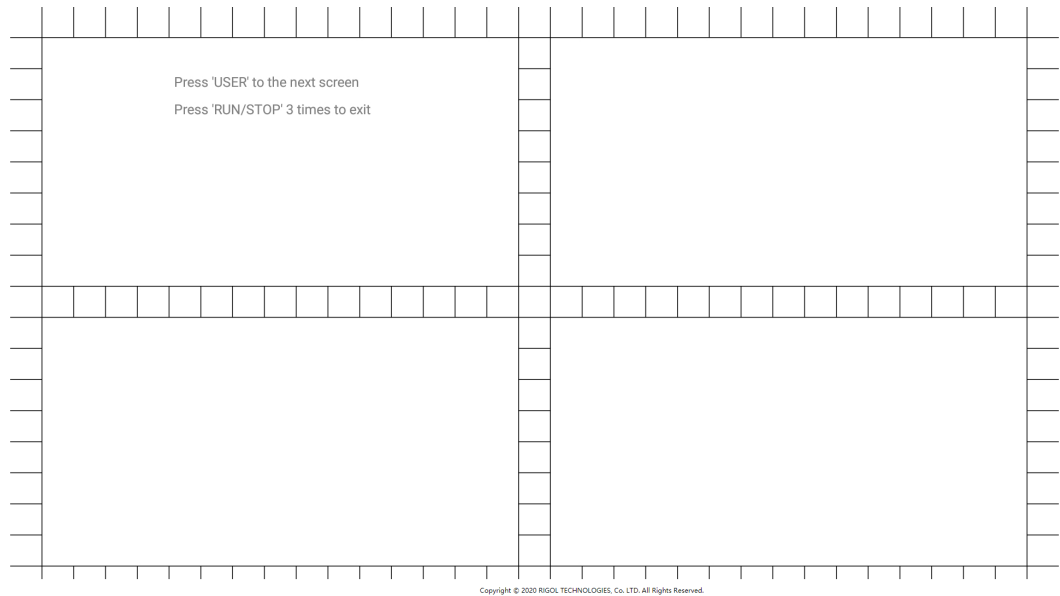

Figure 24.4 Touch Screen Test Interface

Slide with your finger on the screen. If there is a line displaying at the empty area where you slide on the screen and the box that you tap turns out to be filled with green background, it indicates that the touch function of this area is normal. Then press **USER** to switch to the next touch screen test interface, as shown in the figure below.

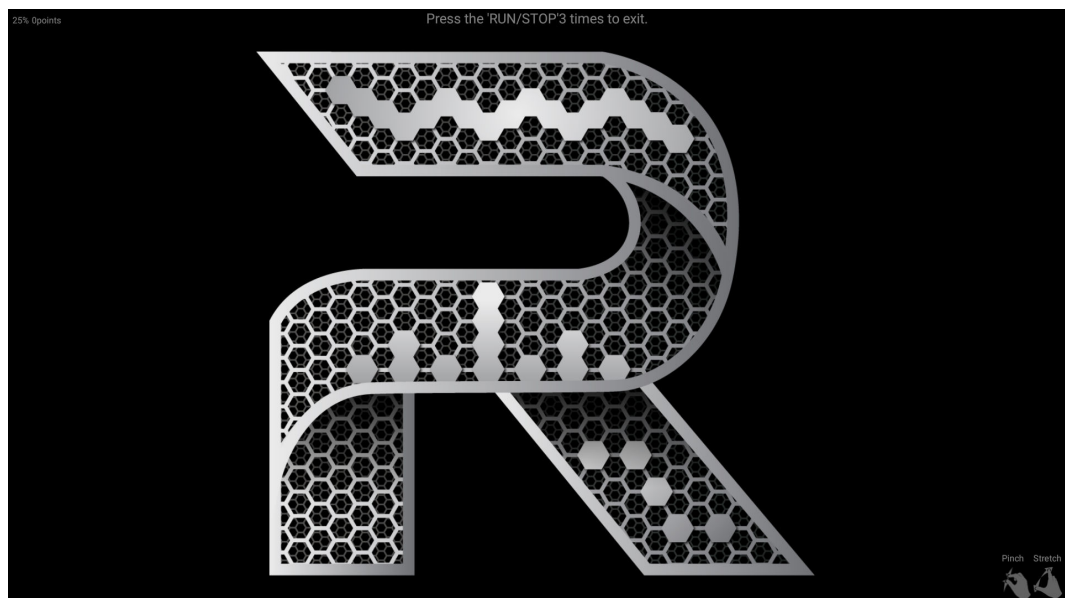

Figure 24.5 Touch-Enabled Gesture Operation Interface

At this time, you can pinch or stretch the icon **R** to zoom out or zoom in the icon to check whether the touch-enabled gestures work normally. Press **RUN/STOP** for three consecutive times to exit the touch screen test interface.

Screen Test

Click or tap **Screen Test** to enter the screen test interface and check whether the defective pixel exists.

There are 15 screen test interfaces. Press **USER** to switch to the next screen test interface. Press **RUN/STOP** for three consecutive times to exit the screen test interface.

Board Test

Click or tap **Board Test**, then the board test interface is displayed. Check whether the status of each module is in good condition.

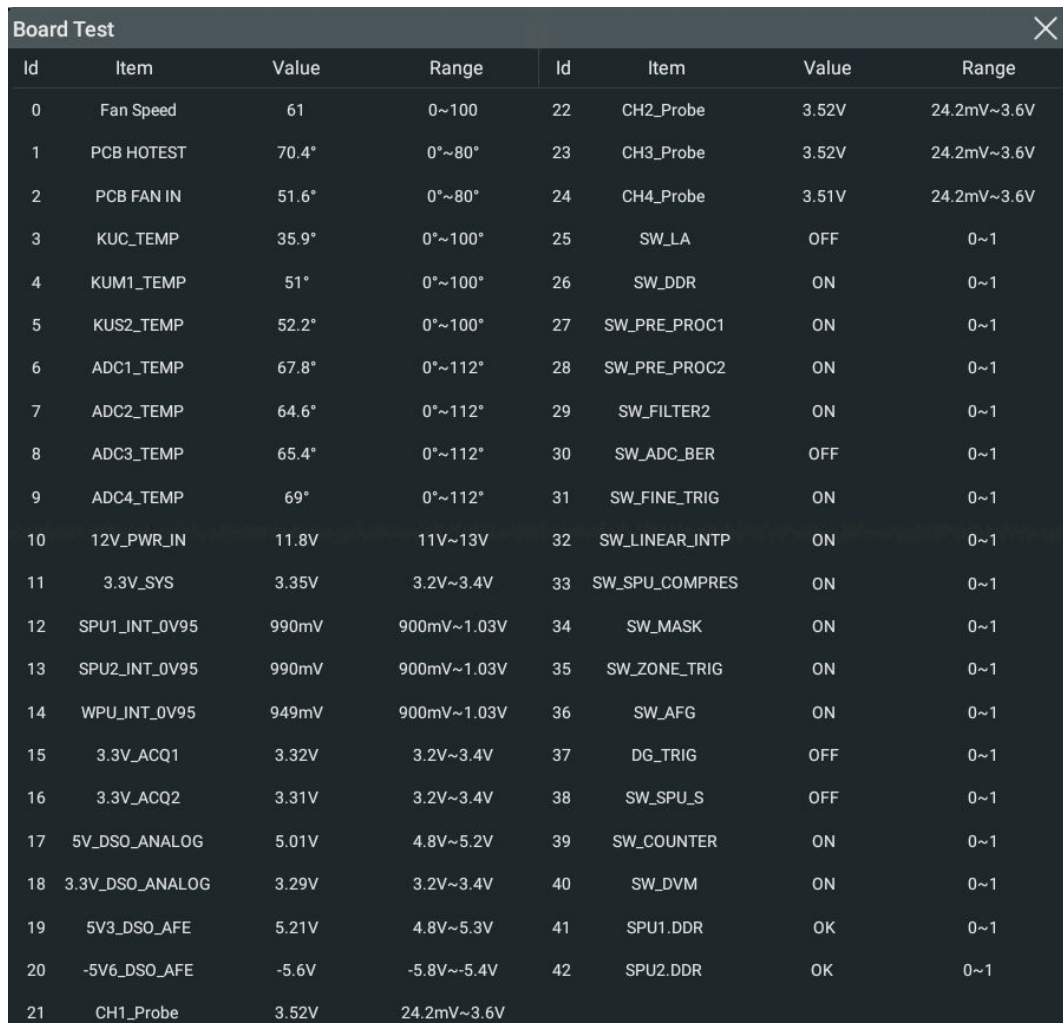

Id	Item	Value	Range	Id	Item	Value	Range
0	Fan Speed	61	0~100	22	CH2_Probe	3.52V	24.2mV~3.6V
1	PCB HOTEST	70.4°	0°~80°	23	CH3_Probe	3.52V	24.2mV~3.6V
2	PCB FAN IN	51.6°	0°~80°	24	CH4_Probe	3.51V	24.2mV~3.6V
3	KUC_TEMP	35.9°	0°~100°	25	SW_LA	OFF	0~1
4	KUM1_TEMP	51°	0°~100°	26	SW_DDR	ON	0~1
5	KUS2_TEMP	52.2°	0°~100°	27	SW_PRE_PROC1	ON	0~1
6	ADC1_TEMP	67.8°	0°~112°	28	SW_PRE_PROC2	ON	0~1
7	ADC2_TEMP	64.6°	0°~112°	29	SW_FILTER2	ON	0~1
8	ADC3_TEMP	65.4°	0°~112°	30	SW_ADC_BER	OFF	0~1
9	ADC4_TEMP	69°	0°~112°	31	SW_FINE_TRIG	ON	0~1
10	12V_PWR_IN	11.8V	11V~13V	32	SW_LINEAR_INTP	ON	0~1
11	3.3V_SYS	3.35V	3.2V~3.4V	33	SW_SPU_COMPRES	ON	0~1
12	SPU1_INT_0V95	990mV	900mV~1.03V	34	SW_MASK	ON	0~1
13	SPU2_INT_0V95	990mV	900mV~1.03V	35	SW_ZONE_TRIG	ON	0~1
14	WPU_INT_0V95	949mV	900mV~1.03V	36	SW_AFG	ON	0~1
15	3.3V_ACQ1	3.32V	3.2V~3.4V	37	DG_TRIG	OFF	0~1
16	3.3V_ACQ2	3.31V	3.2V~3.4V	38	SW_SPU_S	OFF	0~1
17	5V_DSO_ANALOG	5.01V	4.8V~5.2V	39	SW_COUNTER	ON	0~1
18	3.3V_DSO_ANALOG	3.29V	3.2V~3.4V	40	SW_DVM	ON	0~1
19	5V3_DSO_AFE	5.21V	4.8V~5.3V	41	SPU1.DDR	OK	0~1
20	-5V6_DSO_AFE	-5.6V	-5.8V~-5.4V	42	SPU2.DDR	OK	0~1
21	CH1_Probe	3.52V	24.2mV~3.6V				

Figure 24.6 Board Test Interface

24.10 Demonstration Signals

The demonstration signals are standard and predefined signals that are used to demonstrate and test the instrument performance.

In the **Utility** menu, click or tap **Demo Signals** to enter the demonstration signals setting menu.

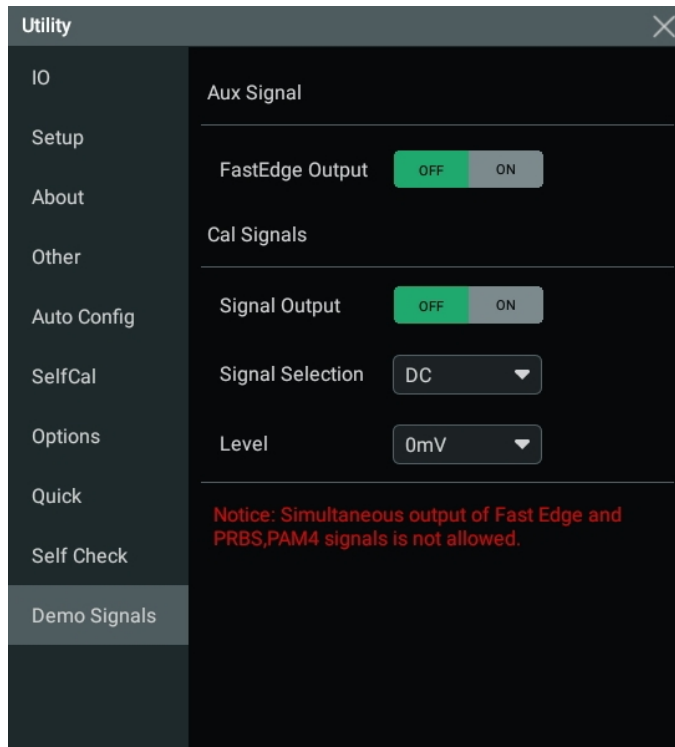

Figure 24.7 Demonstration Signals Menu

Aux Signal

Click or tap the ON/OFF button for the **FastEdge Output** menu item to enable or disable the output of the auxiliary signal. When enabled, a standard fast edge signal is output.

Calibration Signal

- Click or tap the ON/OFF button for the **Signal Output** menu item to enable or disable the output of the calibration signal.
- Click or tap the drop-down button of **Signal Selection** to select the desired calibration signal type. The available calibration signals are DC, PRBS(32), and PAM4.

When you select "DC", click or tap the drop-down button of **Level** to set the DC level. The available DC levels are -2500mV, -1500mV, -600mV, -300mV, -150mV, -60mV, -30mV, 0mV, etc.

Notice

The fast edge signal and the PRBS(32)/PAM4 calibration signals cannot be output at the same time.

25 Remote Control

The following ways of remote control are supported:

- **User-defined Programming**

Users can program and control the instrument by using the SCPI (Standard Commands for Programmable Instruments) commands. For details about the SCPI commands and programming, refer to *Programming Guide* of this product series.

- **PC Software**

Users can use the PC software to send commands to control the instrument remotely. RIGOL Ultra Sigma is recommended. You can download the software from RIGOL official website (<http://www.rigol.com>).

Operation Procedures:

- Set up communication between the instrument and PC.
- Run Ultra Sigma and search for the instrument resource.
- Open the remote command control panel to send commands.

- **Web Control**

This instrument supports Web Control. Connect the instrument to the network, then input the IP address of the instrument into the address bar of the browser of your computer. The web control interface is displayed. Click Web Control to enter the web control page. Then you can view the display of the real-time interface of the instrument. Through the Web Control method, you can migrate the device control to the control terminals (e.g. PC, Mobile, iPad, and other smart terminals) to realize remote control of the instrument.

This instrument can be connected to the PC via the USB, LAN, or GPIB interface to set up communication and realize remote control through the PC. The remote control can be realized by using SCPI (Standard Commands for Programmable Instruments) commands.

This chapter will illustrate how to use the RIGOL Ultra Sigma software to remotely control the instrument via various interfaces. Note: When communicating with the PC via GPIB, the instrument does not support large data transmission operation such as screen shot and waveform reading.



CAUTION

Before connecting the communication cable, please turn off the instrument to avoid causing damage to the communication interfaces.

25.1 Remote Control via USB

1. Connect the device

Use the USB cable to connect the rear-panel USB DEVICE interface of the instrument to the USB HOST interface of the PC.

2. Search for the device resource

Start up Ultra Sigma and the software will automatically search for the resource currently connected to the PC via the USB interface. You can also click **USB-TMC** to search for the resource.

3. View the device resource

The resources found will appear under the "RIGOL Online Resource" directory, and the model number and USB interface information of the instrument will also be displayed.

4. Control the instrument remotely

Right-click the device resource name and select "SCPI Panel Control" to open the remotely command control panel. Then you can send commands and read data through the panel. For details about the SCPI commands and programming, refer to the Programming Guide of this instrument.

25.2 Remote Control via LAN

1. Connect the device

Use the network cable to connect the instrument to your local area network (LAN).

2. Configure network parameters

Configure the network parameters of the instrument in **Utility>IO** menu.

Click or tap the Notification Area at the lower-right corner of the screen, then the **Utility** menu is displayed. Click or tap **IO**, and then click or tap the input field of **GPIB** to input the GPIB address with the pop-up numeric keypad.

3. Search for Search device resource

Start up Ultra Sigma and click **LAN** to open the panel as shown in the figure below. Click **Search** and the software searches for the instrument resources currently connected to the LAN and the resources found are displayed at the right section of the window as shown in the figure below. Click **OK** to add it.

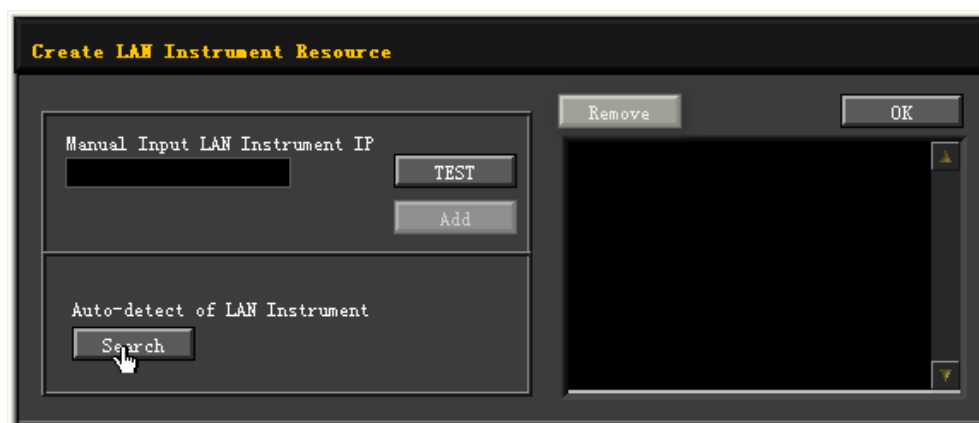

Besides, you can input the IP address of the instrument manually into the text field under "Manual Input LAN Instrument IP", then click **TEST**. If the instrument passes the test, click **Add** to add the instrument to the LAN instrument resource list in the right section; if the instrument fails the test, please check whether the IP address that you input is correct, or use the auto search method to add the instrument resource.

4. View the device resource

The resources found will appear under the "RIGOL Online Resource" directory.

5. Control the instrument remotely

Right-click the device resource name and select "SCPI Panel Control" to open the remotely command control panel. Then you can send commands and read data through the panel.

6. Load LXI webpage

As this instrument conforms to LXI CORE 2011 DEVICE standards, you can load LXI web page through Ultra Sigma (right-click the instrument resource name and select "LXI-Web"). Various important information about the instrument (including the model, manufacturer, serial number, description, MAC address, and IP address) will be displayed on the web page. You can also directly input the IP address of the instrument in the address bar of the PC browser to load the LXI web page.

25.3 Remote Control via GPIB

1. Connect the device

Use the USB-GPIB interface converter to extend the GPIB interface for the instrument, and then use the GPIB cable to connect the instrument to the PC to realize remote control.

2. Install the driver of GPIB card

Correctly install the driver of the GPIB card which has been connected to the PC.

3. Set the GPIB address

Click or tap the Notification Area at the lower-right corner of the screen, then the **Utility** menu is displayed. Click or tap **IO**, and then click or tap the input field of **GPIB** to input the GPIB address with the pop-up numeric keypad.

4. Search for the device resource

Start Ultra Sigma, and then click **GPIB**. A window is displayed as shown in *Figure 25.1*. Click **Search** and the software searches for the instrument resource currently connected to the PC via the GPIB interface. The resource found is displayed at the right side of the window, as shown in *Figure 25.2*. Click **OK** to add it.

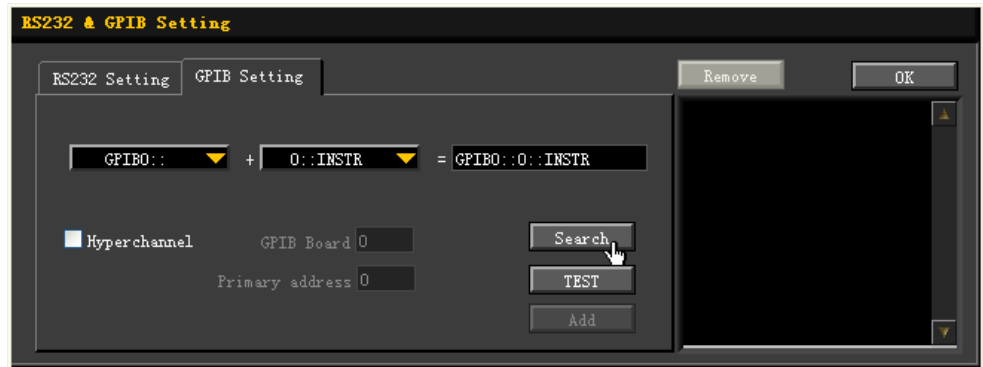

Figure 25.1 Search for the Available Device



Figure 25.2 Confirm the Available Device

5. View the device resource

Click **OK** to go back to the main interface of Ultra Sigma. The searched instrument resource will be displayed under the directory of "RIGOL Online Resource".

6. Control the instrument remotely

Right-click the device resource name. In the displayed menu, select "SCPI Panel Control" to open the programming command control panel. Then you can input commands to send commands and read data.

26 Troubleshooting

1. When I power on the instrument, the instrument stays black and does not display anything.

- a. Check whether the power is correctly connected.
- b. Check whether the power key is really pressed.
- c. Check whether the fuse is blown. If you need to replace the fuse, use only the specified fuse that conforms to the product.
- d. Restart the instrument after finishing the above inspections.
- e. If the problem still persists, please contact RIGOL.

2. No waveform of the signal is displayed on the screen.

- a. Check whether the probe is properly connected to the item under test.
- b. Check whether there are signals generated from the item to be tested (you can connect the probe compensation signal to the channel to locate the problem, and then determine whether the channel or the item to be tested has a problem).
- c. Resample the signal.
- d. If the problem still persists, please contact RIGOL.

3. The USB storage device cannot be recognized.

- a. Check whether the USB storage device can work normally when connected to other instruments or PC.
- b. Make sure that the USB storage device is FAT32 format and flash type. The instrument doesn't support hardware USB storage device.
- c. After restarting the instrument, insert the USB storage device again to check whether it can work normally.
- d. If the USB storage device still cannot work normally, please contact RIGOL.

4. How do you set the amplitude of the waveform in dBm?

- a. Select the desired channel.
- b. In the channel setting interface, check whether HighZ under **OutputSet** is set to "On". If yes, you cannot set the amplitude of the waveform in dBm at this time. Select "Off" to disable the HighZ, and use the numeric keypad, the arrow keys, and knob to set it to a proper value.

- c. Select the desired waveform, tap the Amplitude menu label, and then input the desired value by using the numeric keypad. Then select the unit "dBm" from the pop-up menu.

5. The touch functions cannot be used normally.

- a. Check whether you have locked the touch screen. If yes, unlock the touch screen.
- b. Check whether the screen or your finger is stained with oil or sweat. If yes, please clean the screen or dry your hands.
- c. Check whether there is a strong magnetic field around the instrument. If the instrument is close to the strong magnetic field (e.g. a magnet), please move the instrument away from the magnet field.
- d. If the problem still persists, please contact RIGOL.

27 Appendix

27.1 Appendix A: Options and Accessories

Order Information	Order No.
Model	
6 GHz, 40 GSa/s, 2-CH	DS80602
6 GHz, 40 GSa/s, 4-CH	DS80604
8 GHz, 40 GSa/s, 2-CH	DS80802
8 GHz, 40 GSa/s, 4-CH	DS80804
10 GHz, 40 GSa/s, 2-CH	DS81002
10 GHz, 40 GSa/s, 4-CH	DS81004
13 GHz, 40 GSa/s, 2-CH	DS81302
13 GHz, 40 GSa/s, 4-CH	DS81304
Standard Accessories	
Power Cord Conforming to the Standard of the Destination Country	— —
USB Cable x1	— —
Adapter Options	
BNC Adapter, 3.5 mm to BNC (50 Ω)	BNC Adapter Input 50Ω
High-impedance Adapter, 3.5 mm to BNC (1 MΩ)	High Impedance Adapter
Upgrade Option	
2 Gpts Memory Depth Upgrade Option	DS80000-RLU-20
4 Gpts Memory Depth Upgrade Option	DS80000-RLU-40
Measurement and Analysis Option	
Advanced Eye Diagram and Jitter Analysis Option	DS80000-JITTA
Pre-compliance Test Option	
100M/1000M Ethernet Compliance Test	DS80000-ENETC
USB2.0 Compliance Test	DS80000-USBC
Serial Protocol Decoding Options	
Embedded Serial Bus Trigger and Decoding (RS232/UART, I2C, and SPI)	DS80000-EMBDA
Auto Serial Bus Trigger and Decoding (CAN, CAN-FD, LIN, FlexRay)	DS80000-AUTOA
Audio Serial Bus Trigger and Decoding (I2S)	DS80000-AUDIOA
MIL-STD-1553 Serial Bus Triggers and Decodings	DS80000-AEROA

**NOTE**

For all the mainframes, accessories, and options, please contact the local office of RIGOL.

27.2 Appendix B: Warranty

RIGOL TECHNOLOGIES CO., LTD. (hereinafter referred to as RIGOL) warrants that the product mainframe and product accessories will be free from defects in materials and workmanship within the warranty period. If a product proves defective within the warranty period, RIGOL guarantees free replacement or repair for the defective product.

To get repair service, please contact your nearest RIGOL sales or service office.

There is no other warranty, expressed or implied, except such as is expressly set forth herein or other applicable warranty card. There is no implied warranty of merchantability or fitness for a particular purpose. Under no circumstances shall RIGOL be liable for any consequential, indirect, ensuing, or special damages for any breach of warranty in any case.

Boost Smart World and Technology Innovation

Industrial Intelligent
Manufacturing



Semiconductors

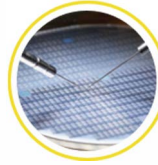

Education &
Research

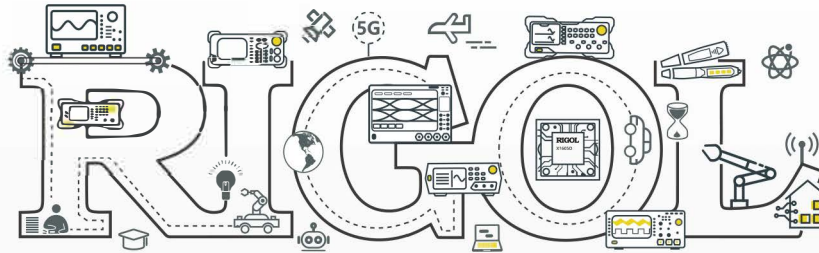

Communication

System Integration

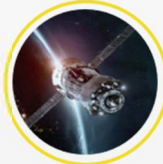

New Energy



- 5G Cellular-5G/WIFI
- UWB/RFID/ ZIGBEE
- Digital Bus/Ethernet
- Optical Communication

- Digital/Analog/RF Chip
- Memory and MCU Chip
- Third-Generation Semiconductor
- Solar Photovoltaic Cells

- New Energy Automobile
- PV/Inverter
- Power Test
- Automotive Electronics

*Provide Testing and Measuring Products
and Solutions for Industry Customers*

Distribution in the UK & Ireland



**Characterisation,
Measurement &
Analysis**

Lambda Photometrics Limited
Lambda House Batford Mill
Harpenden Herts AL5 5BZ
United Kingdom
E: info@lambdaphoto.co.uk
W: www.lambdaphoto.co.uk
T: +44 (0)1582 764334
F: +44 (0)1582 712084