



RIGOL USB 2.0 Compliance Test User Manual

Distribution in the UK & Ireland



Lambda Photometrics Limited
Lambda House Batford Mill
Harpenden Herts AL5 5BZ
United Kingdom
E: info@lambdaphoto.co.uk
W: www.lambdaphoto.co.uk
T: +44 (0)1582 764334
F: +44 (0)1582 712084



Table of Contents

1	Document Overview	1
2	Fixture Layout	2
2.1	High-Speed Device Electrical Test Fixture	2
2.2	High-Speed Device Signal Quality Test Fixture	3
2.3	High-Speed Host Signal Quality Test Fixture	4
2.4	USB-A High-Speed Host Signal Quality Test Fixture	4
3	High-Speed Signal Test Items	6
4	Preparation Before Test	7
4.1	Oscilloscope	7
4.2	Probe	7
4.3	Driver Installation	8
5	Fixture Application	10
5.1	High-Speed Device Signal Quality Compliance Test	10
5.1.1	Test Connection Diagram	10
5.1.2	Test Steps	11
5.2	High-Speed Host Signal Quality Compliance Test	15
5.2.1	Test Connection Diagram	16
5.2.2	Test Steps	17
5.3	Hub Upstream High-Speed Signal Quality Compliance Test	21
5.3.1	Test Connection Diagram	21
5.3.2	Test Steps	22
5.4	Hub Downstream High-Speed Signal Quality Compliance Test	26
5.4.1	Test Connection Diagram	27
5.4.2	Test Steps	28

Illustration Directory

- Figure 5.1 High-Speed Device Signal Quality Compliance Test (Differential Probe) Connection Diagram
- Figure 5.2 High-Speed Device Signal Quality Compliance Test (SMA Cable) Connection Diagram
- Figure 5.3 USB2.0 Test Model
- Figure 5.4 High-Speed Host Signal Quality Compliance Test (Differential Probe) Connection Diagram
- Figure 5.5 High-Speed Host Signal Quality Compliance Test (SMA Cable) Connection Diagram
- Figure 5.6 USB2.0 Test Model
- Figure 5.7 Hub Upstream High-Speed Signal Quality Compliance Test (Differential Probe) Connection Diagram
- Figure 5.8 Hub Upstream High-Speed Signal Quality Compliance Test (SMA Cable) Connection Diagram
- Figure 5.9 USB2.0 Test Model
- Figure 5.10 Hub Downstream High-Speed Signal Quality Compliance Test (Differential Probe) Connection Diagram
- Figure 5.11 Hub Downstream High-Speed Signal Quality Compliance Test (SMA Cable) Connection Diagram
- Figure 5.12 USB2.0 Test Model

Table Directory

- Table 2.1 HS Device Electrical Test Fixture Layout Description
 - Table 2.2 HS Device SQ Test Fixture Layout Description
 - Table 2.3 HS Host SQ Test Fixture Layout Description
 - Table 2.4 USB-A HS Host SQ Fixture Layout Description
 - Table 5.1 Tool List: High-Speed Device Signal Quality Compliance Test
 - Table 5.2 Tool List: High-Speed Host Signal Quality Compliance Test
 - Table 5.3 Tool List: Hub Upstream High-Speed Signal Quality Compliance Test
 - Table 5.4 Tool List: Hub Downstream High-Speed Signal Quality Compliance Test
 - Table 6.1 Fixture Specifications
 - Table 6.2 Ordering Information
-

1 Document Overview

This manual describes the layout and application of 4 types of fixtures. These fixtures are used for USB 2.0 signal integrity compliance testing.

The 4 types of fixtures are:

- High-speed device electrical test fixture
- High-speed device signal quality test fixture
- High-speed host signal quality test fixture
- USB-A high-speed host signal quality test fixture

Fixture application scenarios:

- High-speed device signal quality compliance test
- High-speed host signal quality compliance test
- Hub upstream high-speed signal quality compliance test
- Hub downstream high-speed signal quality compliance test

1. Buttons

Front panel buttons of the oscilloscope are represented by  , e.g., indicating the "Default" button.

2. Menus

Menu options are represented by "Menu Text (bold) + Character Shading," such as

Device Under Test which means pressing on the "Device Under Test" option on the instrument's current operating interface to enter the "Device Under Test" function configuration menu.

3. Operation Steps

An arrow ">" indicates the next operation, such as  > Test Item which means pressing a function key and then pressing the test item.

2 Fixture Layout

2.1 High-Speed Device Electrical Test Fixture

The layout of the High-Speed Device Electrical Test Fixture is shown in the figure below:

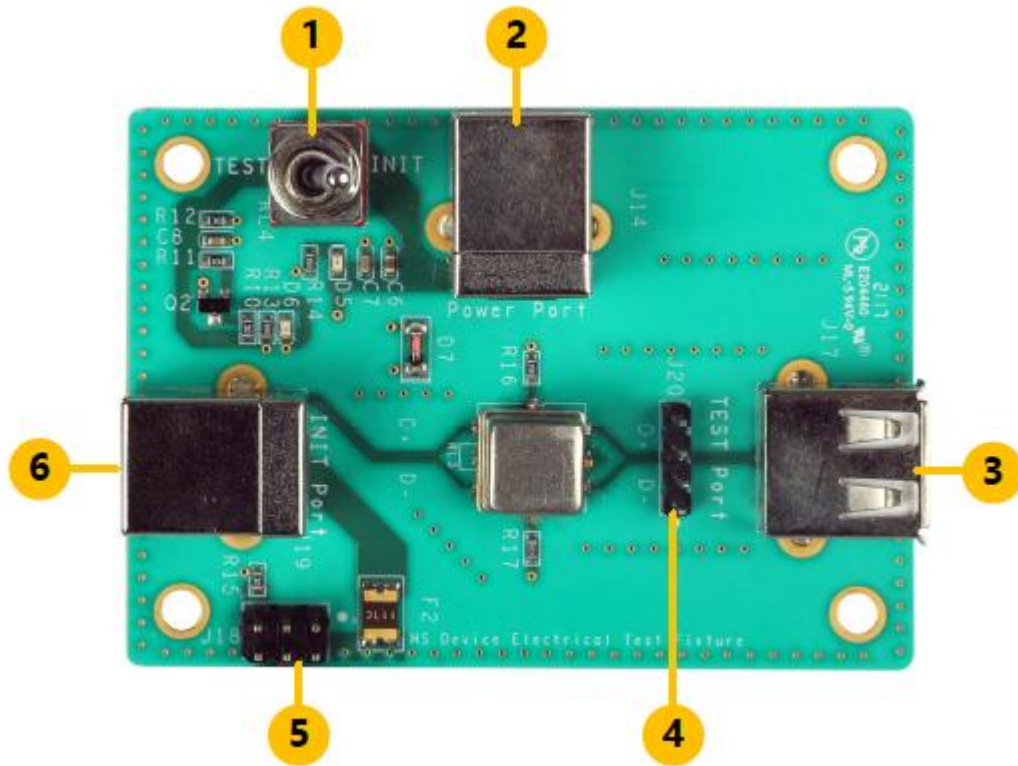

Table 2.1 HS Device Electrical Test Fixture Layout Description

Number	Description
1	Test switch, toggle to switch relay direction
2	USB-B female connector, power socket
3	USB-A female connector, connect to Device
4	1x4 Pin gold pin header, the middle two pins are differential probe sockets, the outer two are ground
5	2x3 Pin gold pin header, pins 4/6 are 5V for the Device, pin 5 is 5V for the USB-B power socket (a jumper cap is needed to connect pins 5 and 6)
6	USB-B female connector, connect to a machine with USB test software

2.2 High-Speed Device Signal Quality Test Fixture

The layout of the High-Speed Device SQ Test Fixture is shown in the figure below:

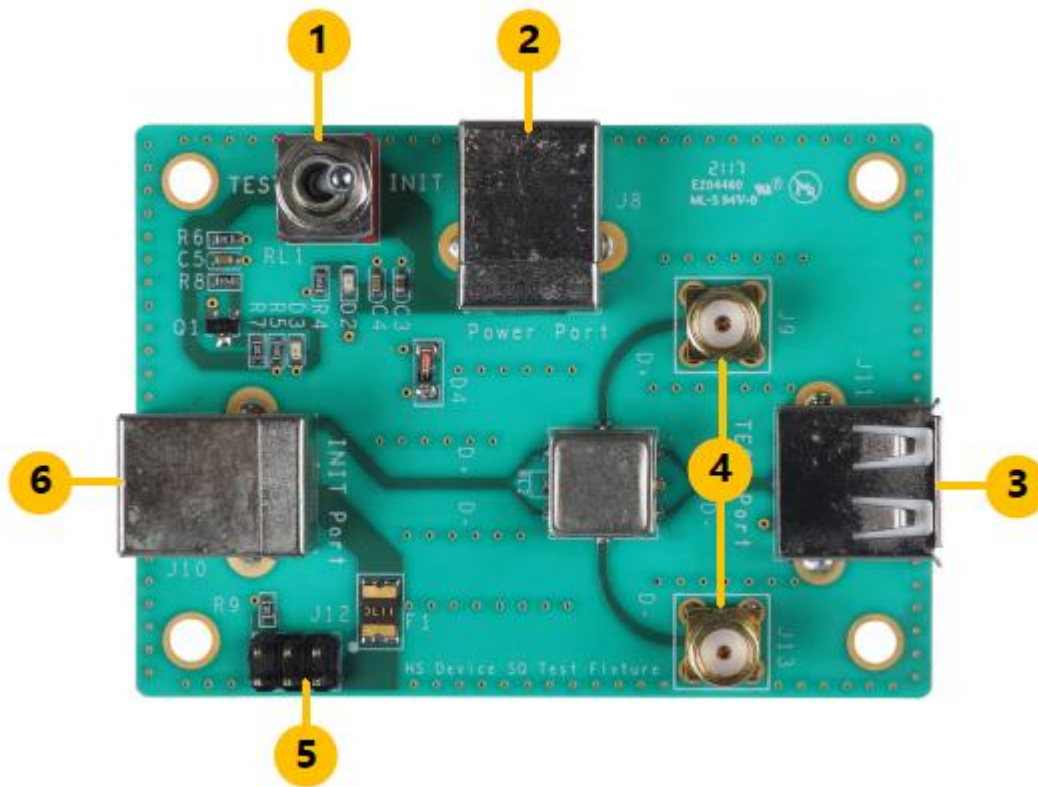

Table 2.2 HS Device SQ Test Fixture Layout Description

Number	Description
1	Test switch, toggle to switch relay direction
2	USB-B female connector, power socket
3	USB-A female connector, connect to Device
4	SMA socket
5	2×3 Pin gold pin header, pins 4/6 are 5V for the Device, pin 5 is 5V for the USB-B power socket (a jumper cap is needed to connect pins 5 and 6)
6	USB-B female connector, connect to a machine with USB test software

2.3 High-Speed Host Signal Quality Test Fixture

The layout of the High-Speed Host SQ Test Fixture is shown in the figure below:

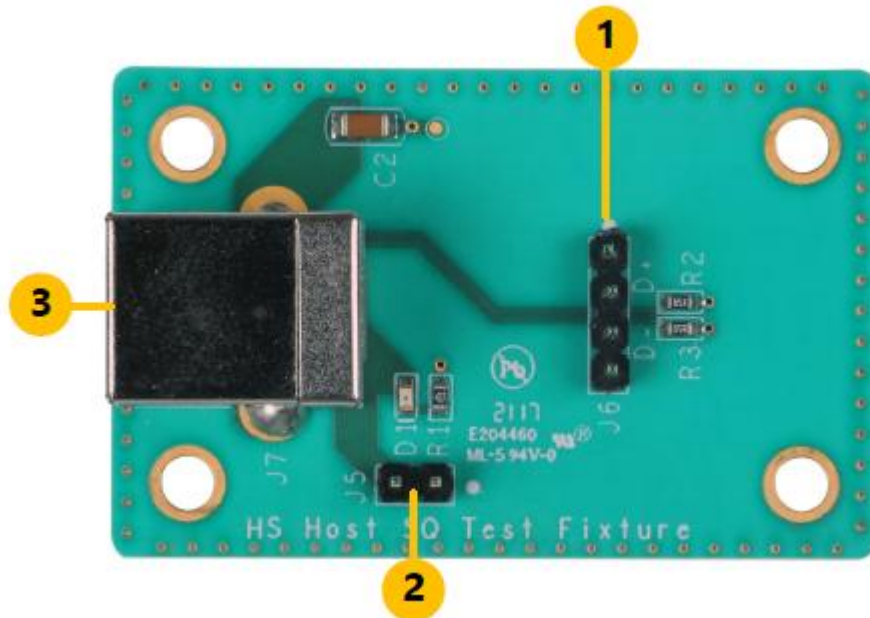

Table 2.3 HS Host SQ Test Fixture Layout Description

Number	Description
1	1×4 Pin gold pin header, the middle two pins are differential probe sockets, the outer two are ground
2	1×2 Pin gold pin header (voltage test point)
3	USB-B female connector, connect to a machine with USB test software

2.4 USB-A High-Speed Host Signal Quality Test Fixture

The layout of the USB-A High-Speed Host Signal Quality Test Fixture is shown in the figure below:

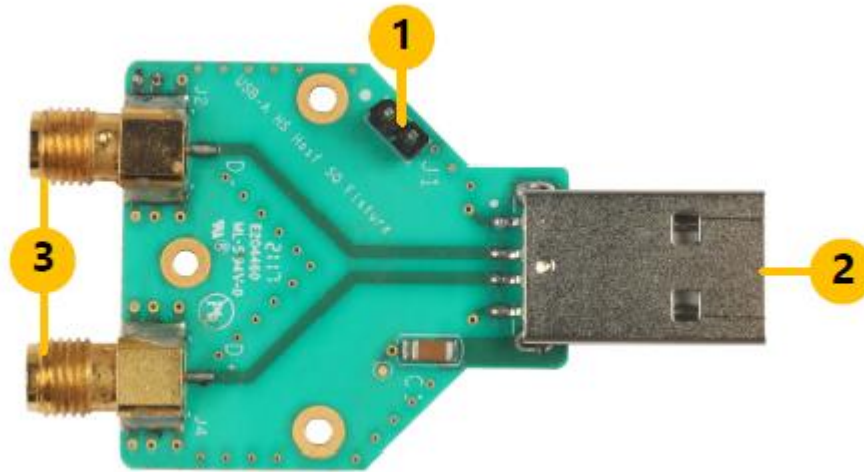

Table 2.4 USB-A HS Host SQ Fixture Layout Description

Number	Description
1	1×2 Pin gold pin header (voltage test point)
2	USB-A male connector, connect to a machine with USB test software (host)
3	SMA socket

3 High-Speed Signal Test Items

Test Item	Minimum Value	Maximum Value
Synchronization Field	32 bit	32 bit
Signal Rate	479.76 Mb/s	480.24 Mb/s
End Field	39.5 bit (7.5 bit) [1]	40.5 bit (8.5 bit) [1]
Monotonicity	0	50 mV
Edge Rise/Fall Time	500 ps	NA
Edge Rise/Fall Rate	NA	1600 V/us
JK Pair Jitter	-100 ps	100 ps
KJ Pair Jitter	-100 ps	100 ps
Consecutive Jitter	-100 ps	100 ps
Eye Diagram Template Measurement	0	0

Note

[1]: The value in parentheses for the End Field refers to non-start frame data.

4 Preparation Before Test

Before conducting the test, users need to make the following preparations:

- Prepare an oscilloscope that supports USB 2.0 analysis functions.
- Prepare a computer with a USB 2.0 interface. Install the "High-Speed Electrical Test Tool Kit Software" (XHCI-HSETT) on the computer. The software download address is:

<https://www.usb.org/document-library/xhsett-x64>, and the software installation package name is XHSETT 2.2.0.0 Installer-x64 Release.exe.

- Prepare the device under test.
- Prepare other necessary test tools: fixtures, jumper caps (for shorting gold pin headers), probes, and SMA cables, etc.

4.1 Oscilloscope

Users need to prepare an oscilloscope that supports USB2.0 analysis functions. According to USB-IF association requirements, the oscilloscope needs to have a bandwidth of 2.0 GHz or more and a sampling rate of 5 GSa/s or more. For the test oscilloscope, ensure that the following operations have been performed:

- Warm up the oscilloscope for 30 minutes before use.
- Perform the self-calibration procedure when the ambient temperature changes by 5°C or more (refer to the oscilloscope's "User Manual" for detailed procedures).
- Perform "Function Check" and "Probe Compensation" operations (refer to the oscilloscope's "User Manual" for detailed procedures).

4.2 Probes

Differential probes are used for high-speed signal quality compliance testing, including:

- High-speed device signal quality compliance test
- High-speed host signal quality compliance test
- Hub upstream high-speed signal quality compliance test
- Hub downstream high-speed signal quality compliance test

Differential probes need a bandwidth of 2.0 GHz or more, and RIGOL PVA8350, PVA8700 differential probes are recommended.

4.3 Driver Installation

After installing the "High-Speed Electrical Test Tool Kit Software", if the software does not automatically update the driver, the user needs to update the "xHCI Compliance Test Host Controller" driver in the computer's device manager according to the following steps.

1. Open the computer's device manager, find "Universal Serial Bus controllers", right-press "USB eXtensible Host Controller", and select "Update driver" in the pop-up dialog box, as shown in the figures below.

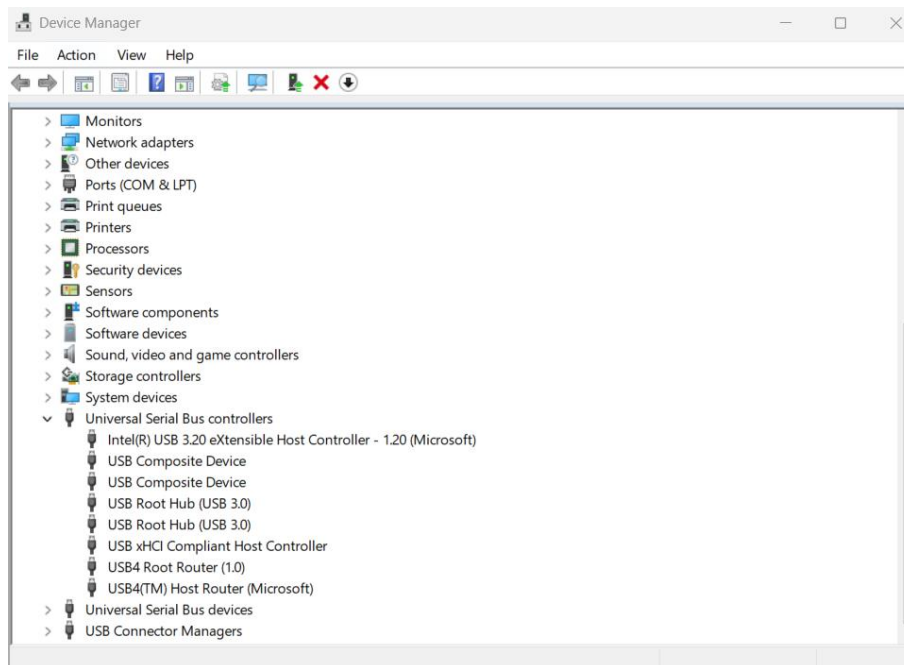

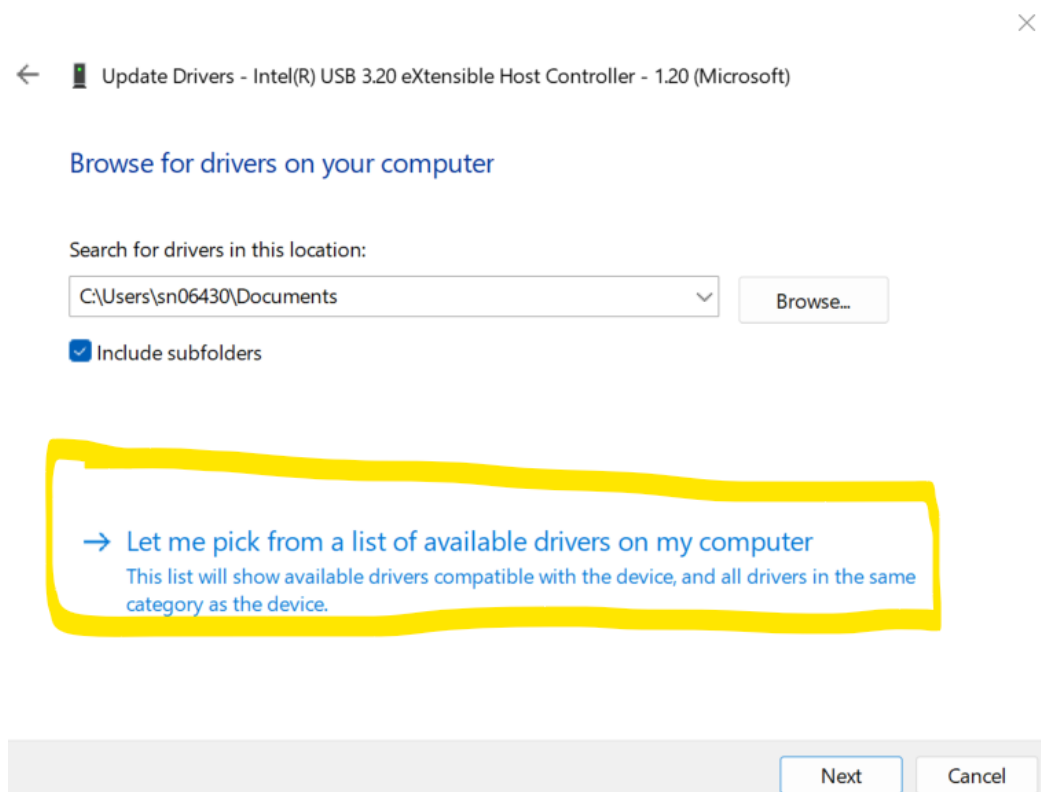
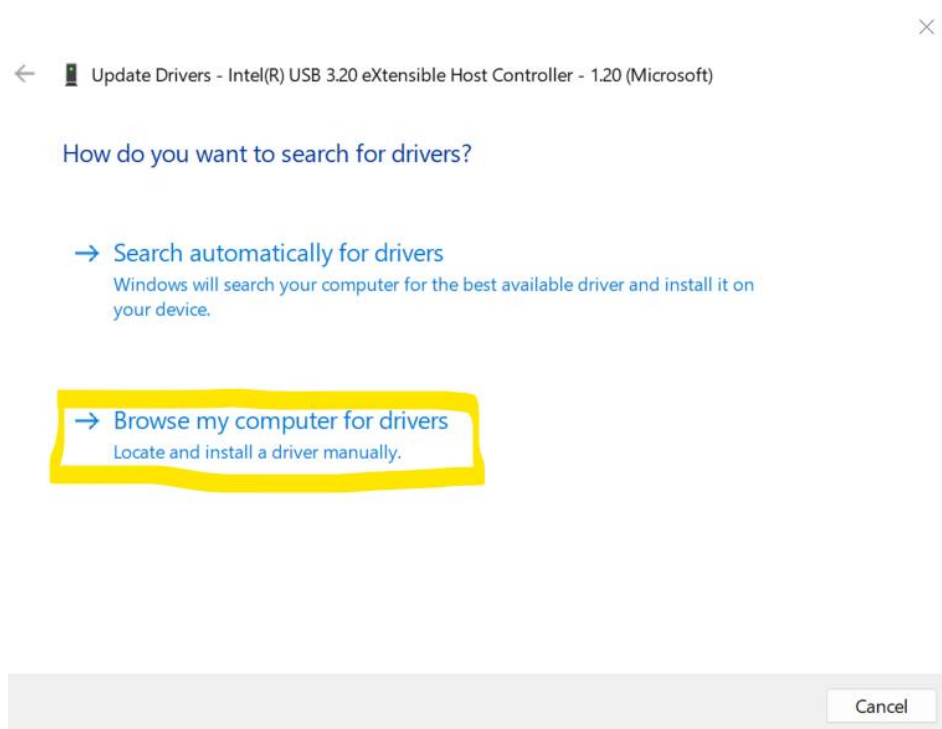

2. In the update driver dialog box, select "Browse my computer for driver software", then select "Let me pick from a list of available drivers on my computer", and select "xHCI Compliance Test Host Controller" from the list below to complete the driver switching.

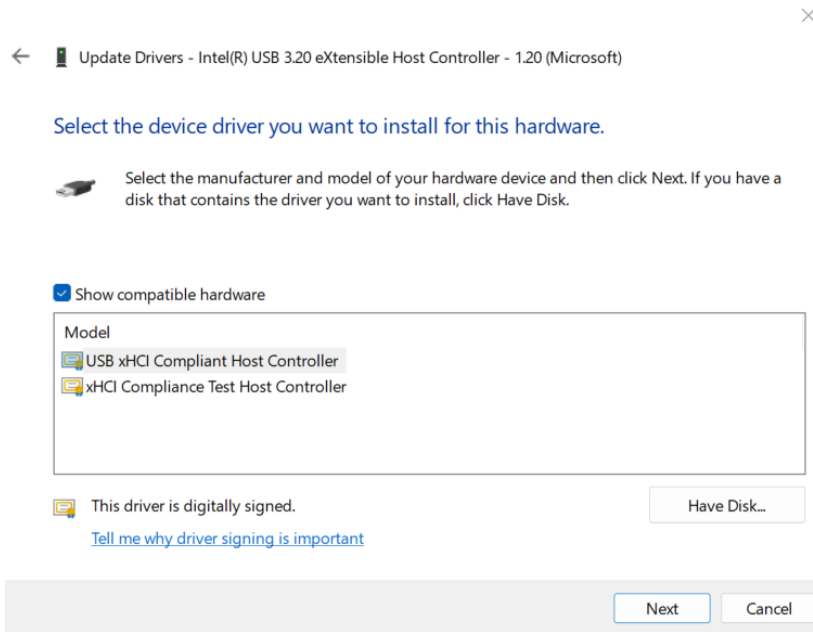

Note:

If you can't find the program on the desktop, you can locate it by going to the **Start** menu, as shown below.

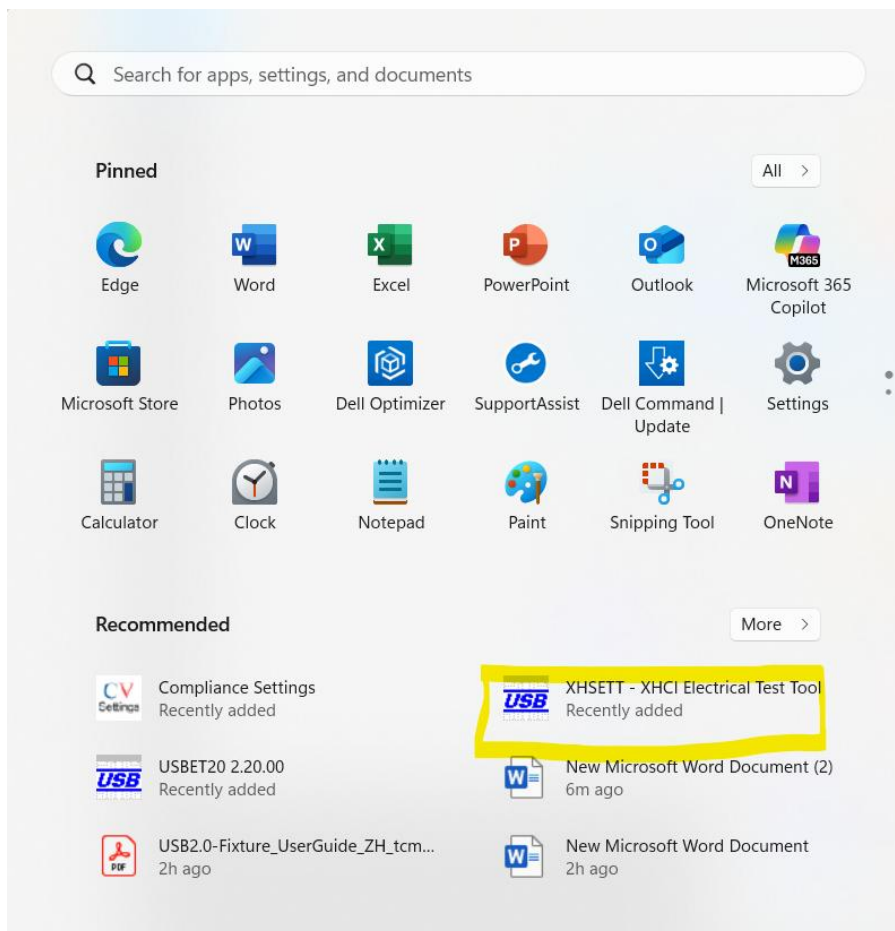



Tip

After switching the serial port driver, the functions of all USB interfaces on the host (i.e., keyboard, mouse, and other USB devices may not be usable) may become invalid. At this time, the host can only be remotely controlled by another computer or by touchpad (do not restart the computer during the test).

5 Fixture Application

5.1 High-Speed Device Signal Quality Compliance Test

5.1.1 Test Connection Diagram

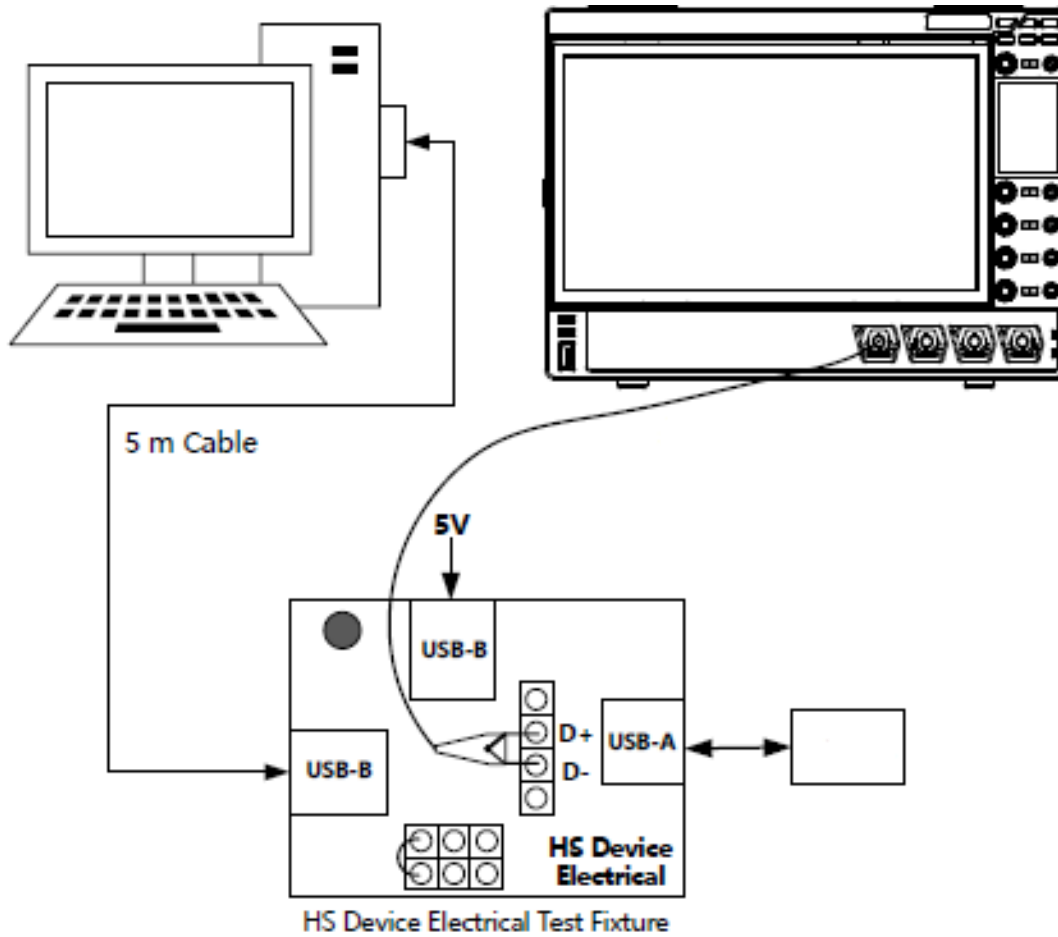

Figure 5.1 High-Speed Device Signal Quality Compliance Test (Differential Probe) Connection Diagram

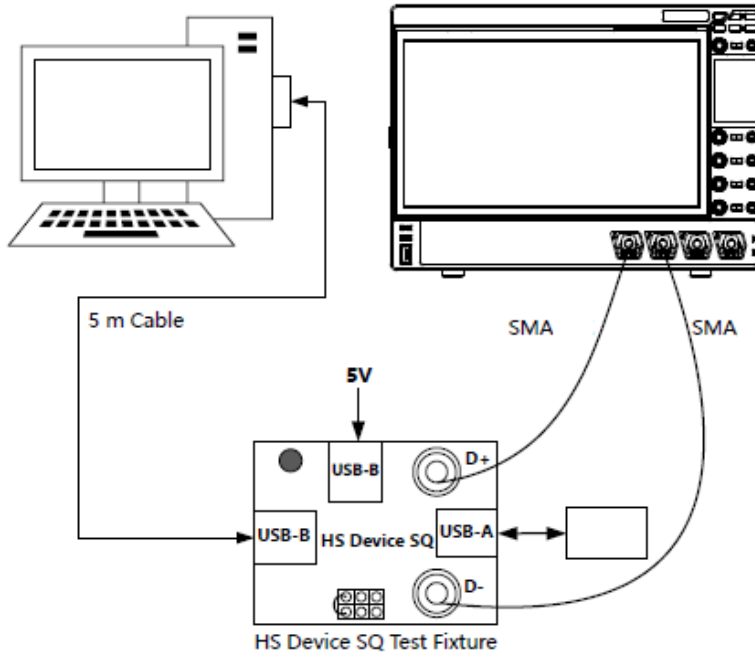

Figure 5.2 High-Speed Device Signal Quality Compliance Test (SMA Cable) Connection Diagram

Table 5.1 Tool List: High-Speed Device Signal Quality Compliance Test

Equipment	Description
Test Fixture	HS Device Electrical Test Fixture (Differential Probe) HS Device SQ Test Fixture (SMA Cable)
Oscilloscope	2.0 GHz or higher bandwidth, 5 GSa/s or higher sample rate, RIGOL DS70000 series oscilloscope recommended
High-speed Device Under Test	—
Test Host	Has a USB 2.0 interface
USB-A male to USB-B male cable	2 cables, connect fixture to host, and fixture to power respectively
Differential probe or SMA cable	Connect fixture to oscilloscope
Jumper cap	Used to short pins 5 and 6 of the gold pin header

5.1.2 Test Steps

Before starting the test, please prepare the necessary tools.

Tip

Before testing, please keep the fixture's Test switch OFF.

1. Connect the test setup and equipment according to the method in the test connection diagram. You can choose to use "differential probe" or "SMA cable" for device testing.
2. Switch or install the driver according to the "Driver Installation" section.
3. After successful installation, open the "XHCI HSETT" software, select the correct controller, then select "Device" as the high-speed test object, and then press TEST to start the test.

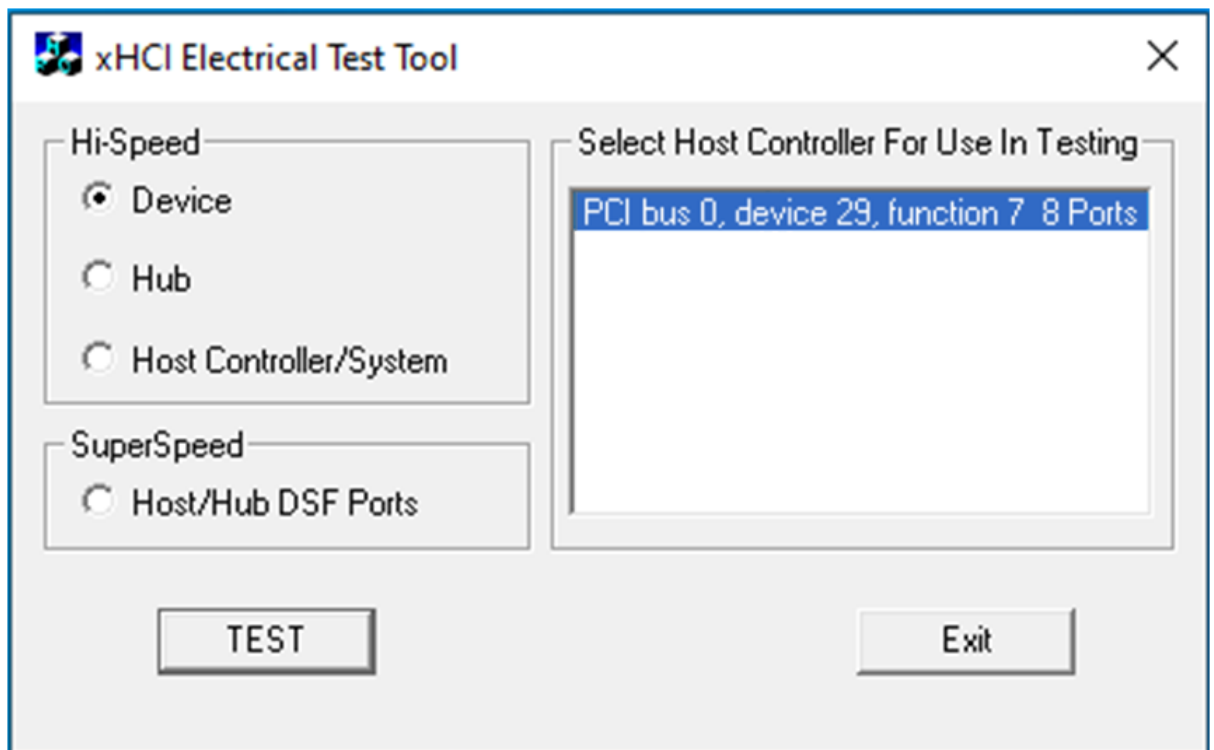

4. Press the Enumerate Bus button to refresh the host port, select "TEST_PACKET" in "Device Command", press EXECUTE after selecting, if the Status Window prompts "Operation Successful", it means the selected signal output is successful.

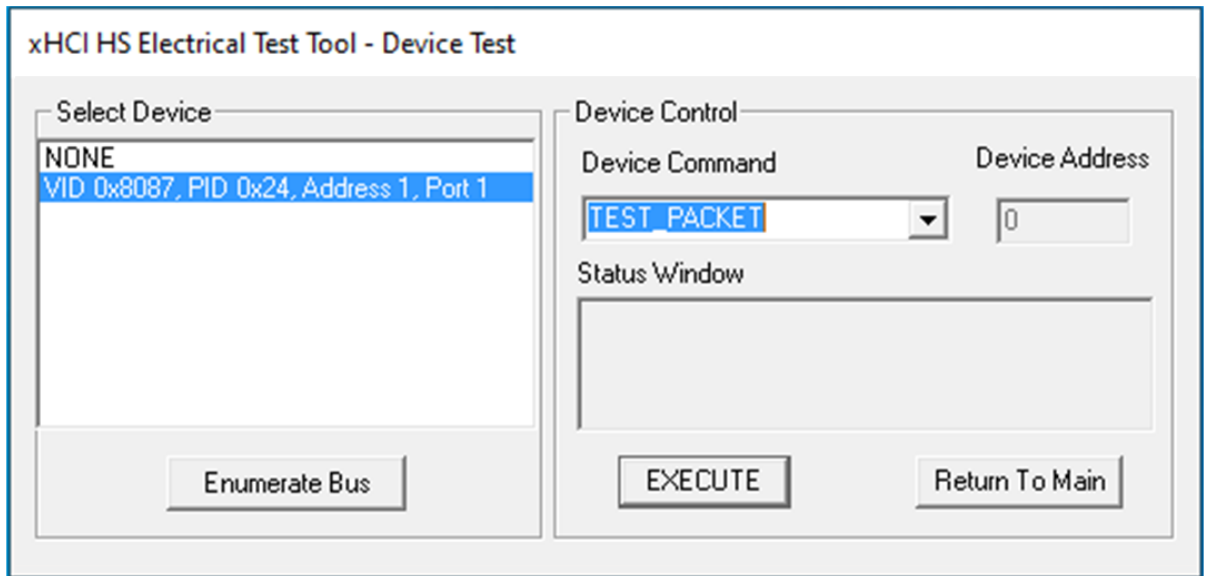

5. Finally, turn on the Test switch of the fixture. At this time, both signal lights of the fixture will light up, and the signal will start to transmit. You can obtain the signal through the oscilloscope and then start the compliance analysis.

6. Start the test (taking the DS70000 series oscilloscope as an example):
 - a. Open the "USB2.0 Compliance Analysis Interface".



- b. In the **Device Under Test** interface (as shown in the figure below), select "Device", "High Speed" respectively, and select "Endpoint" according to the actual situation.

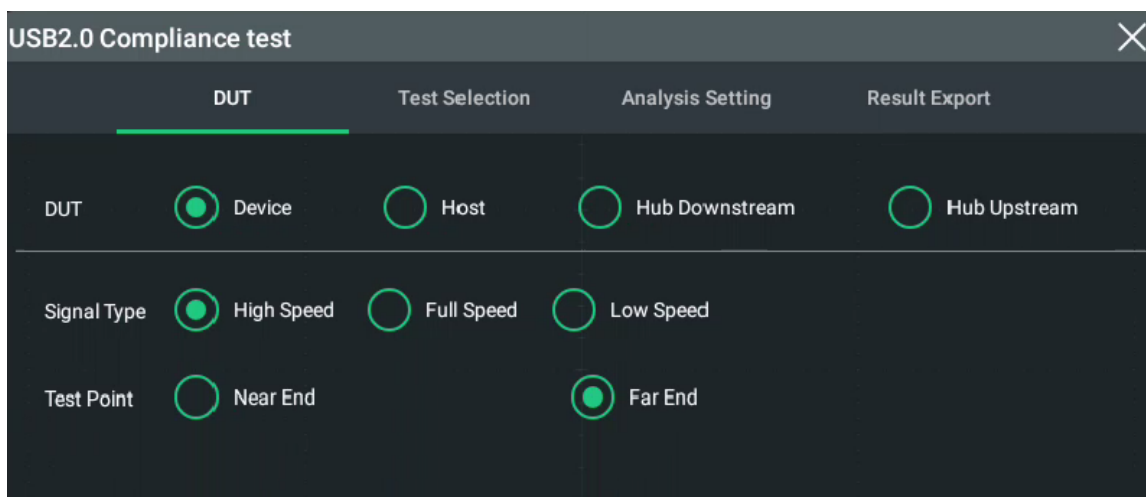

Note

When the signal type is "High Speed", users can choose "Near End" or "Far End" according to the test scenario. The selection of "Near End" and "Far End" depends on the test port situation of the device under test, as shown in the figure below.

- When there is no USB Cable between the device under test and the host, and the test point is at TP3, according to the USB2.0 protocol content, the eye diagram template selects Template1, and at this time, the user selects "Near End".
- When there is a USB Cable between the device under test and the host, and the test point is at TP2, according to the USB2.0 protocol content, the eye diagram template selects Template2, and at this time, the user selects "Far End".

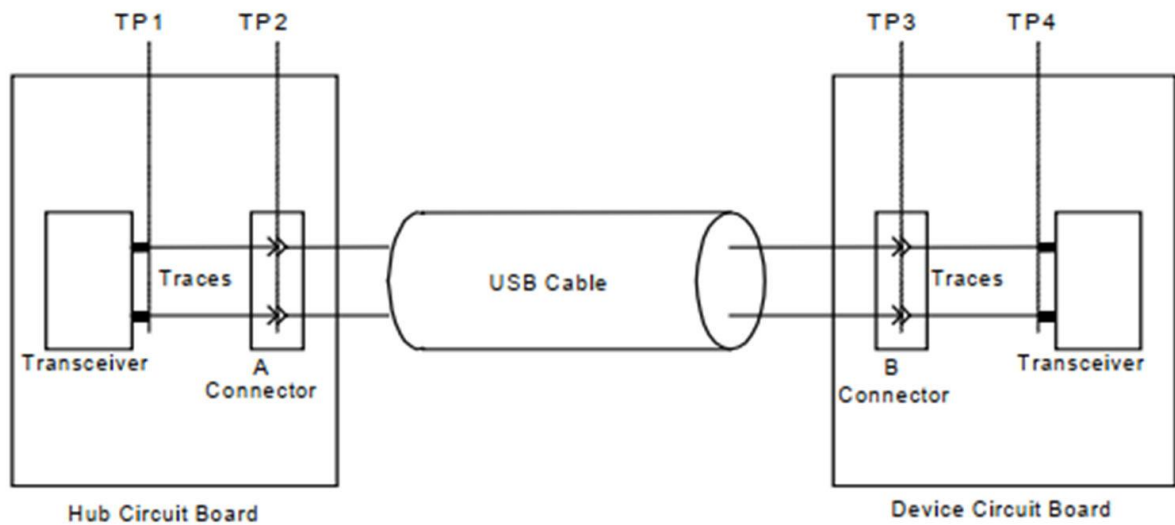
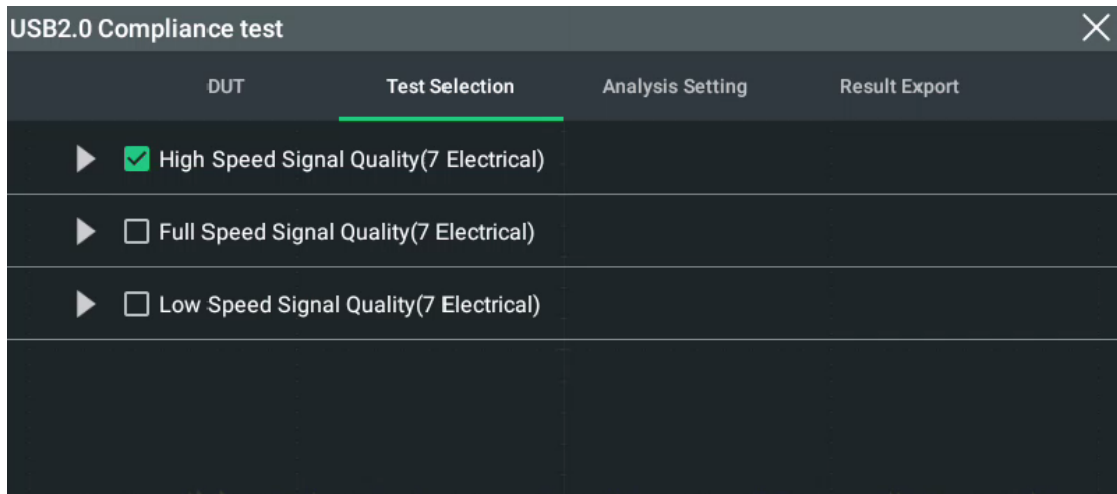
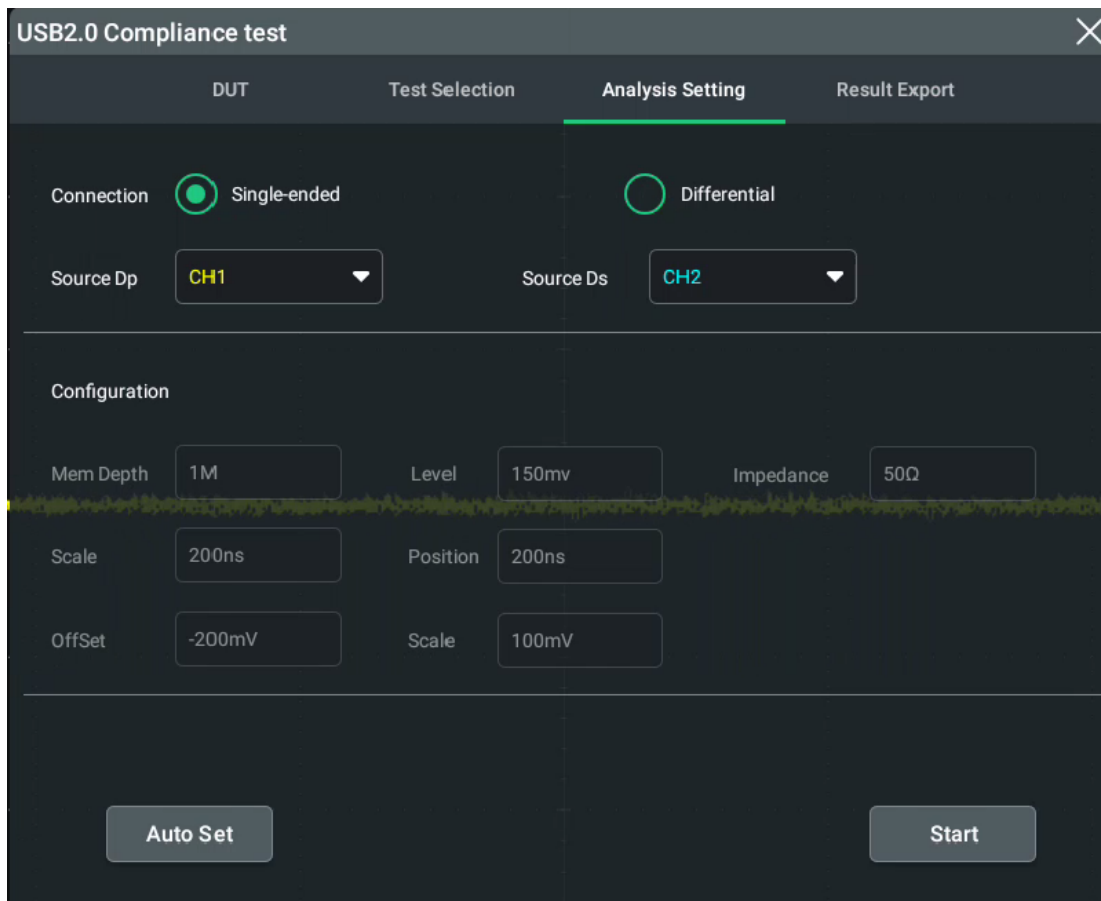

Figure 5.3 USB2.0 Test Model

c. Press to open the **Test Items** interface (as shown in the figure below), and select "High Speed Signal Quality (7 Electrical)".



d. Press to open the **Analysis Settings** interface (as shown in the figure below), and select "SMA Cable Connection" (Single-ended) or "Differential Probe" in the "Test Connection" item according to the actual situation; and select the test "Signal Source".



Press **Auto Set**, the oscilloscope will automatically set the configuration information, and finally press **Start Measurement** to perform USB2.0 signal quality compliance analysis test.

Note

During the test, ensure that the waveform can be clearly displayed on the screen, and there is only one USB signal waveform on the screen.

e. Press **Export Report** (as shown in the figure below) to set file storage information and save the test report.

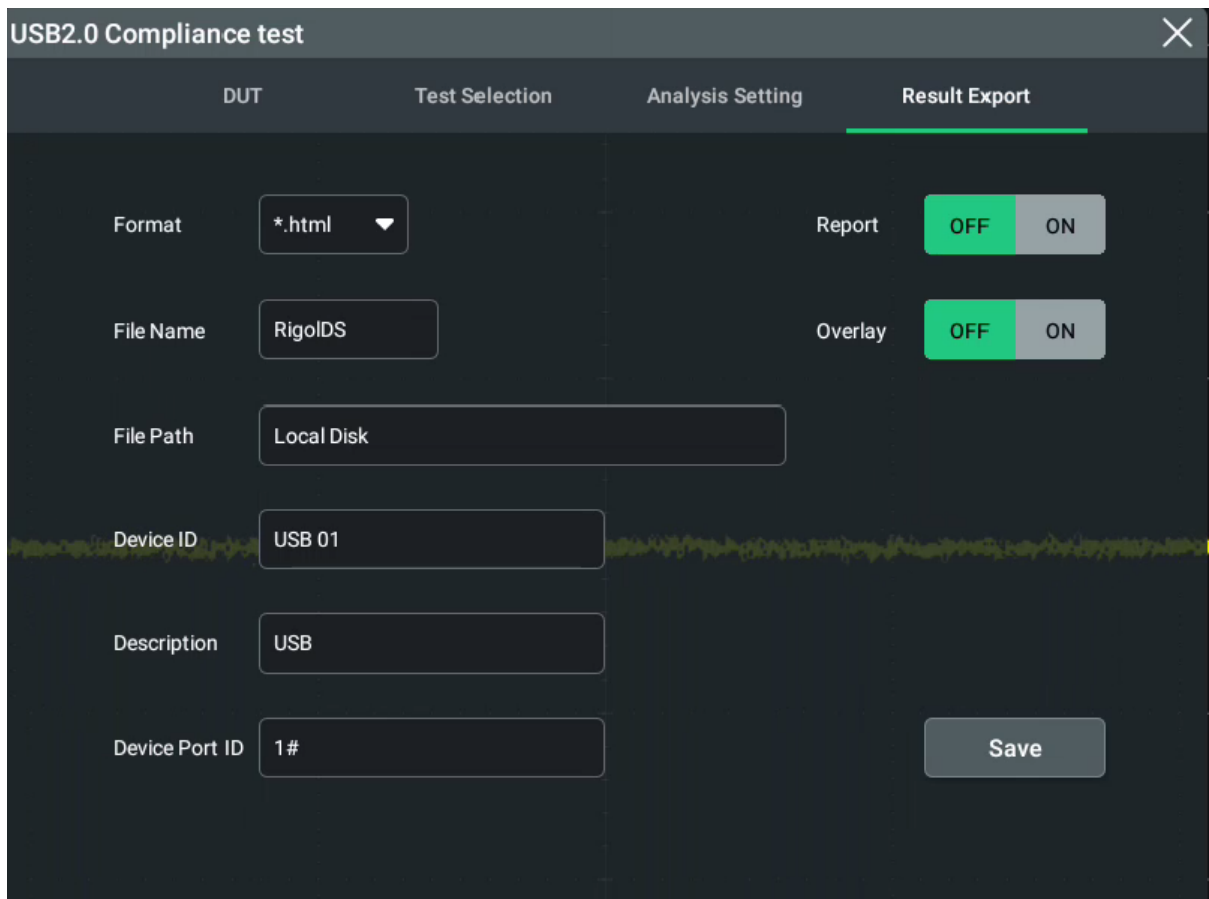

The screenshot displays the 'USB2.0 Compliance test' interface with the 'Result Export' tab selected. The interface is divided into four sections: DUT, Test Selection, Analysis Setting, and Result Export. The 'Result Export' section contains the following settings:

Field	Value	Toggle
Format	*.html	Report: OFF (checked), ON
File Name	RigolDS	Overlay: OFF (checked), ON
File Path	Local Disk	
Device ID	USB 01	
Description	USB	
Device Port ID	1#	

A 'Save' button is located at the bottom right of the 'Result Export' section.



7. After the test is completed, to restore the original host USB interface, you can choose any of the following methods:
 - Press "Return to Main" in the software to exit the "Device Test" menu, then press "Exit" to exit the program. After the program exits, the USB communication interface will be automatically reset, and the host USB interface used for testing can be restored for use.
 - Through remote control, open the computer's device manager. At this time, the original serial bus controller will be replaced by "USB Compliance Controllers". Right-press "xHCI Compliance Test Host Controller" under its directory, select "Update Driver", and then refer to the operations in "Driver Installation" to change the compatible hardware back to "USB xHCI Host Controller".

Test results:

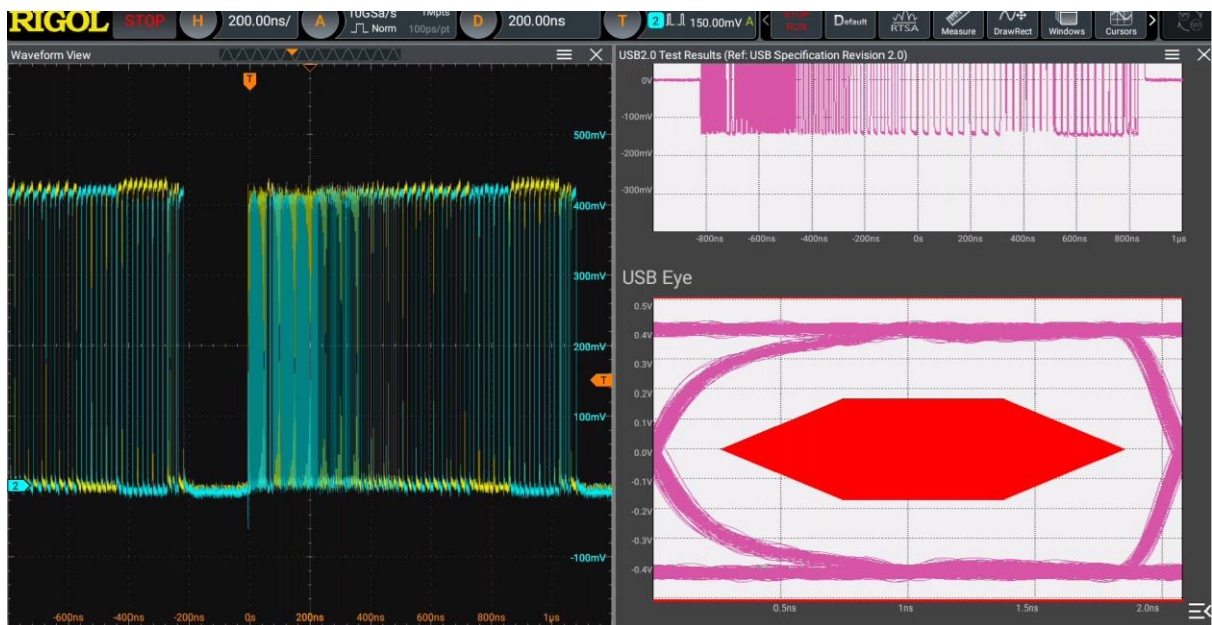

5.2 High-Speed Host Signal Quality Compliance Test

5.2.1 Test Connection Diagram

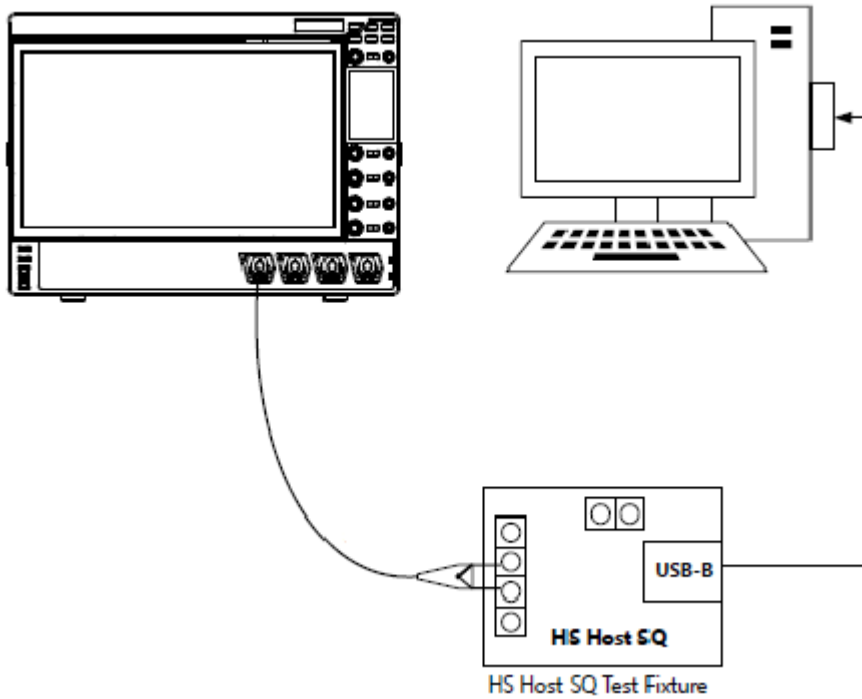

Figure 5.4 High-Speed Host Signal Quality Compliance Test (Differential Probe) Connection Diagram

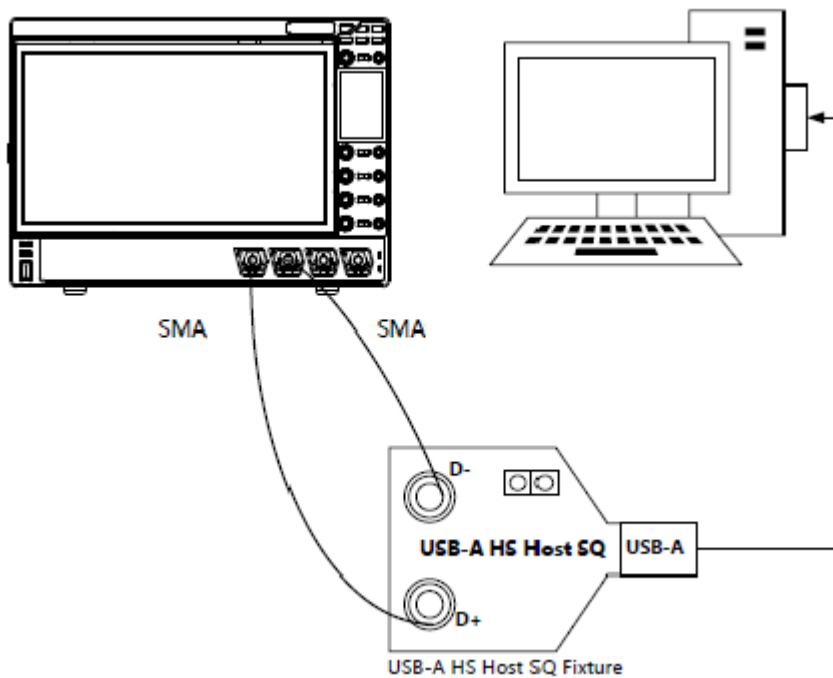

Figure 5.5 High-Speed Host Signal Quality Compliance Test (SMA Cable) Connection Diagram

Table 5.2 Tool List: High-Speed Host Signal Quality Compliance Test

Equipment	Description
Test Fixture	HS Host Electrical Test Fixture (Differential Probe) USB-A HS Host SQ Fixture (SMA Cable)
Oscilloscope	2.0 GHz or higher bandwidth, 5 GSa/s or higher sample rate, RIGOL DS70000 series oscilloscope recommended
Host Under Test	Has a USB 2.0 interface
Differential probe or SMA cable	Connect fixture to oscilloscope

5.2.2 Test Steps

Before starting the test, please prepare the necessary tools.

1. Connect the fixture, oscilloscope, and device under test according to the method in the test connection diagram.
2. Switch or install the driver according to the "Driver Installation" section.
3. After successful installation, open the "XHCI HSETT" software, select the correct controller, then select "Host Controller/System" as the test object, and then press TEST to start the test.

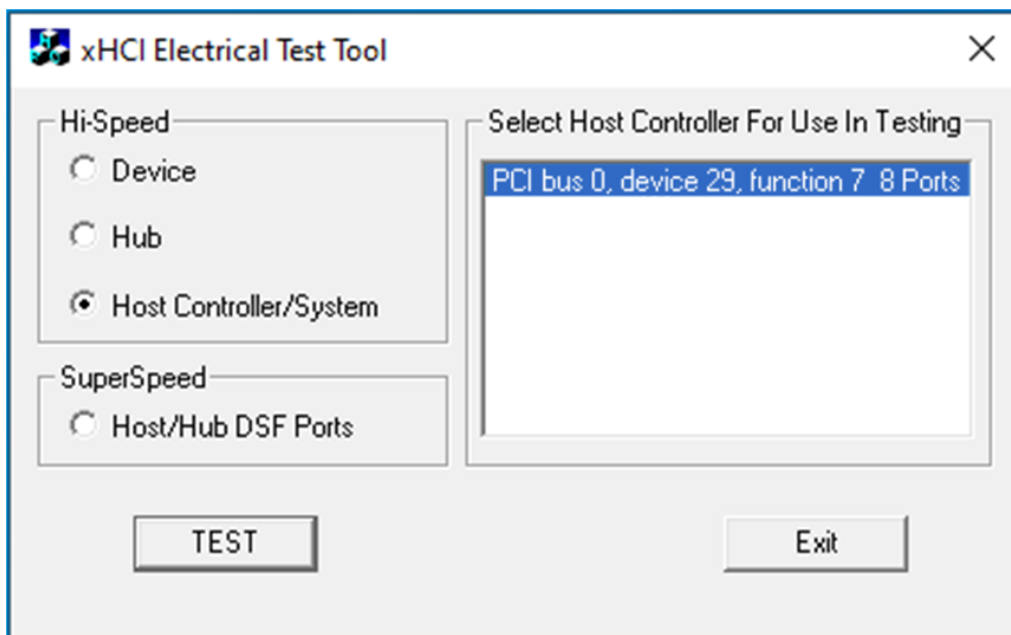

4. Press the Enumerate Bus button to refresh the host port, select "TEST_PACKET" in "Port Control", set "Port" to the host port number connected to the fixture (i.e., if the currently connected host port number is 3, it should be set to 3). Press EXECUTE after selection. If the Status Window prompts "Operation Successful", it means the selected signal output is successful, and you can obtain the signal through the oscilloscope and then start the compliance analysis.

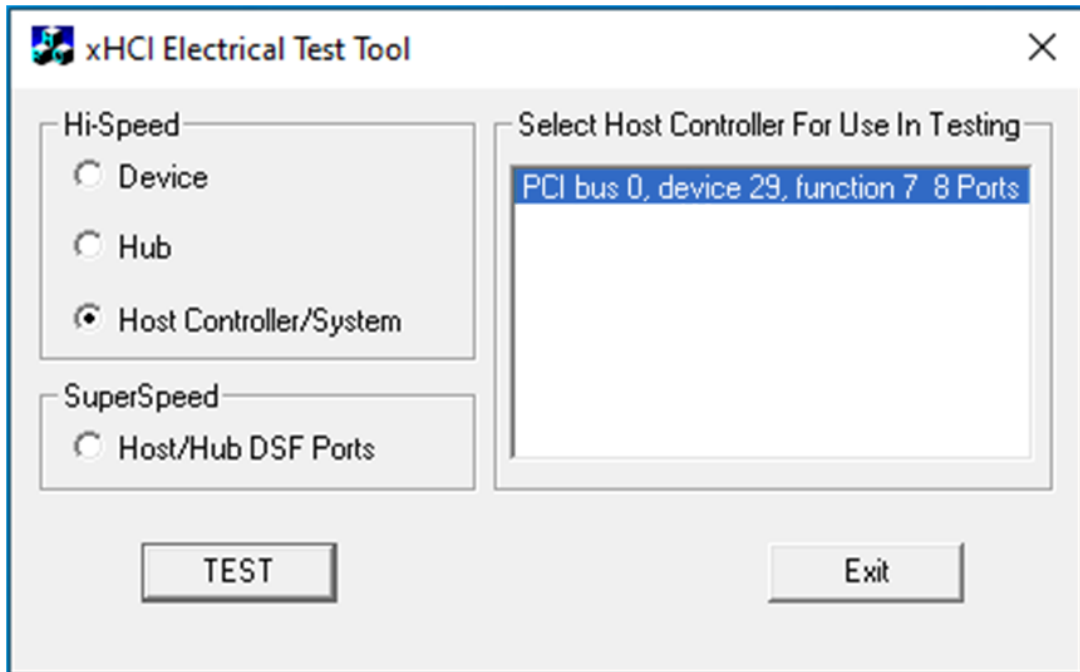
**Note**

The host has multiple ports. If you are unsure which port the test fixture is connected to, you can unplug other USB devices and only keep the USB connection of the test fixture.

5. Start the test (taking the DS70000 series oscilloscope as an example):
 - a. Press > to open the "USB2.0 Compliance Analysis Interface".
 - b. In the **Device Under Test** interface (as shown in the figure below), select "Host", "High Speed" respectively, and select "Endpoint" according to the actual situation.

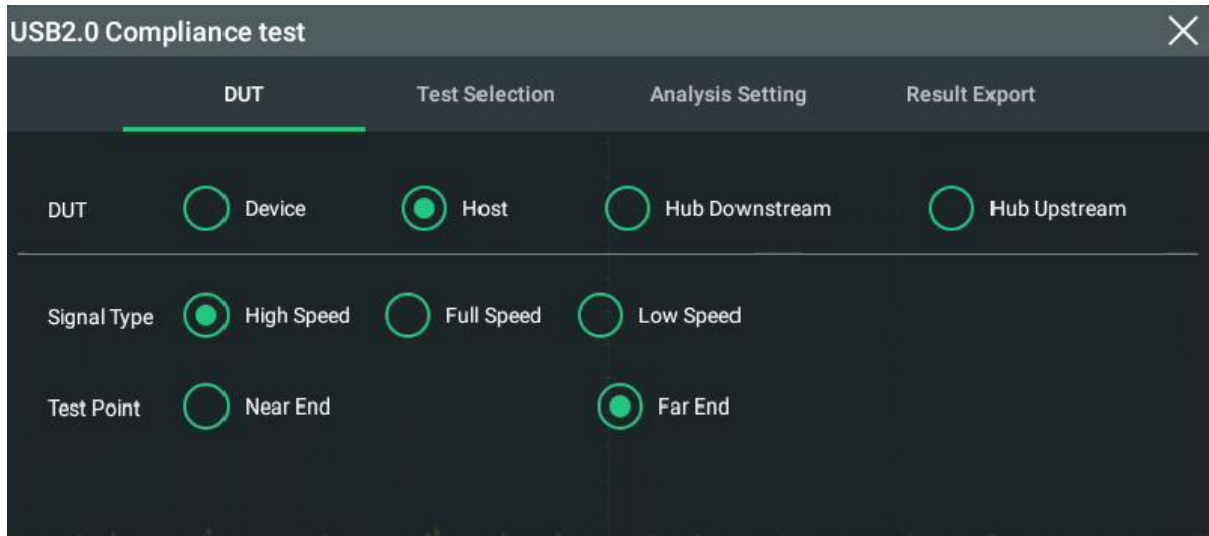

Note

When the signal type is "High Speed", users can choose "Near End" or "Far End" according to the test scenario. The selection of "Near End" and "Far End" depends on the test port situation of the device under test, as shown in the figure below.

- When there is no USB Cable between the device under test and the host, and the test point is at TP3, according to the USB2.0 protocol content, the eye diagram template selects Template1, and at this time, the user selects "Near End".
- When there is a USB Cable between the device under test and the host, and the test point is at TP2, according to the USB2.0 protocol content, the eye diagram template selects Template2, and at this time, the user selects "Far End".

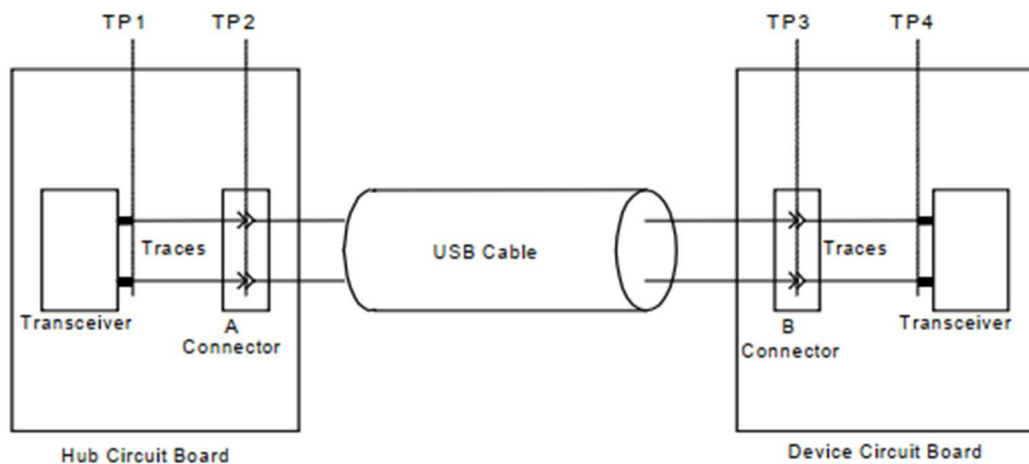
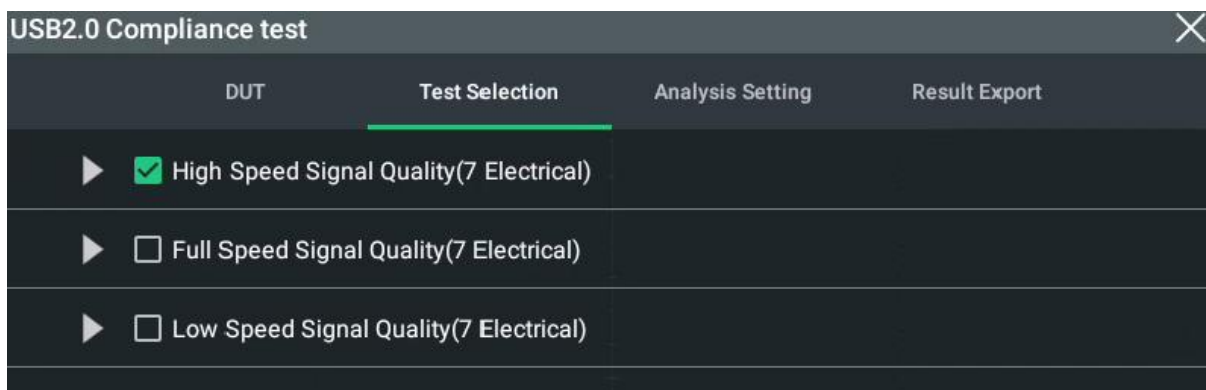
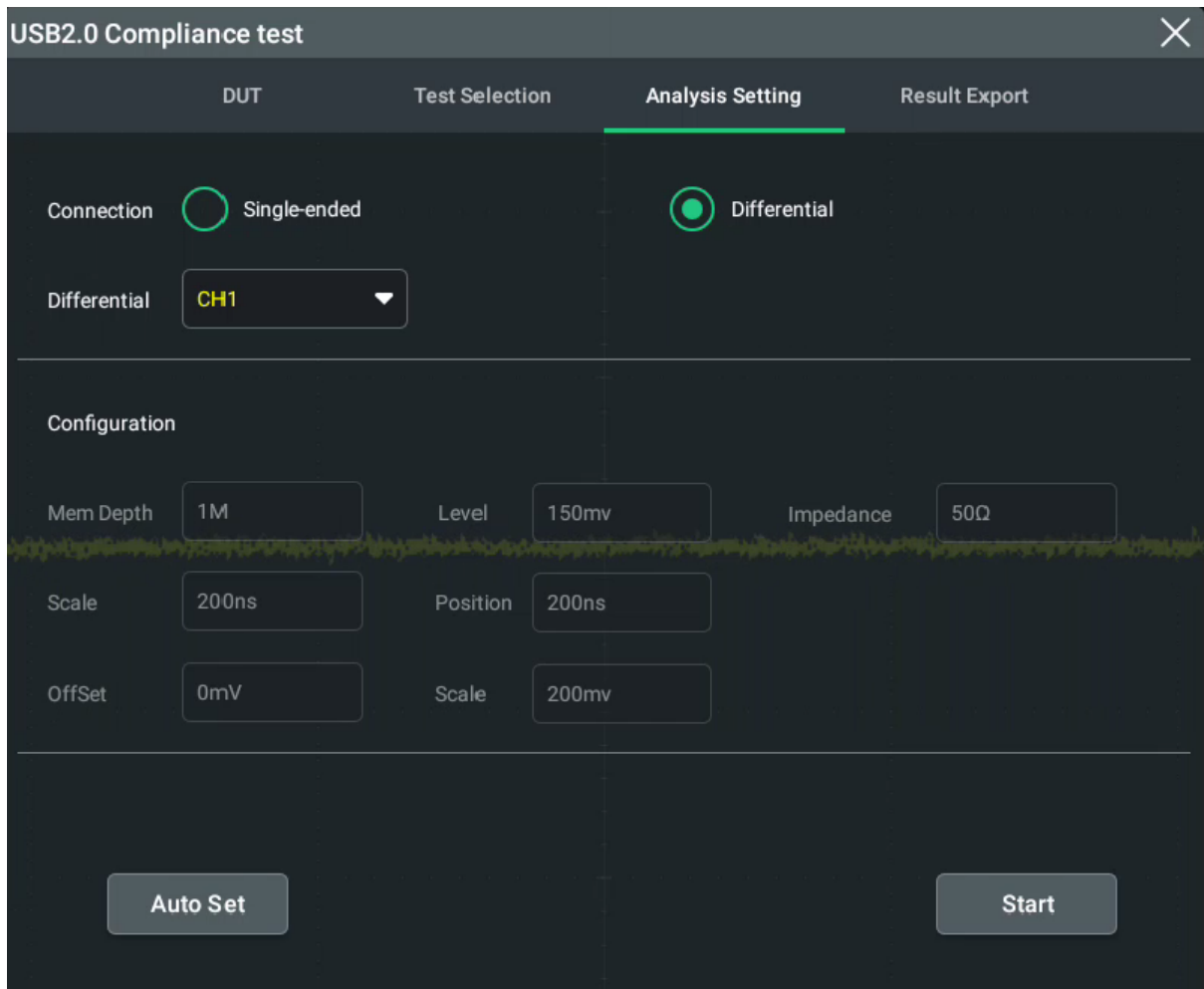

Figure 5.6 USB2.0 Test Model

c. Press to open the **Test Items** interface (as shown in the figure below), and select "High Speed Signal Quality (7 Electrical)".



d. Press to open the **Analysis Settings** interface (as shown in the figure below), and select "SMA Cable Connection" or "Differential Probe" in the "Test Connection" item according to the actual situation; and select the test "Signal Source".



Press **Auto Set**, the oscilloscope will automatically set the configuration information, and finally press **Start Measurement** to perform USB2.0 signal quality compliance analysis test.

Note

During the test, ensure that the waveform can be clearly displayed on the screen, and there is only one USB signal waveform on the screen.

e. Press **Export Report** (as shown in the figure below) to set file storage information and save the test report.

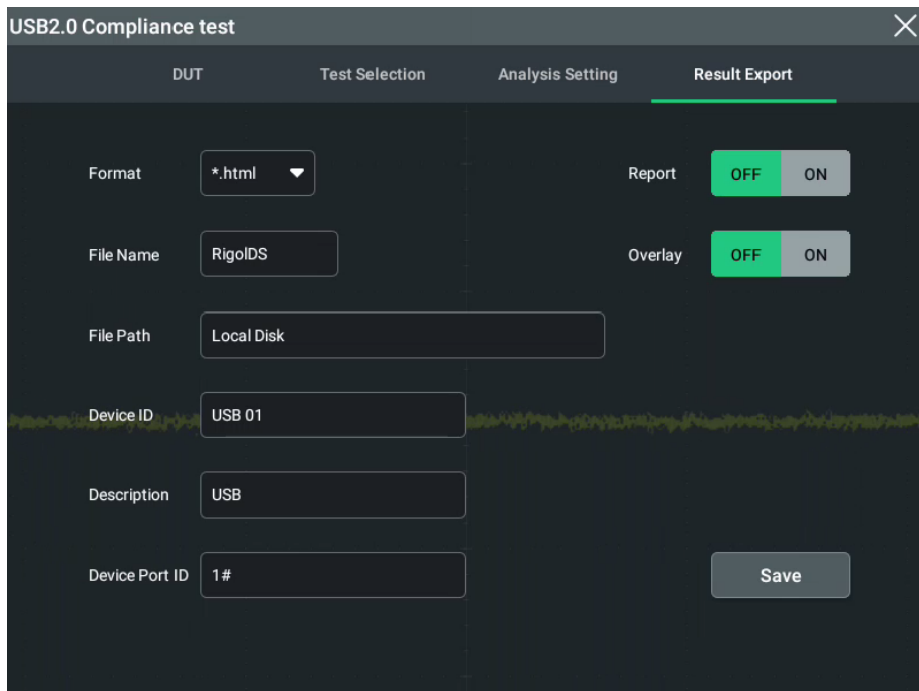

USB2.0 Compliance test

DUT Test Selection Analysis Setting **Result Export**

Format: *.html

File Name: RigolDS

File Path: Local Disk

Device ID: USB 01

Description: USB

Device Port ID: 1#

Report: OFF ON

Overlay: OFF ON

Save

6. After the test is completed, to restore the original host USB interface, you can choose any of the following methods:
 - Press "Return to Main" in the software to exit the "Host Test" menu, then press "Exit" to exit the program. After the program exits, the USB communication interface will be automatically reset, and the host USB interface used for testing can be restored for use.
 - Through remote control, open the computer's device manager. At this time, the original serial bus controller will be replaced by "USB Compliance Controllers". Right-click "xHCI Compliance Test Host Controller" under its directory, select "Update Driver", and then refer to the operations in "Driver Installation" to change the compatible hardware back to "USB xHCI Host Controller".

Test Results:

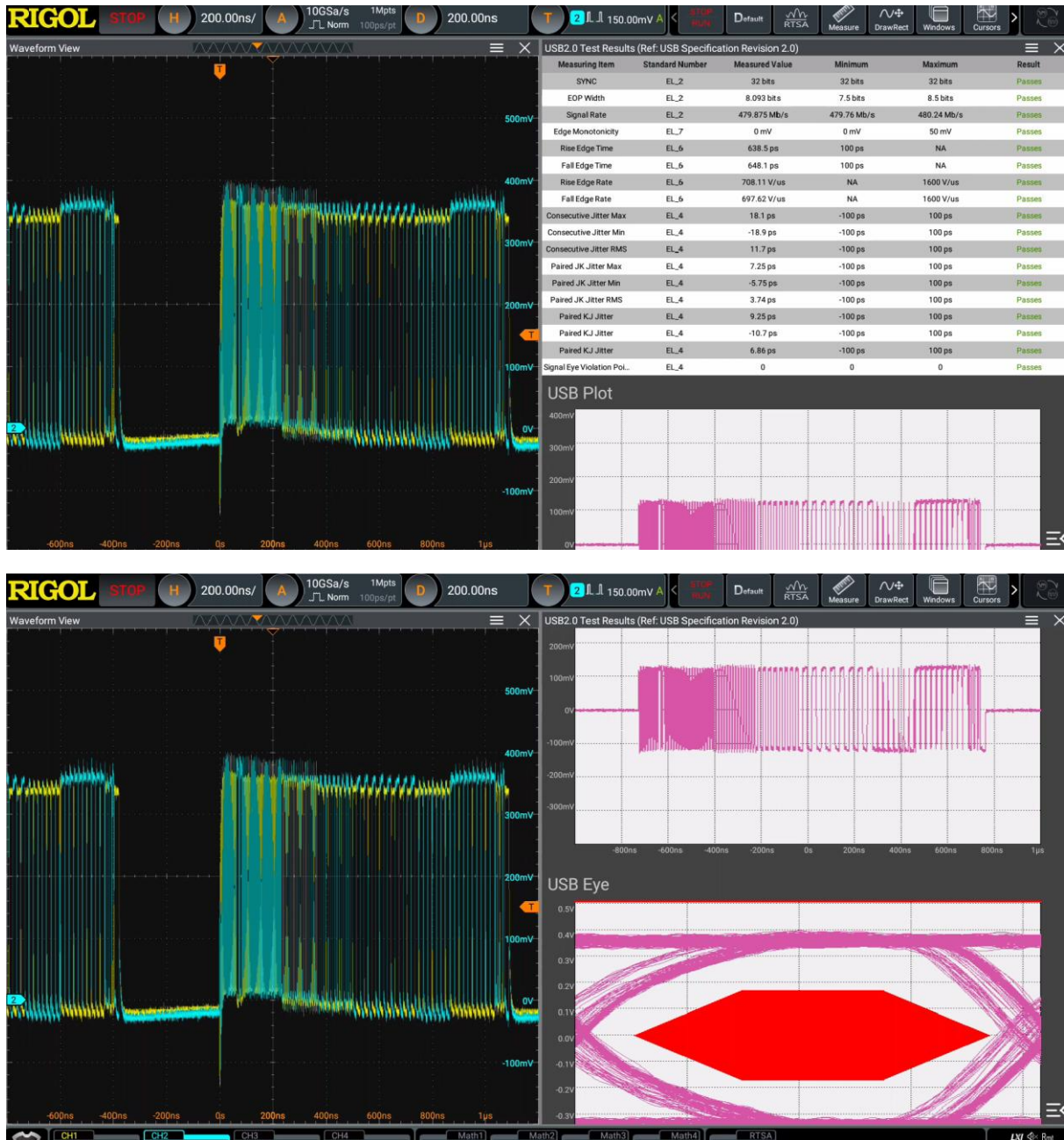

5.3 Hub Upstream High-Speed Signal Quality Compliance Test

5.3.1 Test Connection Diagram

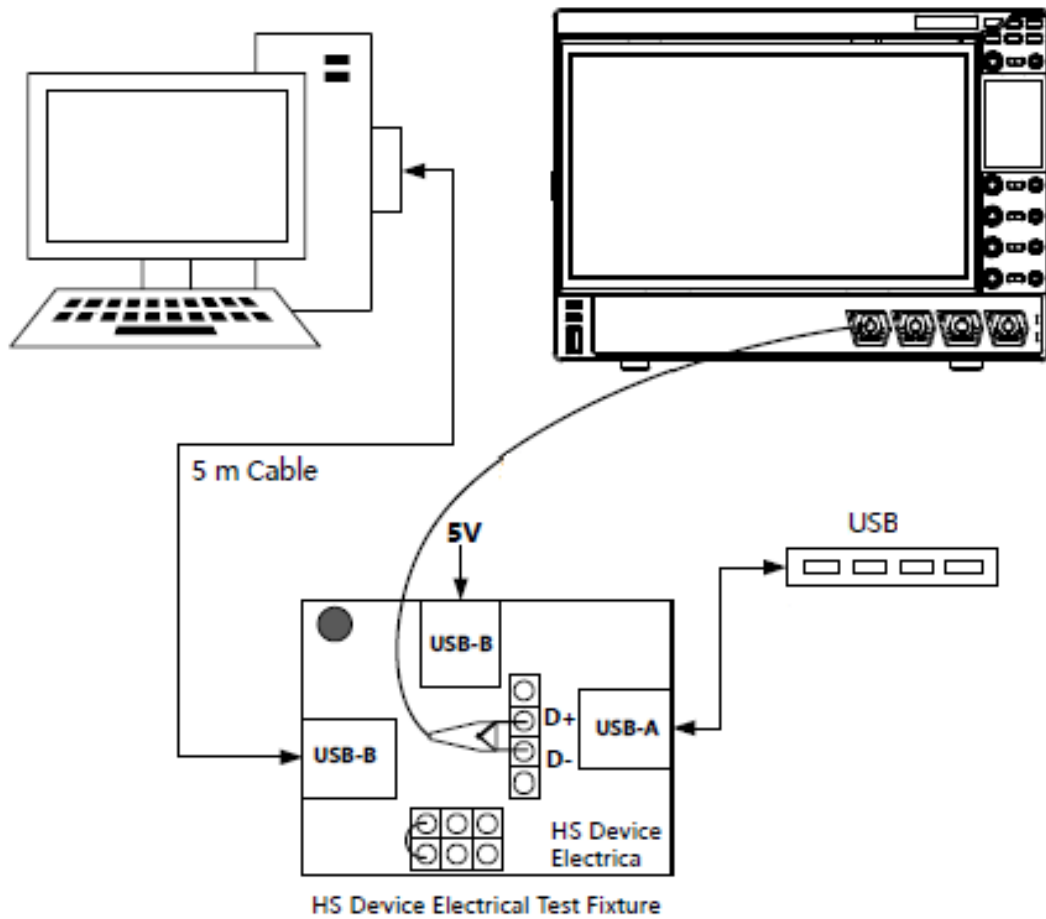

Figure 5.7 Hub Upstream High-Speed Signal Quality Compliance Test (Differential Probe) Connection Diagram

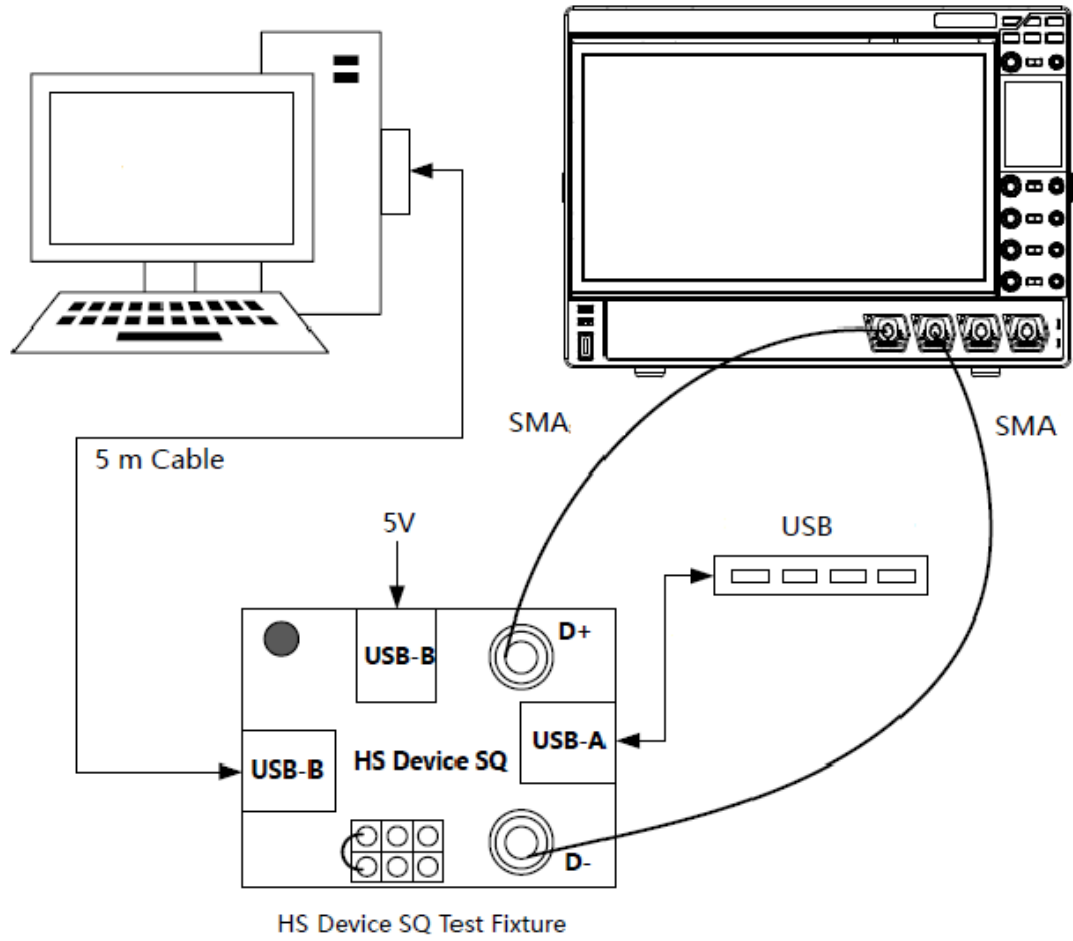

Figure 5.8 Hub Upstream High-Speed Signal Quality Compliance Test (SMA Cable) Connection Diagram

Table 5.3 Tool List: Hub Upstream High-Speed Signal Quality Compliance Test

Equipment	Description
Test Fixture	HS Device Electrical Test Fixture (Differential Probe) HS Device SQ Test Fixture (SMA Cable)
Oscilloscope	2.0 GHz or higher bandwidth, 5 GSa/s or higher sample rate, RIGOL DS70000 series oscilloscope recommended
USB Hub Under Test	Upstream port is USB2.0 interface
High-speed Test Host	Has a USB 2.0 interface
USB-A male to USB-B male cable	2 cables, connect fixture to USB hub, and fixture to power respectively
Differential probe or SMA cable	Connect fixture to oscilloscope
Jumper cap	Used to short pins 5 and 6 of the gold pin header

5.3.2 Test Steps

Before starting the test, please prepare the necessary tools.

Tip

Before testing, please keep the fixture's Test switch OFF.

1. Connect the fixture, oscilloscope, and device under test according to the method in the test connection diagram.
2. Switch or install the driver according to the "Driver Installation" section.
3. After successful installation, open the "XHCI HSETT" software, select the correct controller, then select "Hub" as the high-speed test object, and then press TEST to start the test.

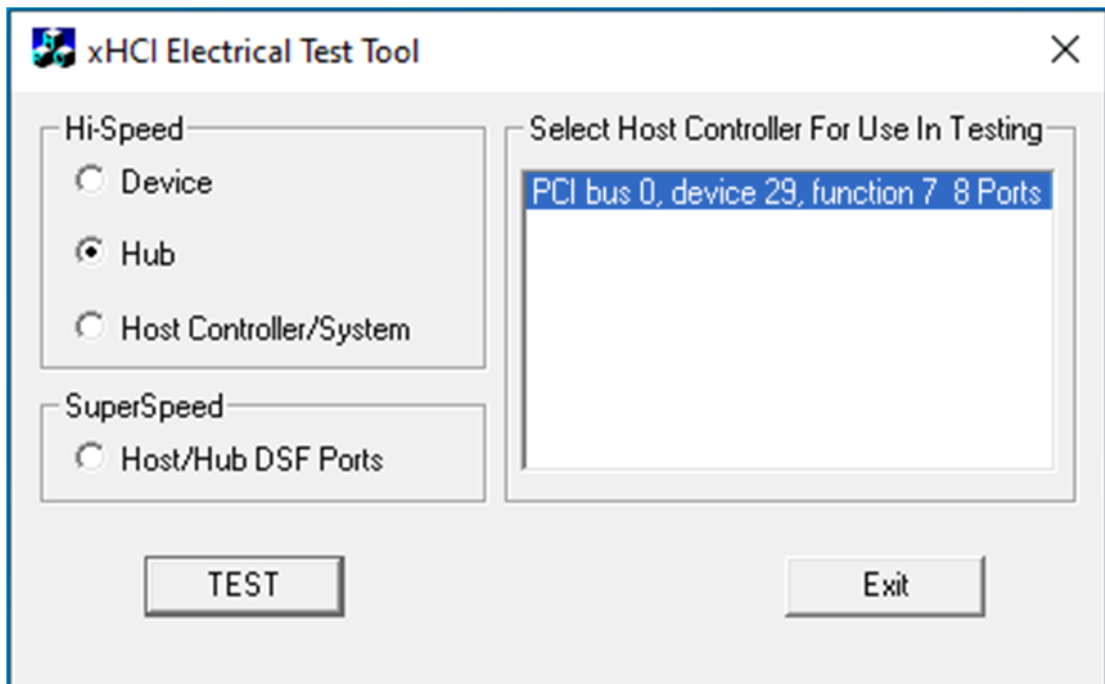

4. Press the Enumerate Bus button to refresh the host port, select "TEST_PACKET" in "Hub Command", press EXECUTE after selection. If the Status Window prompts "Operation Successful", it means the selected signal output is successful.

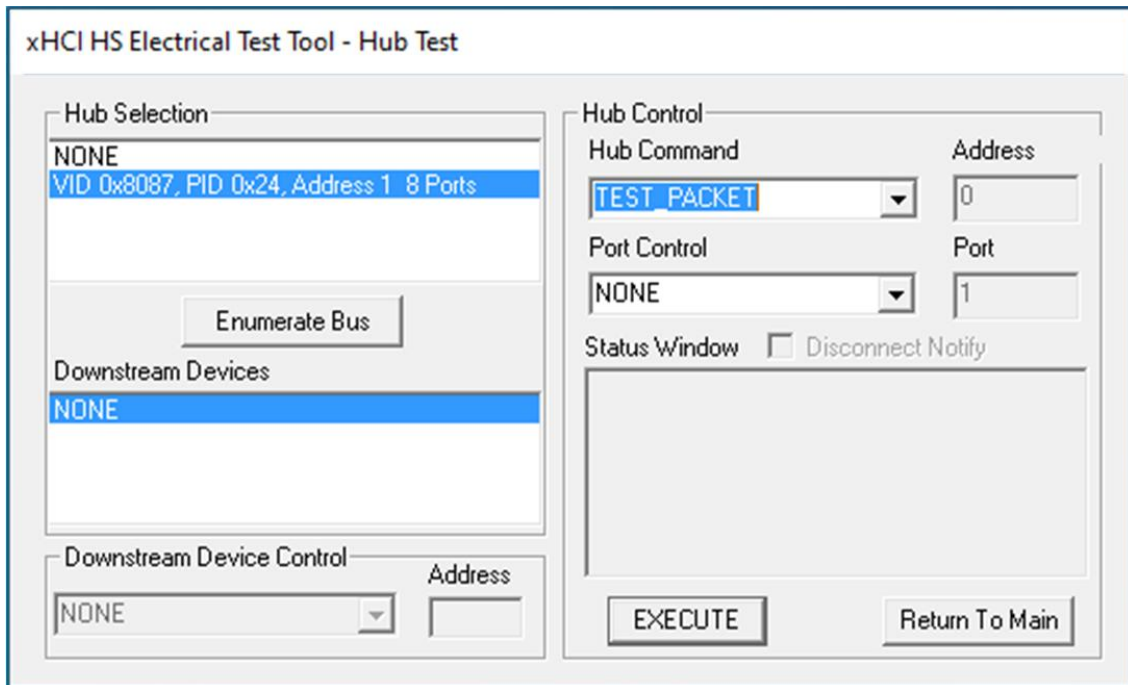

5. Finally, turn on the Test switch of the fixture. At this time, both signal lights of the fixture will light up, and you can obtain the signal through the oscilloscope and then start the compliance analysis.

6. Start the test (taking the DS70000 series oscilloscope as an example):
 - a. Open the "USB2.0 Compliance Analysis Interface".
 - b. In the **Device Under Test** interface (as shown in the figure below), select "Hub Upstream", "High Speed" respectively, and select "Endpoint" according to the actual situation.

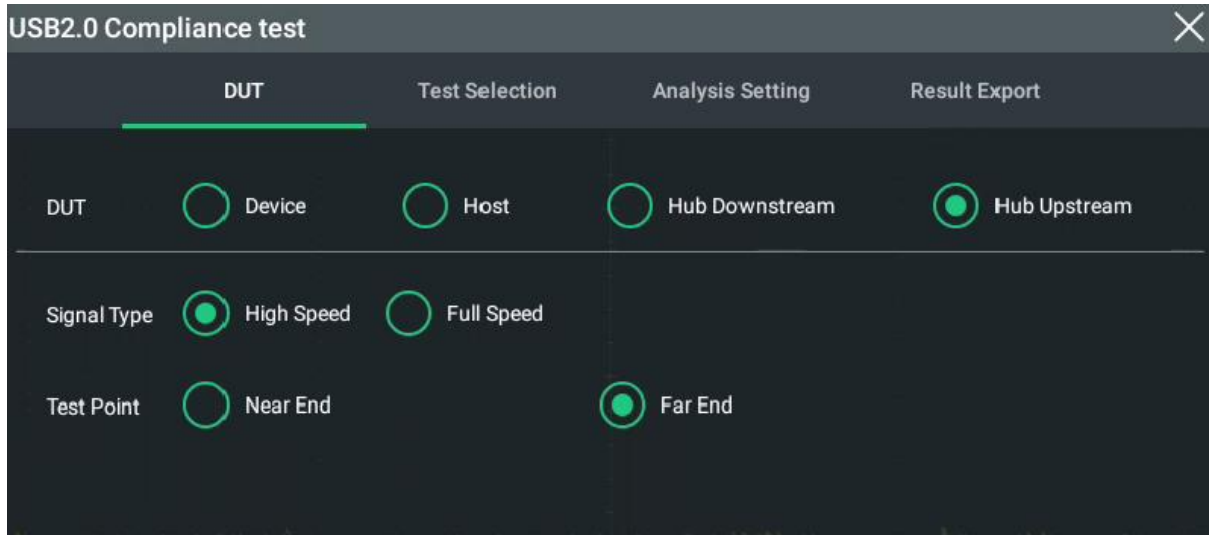

Note

When the signal type is "High Speed", users can choose "Near End" or "Far End" according to the test scenario. The selection of "Near End" and "Far End" depends on the test port situation of the device under test, as shown in the figure below.

- When there is no USB Cable between the device under test and the host, and the test point is at TP3, according to the USB2.0 protocol content, the eye diagram template selects Template1, and at this time, the user selects "Near End".
- When there is a USB Cable between the device under test and the host, and the test point is at TP2, according to the USB2.0 protocol content, the eye diagram template selects Template2, and at this time, the user selects "Far End".

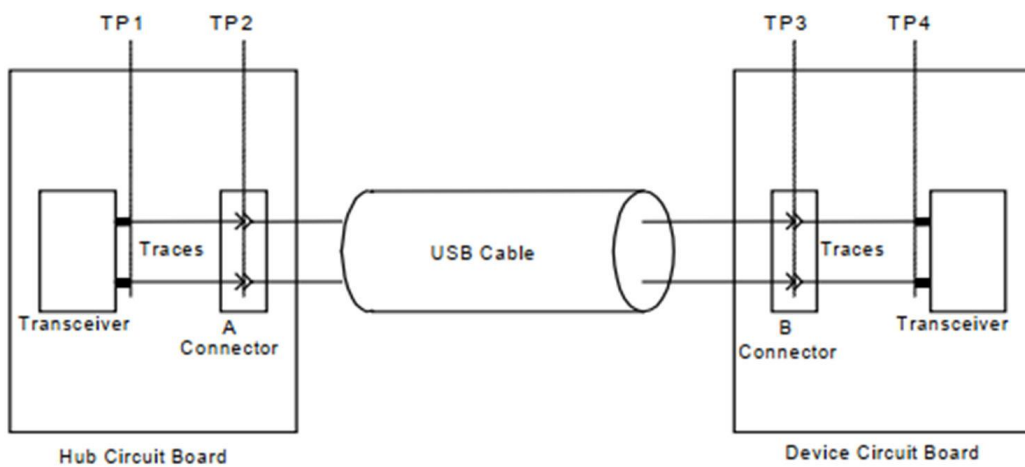
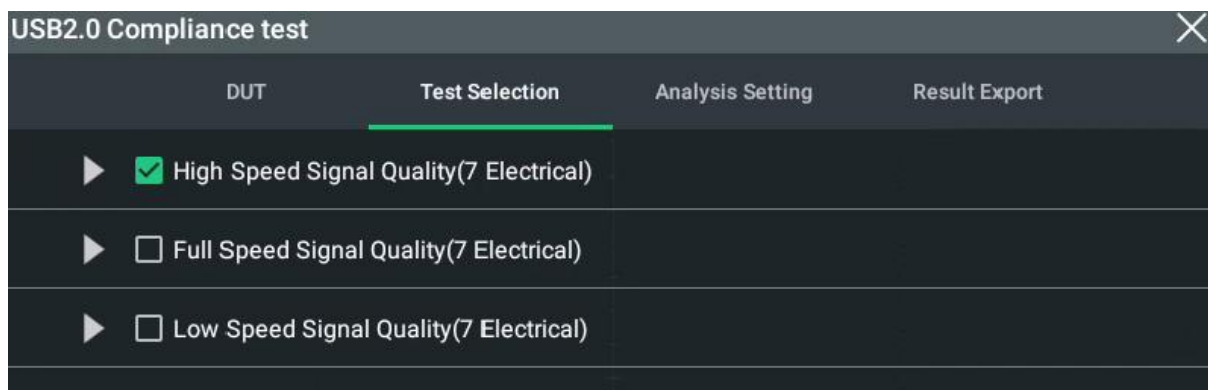
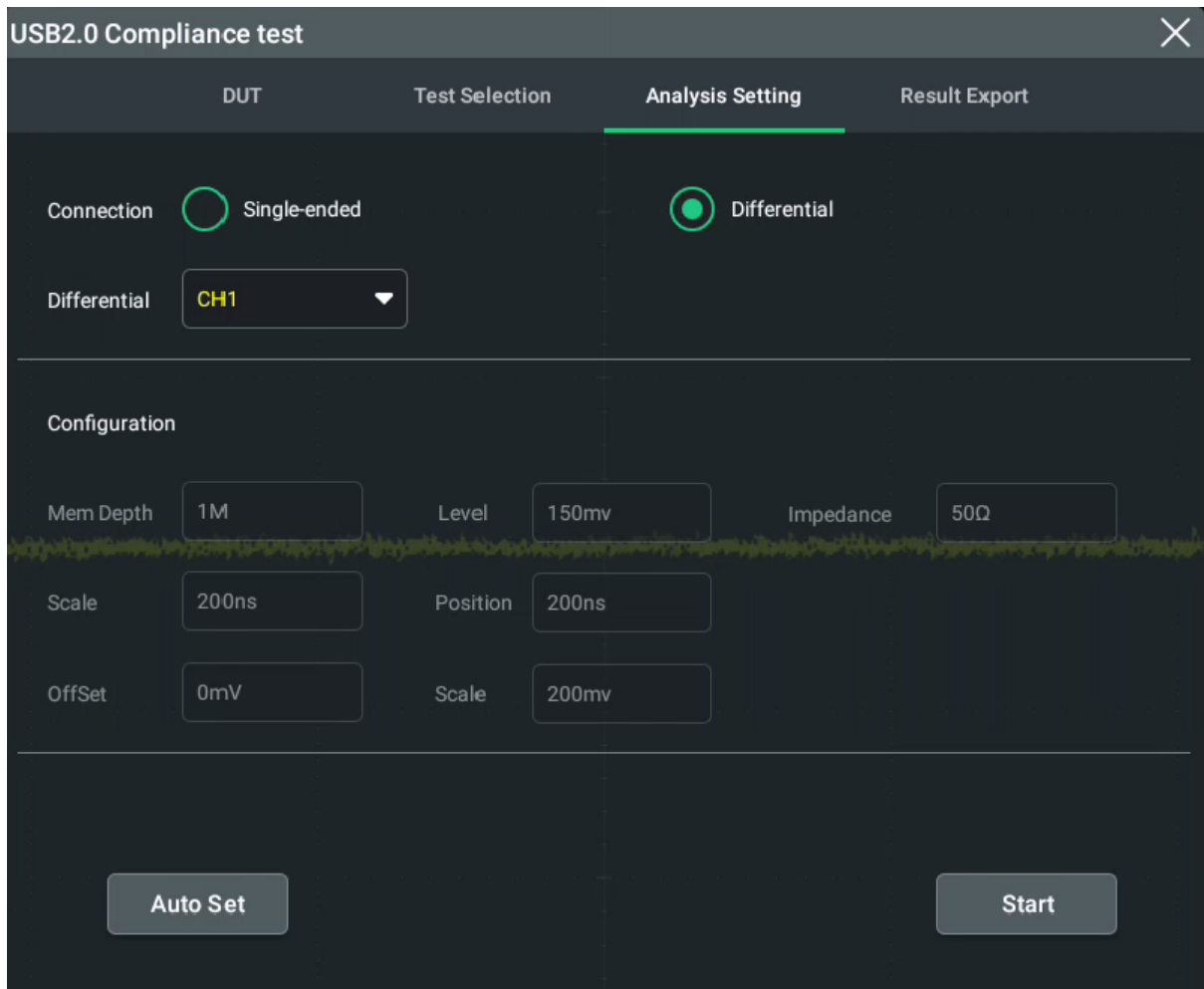

Figure 5.9
USB2.0
Test
Model

c. Press to open the **Test Items** interface (as shown in the figure below), and select "High Speed Signal Quality (7 Electrical)".



d. Press to open the **Analysis Settings** interface (as shown in the figure below), and select "SMA Cable Connection" or "Differential Probe" in the "Test Connection" item according to the actual situation; and select the test "Signal Source".



Press **Auto Set**, the oscilloscope will automatically set the configuration information, and finally press **Start Measurement** to perform USB2.0 signal quality compliance analysis test.

Note

During the test, ensure that the waveform can be clearly displayed on the screen, and there is only one USB signal waveform on the screen.

e. Press **Export Report** (as shown in the figure below) to set file storage information and save the test report.

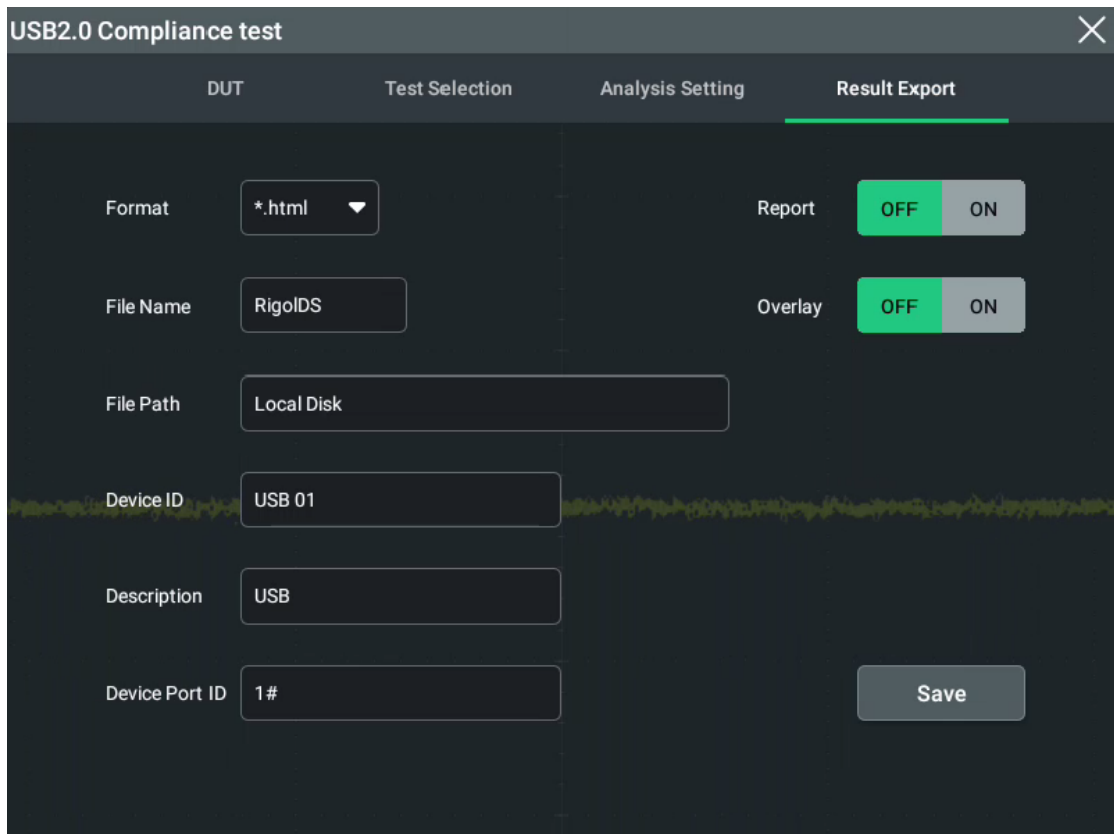

7. After the test is completed, to restore the original host USB interface, you can choose any of the following methods:

- Press "Return to Main" in the software to exit the "Hub Test" menu, then press "Exit" to exit the program. After the program exits, the USB communication interface will be automatically reset, and the host USB interface used for testing can be restored for use.
- Through remote control, open the computer's device manager. At this time, the original serial bus controller will be replaced by "USB Compliance Controllers". Right-press "xHCI Compliance Test Host Controller" under its directory, select "Update Driver", and then refer to the operations in "Driver Installation" to change the compatible hardware back to "USB xHCI Host Controller".

5.4 Hub Downstream High-Speed Signal Quality Compliance Test

5.4.1 Test Connection Diagram

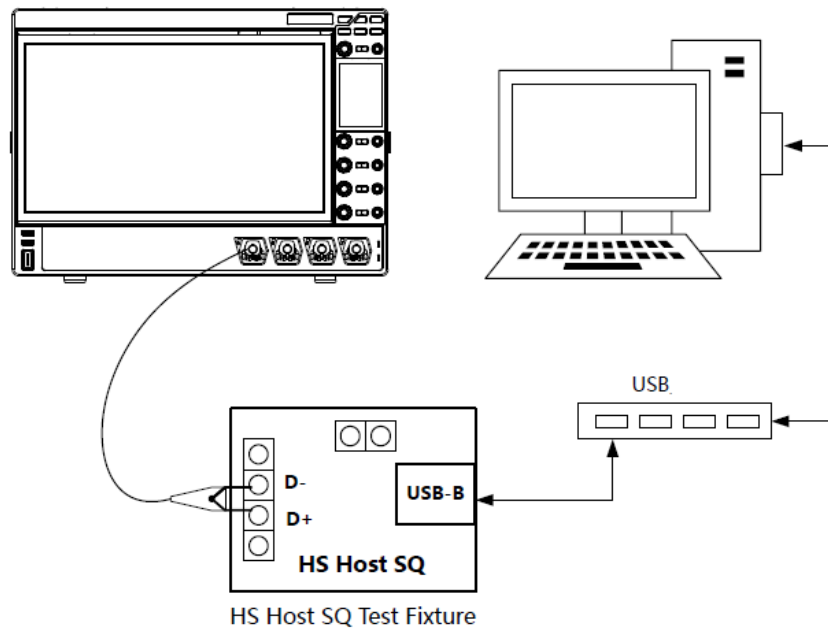

Figure 5.10 Hub Downstream High-Speed Signal Quality Compliance Test (Differential Probe) Connection Diagram

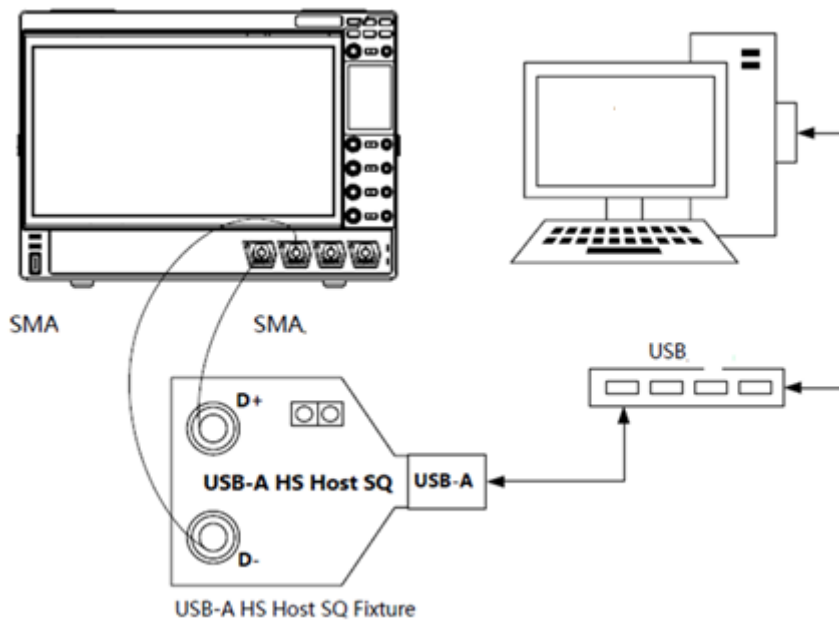

Figure 5.11 Hub Downstream High-Speed Signal Quality Compliance Test (SMA Cable) Connection Diagram

Table 5.4 Tool List: Hub Downstream High-Speed Signal Quality Compliance Test

Equipment	Description
Test Fixture	HS Host Electrical Test Fixture (Differential Probe) USB-A HS Host SQ Fixture (SMA Cable)
Oscilloscope	2.0 GHz or higher bandwidth, 5 GSa/s or higher sample rate, RIGOL DS70000 series oscilloscope recommended
USB Hub Under Test	Downstream port is USB2.0 interface
High-speed Test Host	Has a USB 2.0 interface
Differential probe or SMA cable	Connect fixture to oscilloscope

5.4.2 Test Steps

Before starting the test, please prepare the necessary tools.

1. Connect the test setup and equipment according to the method in the test connection diagram.
2. Switch or install the driver according to the "Driver Installation" section.
3. After successful installation, open the "XHCI HSETT" software, select the correct controller, then select "Hub" as the test object, and then press TEST to start the test.

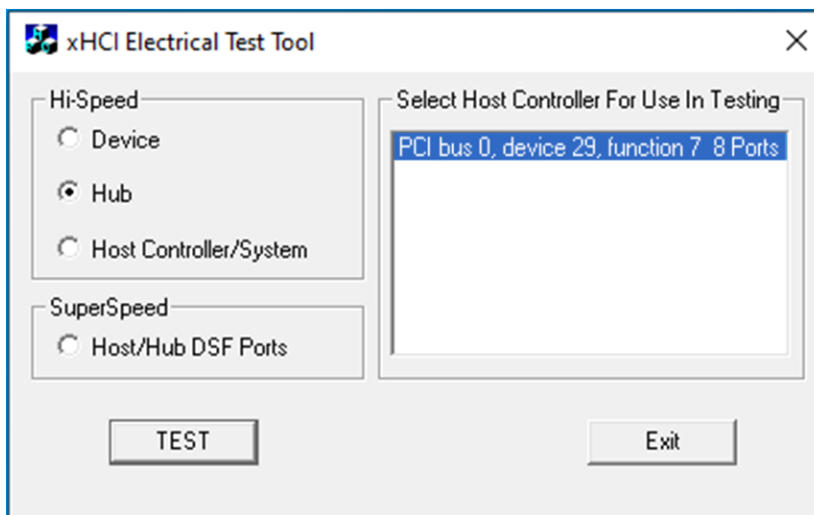

4. Press the Enumerate Bus button to refresh the host port, select "TEST_PACKET" in "Port Control", set "Port" to the hub port number connected to the fixture (i.e., if the currently connected hub port number is 3, it should be set to 3). Press EXECUTE after selection. If the Status Window prompts "Operation Successful", it means the selected signal output is successful, and you can obtain the signal through the oscilloscope and then start the compliance analysis.

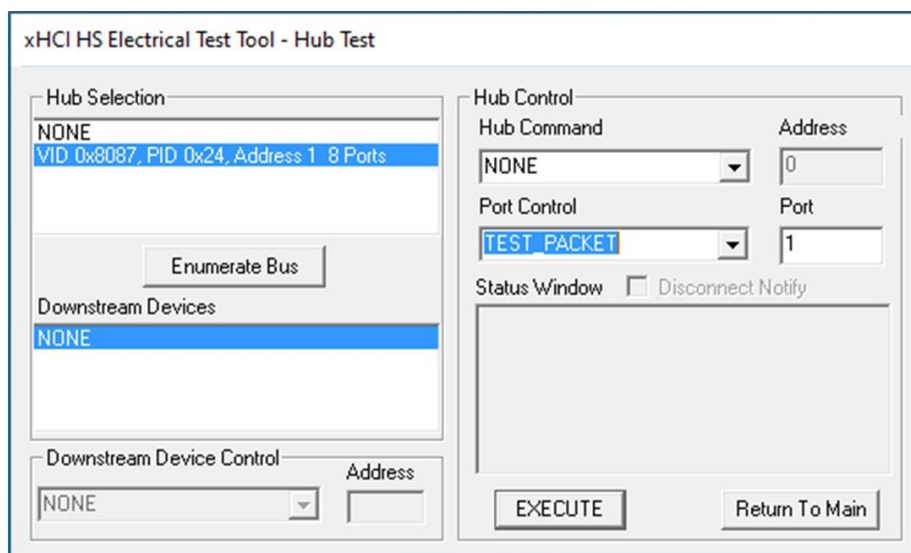

Note

The hub has multiple ports. If you are unsure which port the test fixture is connected to, you can unplug other USB devices and only keep the USB connection of the test fixture.

5. Start the test (taking the DS70000 series oscilloscope as an example):

a. Press > to open the "USB2.0 Compliance Analysis Interface".

b. In the **Device Under Test** interface (as shown in the figure below), select "Hub Downstream", "High Speed" respectively, and select "Endpoint" according to the actual situation.

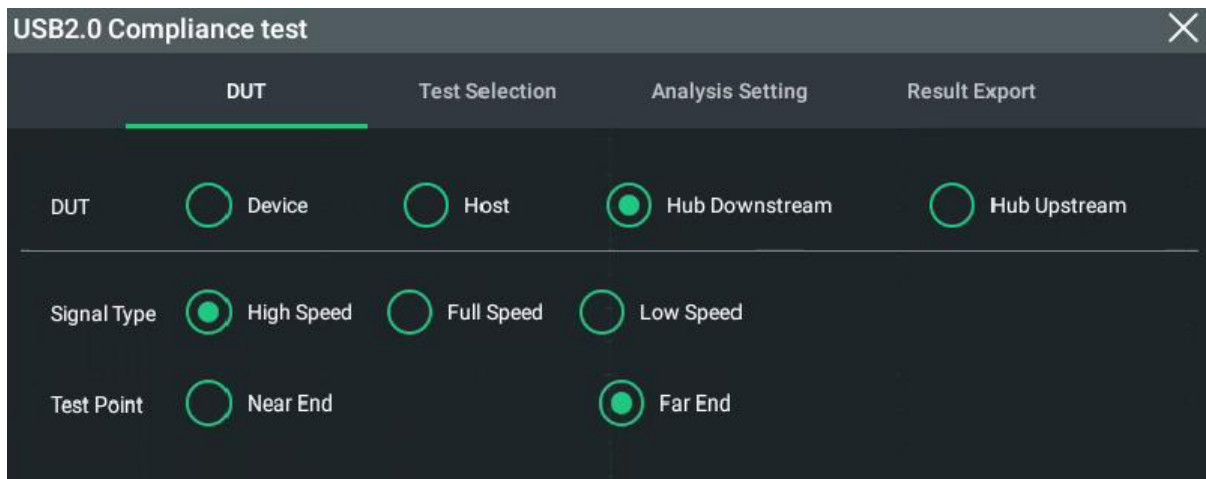

c. Press to open the **Test Items** interface (as shown in the figure below), and select "High Speed Signal Quality (7 Electrical)".

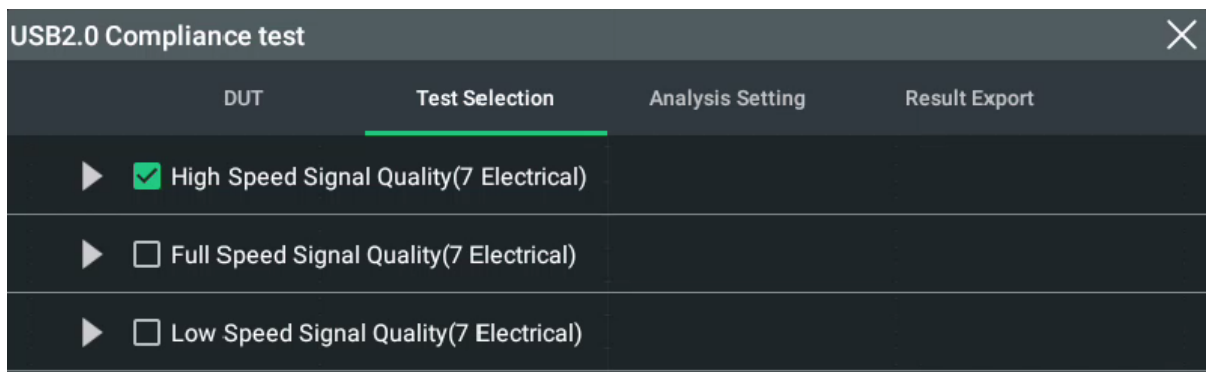

d. Press to open the **Analysis Settings** interface (as shown in the figure below), and select Single-ended "SMA Cable Connection" or "Differential Probe" in the "Test Connection" item according to the actual situation; and select the test "Signal Source".

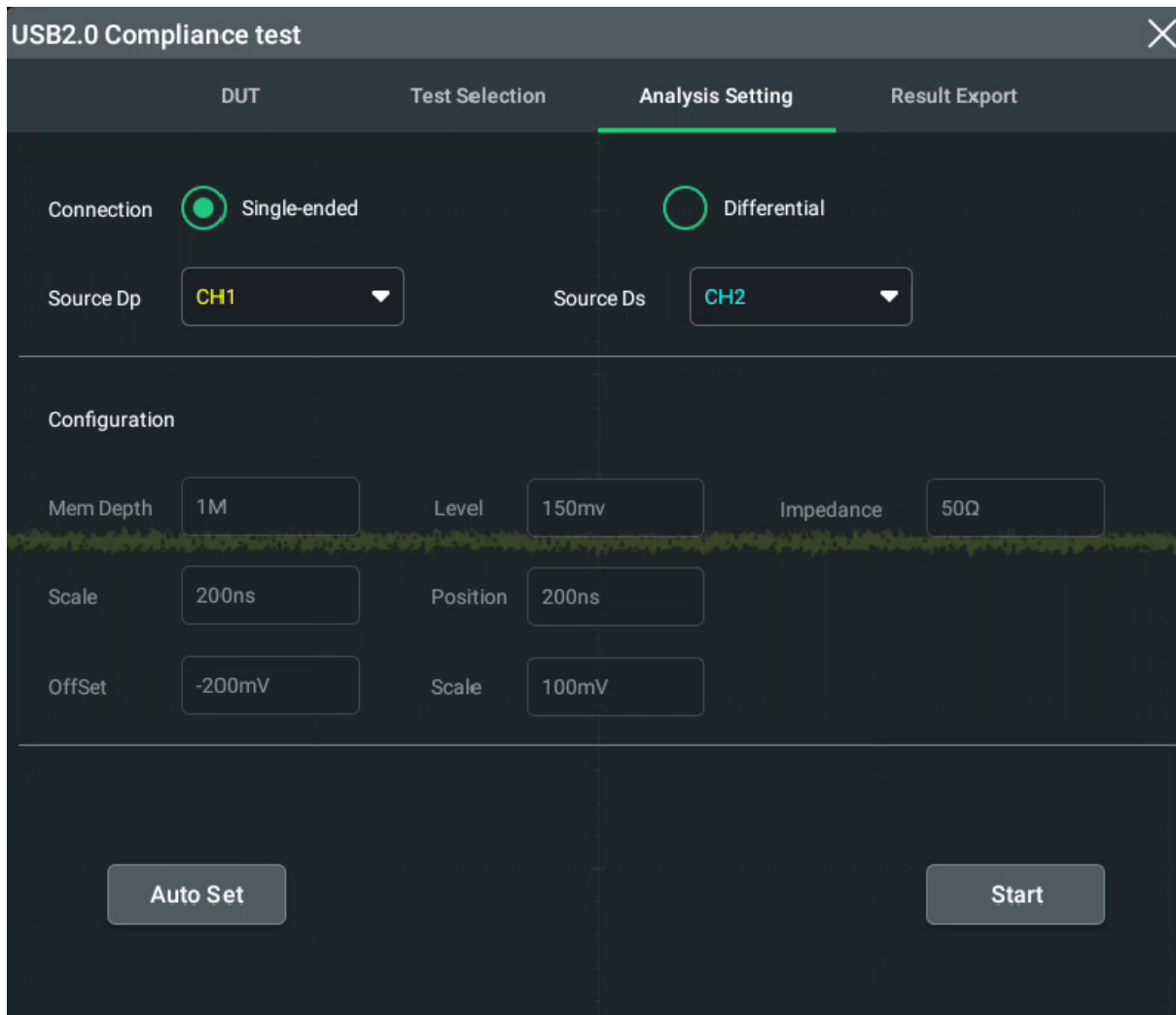

Press **Auto Set**, the oscilloscope will automatically set the configuration information, and finally press **Start Measurement** to perform USB2.0 signal quality compliance analysis test.

Note

During the test, ensure that the waveform can be clearly displayed on the screen, and there is only one USB signal waveform on the screen.

e. Press **Export Report** (as shown in the figure below) to set file storage information and save the test report.

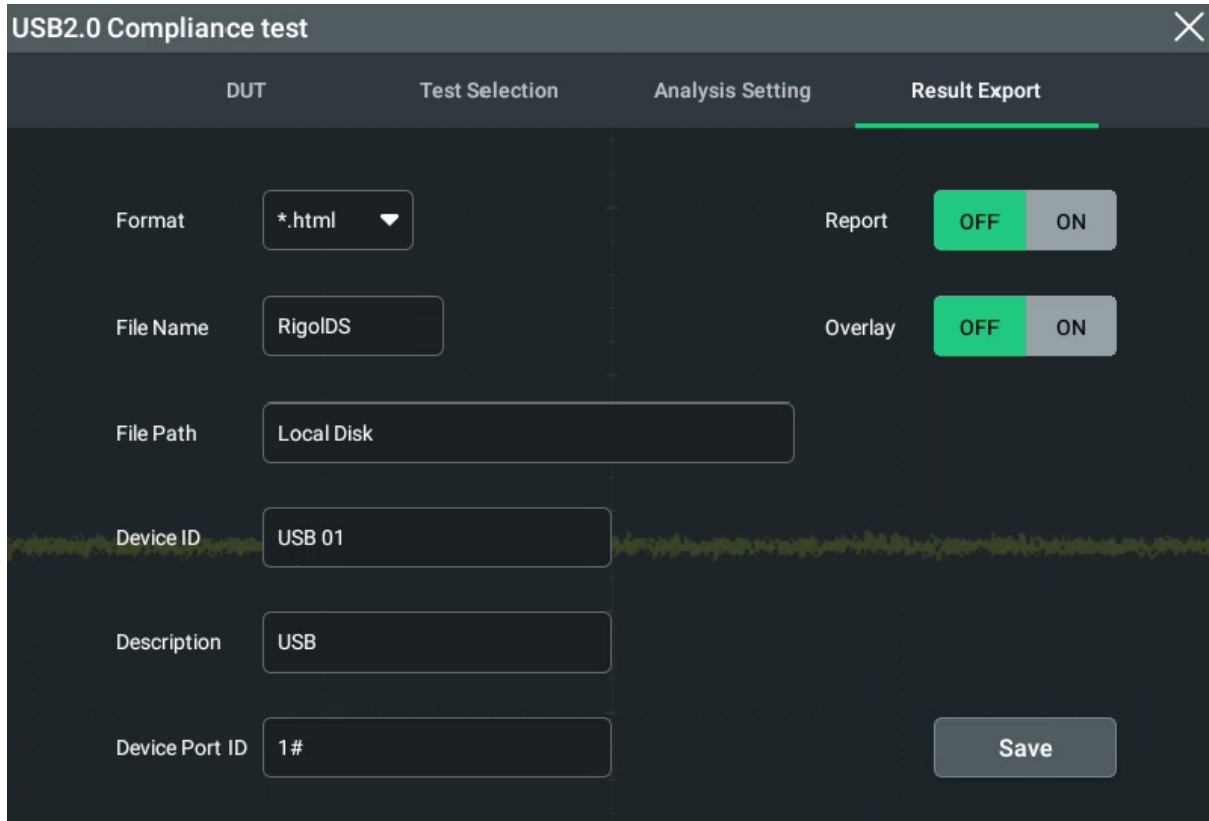

The screenshot displays the 'USB2.0 Compliance test' software interface, specifically the 'Result Export' tab. The interface is dark-themed and features a navigation bar at the top with four tabs: 'DUT', 'Test Selection', 'Analysis Setting', and 'Result Export'. The 'Result Export' tab is currently selected and highlighted with a green underline. Below the navigation bar, the interface is divided into two columns. The left column contains several input fields: 'Format' (set to '*.html'), 'File Name' (set to 'RigolDS'), 'File Path' (set to 'Local Disk'), 'Device ID' (set to 'USB 01'), 'Description' (set to 'USB'), and 'Device Port ID' (set to '1#'). The right column contains two toggle switches: 'Report' (set to 'OFF') and 'Overlay' (set to 'OFF'). A 'Save' button is located at the bottom right of the interface.

Field	Value
Format	*.html
File Name	RigolDS
File Path	Local Disk
Device ID	USB 01
Description	USB
Device Port ID	1#
Report	OFF
Overlay	OFF

6. After the test is completed, to restore the original host USB interface, you can choose any of the following methods:
 - Press "Return to Main" in the software to exit the "Hub Test" menu, then press "Exit" to exit the program. After the program exits, the USB communication interface will be automatically reset, and the host USB interface used for testing can be restored for use.
 - Through remote control, open the computer's device manager. At this time, the original serial bus controller will be replaced by "USB Compliance Controllers". Right-press "xHCI Compliance Test Host Controller" under its directory, select "Update Driver", and then refer to the operations in "Driver Installation" to change the compatible hardware back to "USB xHCI Host Controller".



RIGOL
RIGOL