



## Acuros<sup>®</sup> CQD<sup>®</sup> 640L USB3 SWIR Camera

The Acuros<sup>®</sup> CQD<sup>®</sup> L-Series SWIR cameras feature large sensor area, low angular dependence and a short working distance for highly divergent emitters or collimated beams. Acuros cameras deliver high resolution, high dynamic range and very high detectivity imaging from 400 nm to 1700 nm.

The L-Series cameras are designed for use in laser beam diagnostics, laser beam imaging and laser alignment applications.

### Specifications:

#### Electro-Optical Specifications:

Sensor	Acuros <sup>®</sup> CQD <sup>®</sup> sensor
Temperature stabilization	Single-stage thermo-electric cooler
Sensor array format	640 x 512
Resolution	0.33 megapixels
Spectral band	400 nm - 1700 nm
Array size	9.6 mm x 7.7 mm, 12.3 mm diagonal
Pixel pitch	15 μm x 15μm
Max frame rate at full resolution	270 fps (8, 10, 12, 14 bit)
Pixel operability	99.9% typical, 99.75% min
Bit depth	8, 10, 12, 14 bit selectable
Integration type	Snapshot global shutter
Trigger	External TTL
Integration time	10 μsec to 4 sec
Dynamic range	70 dB typical
Windowing & windowing frame rate	Array centered. Scales inversely to window size
Laser beam fringeless operation	Yes
Binning arrays	2 x 2, 4 x 4
Non-uniformity correction	2-point non-uniformity correction
Temporal dark noise	65e <sup>-</sup> typical (high gain)
Quantum efficiency	See typical QE curve.

### Features:

- Large sensor size
- Short working distance for highly divergent beams
- Low angular dependence
- Dynamic Range up to 70 dB
- Linear photoresponse
- VGA Resolution
- TEC Cooling
- Low noise
- GigE Vision
- Visible-SWIR

### Applications:

- Laser beam diagnostics
- Laser beam imaging
- Laser alignment



# SWIR<sup>®</sup>

VISION SYSTEMS

## Transforming Infrared Imaging

### Specifications:

#### Environmental & power specifications, typical performance

Operating case temperature	-20 °C to +55 °C
Power consumption	6.5 - 12 W depending on TEC settings
Power supply voltage	6-16 VDC
Regulatory compliance	CE mark

#### Mechanical specifications

Dimensions excluding lens	6.1 x 6.1 x 8.2 cm
Weight excluding lens	508 grams
Lens mounts	Standard mount. Inquire for other options.
Power connector	Hirose 12-pin, HR10A-10R-12PB (71)
Trigger connector	BNC

#### Software and user interface

Software development kit	Windows GUI & Pleora eBUS SDK (Linux, Windows, MacOS)
GenICam compliance	Yes
Interface	USB3 Vision

#### Export compliance

US export designation	EAR-99. No license required for lawful export
-----------------------	---

#### Ordering

Part numbers	640L: Acuros-0640-USB3-003
--------------	----------------------------



USB3 Vision Interface

### Acuros CQD SWIR camera image of Laser

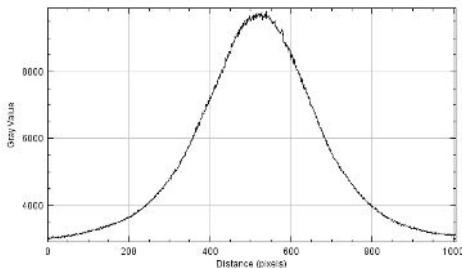
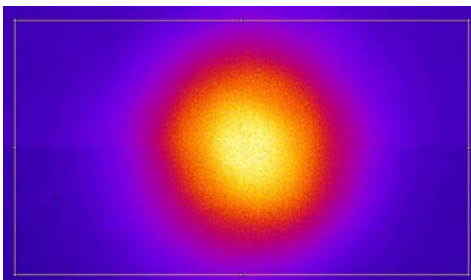

1550 NM Laser image and corresponding line file (false color added post image)

Angular Dependence Data

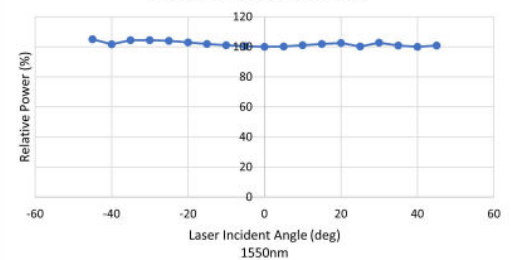

Typical QE Performance

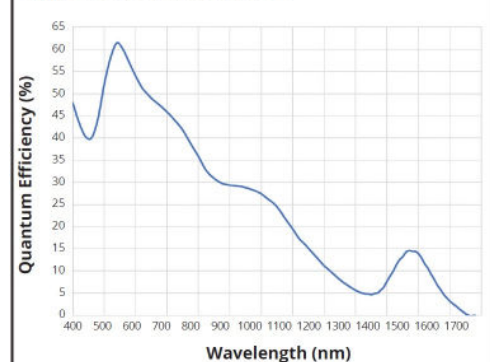

**Acuros-0640-USB3-003**



# SWIR<sup>®</sup>

VISION SYSTEMS

Transforming Infrared Imaging

## Mechanical Drawings

\*\*Additional ND filter mounting options are available. For more information, contact us at [sales@swirvisionsystems.com](mailto:sales@swirvisionsystems.com)

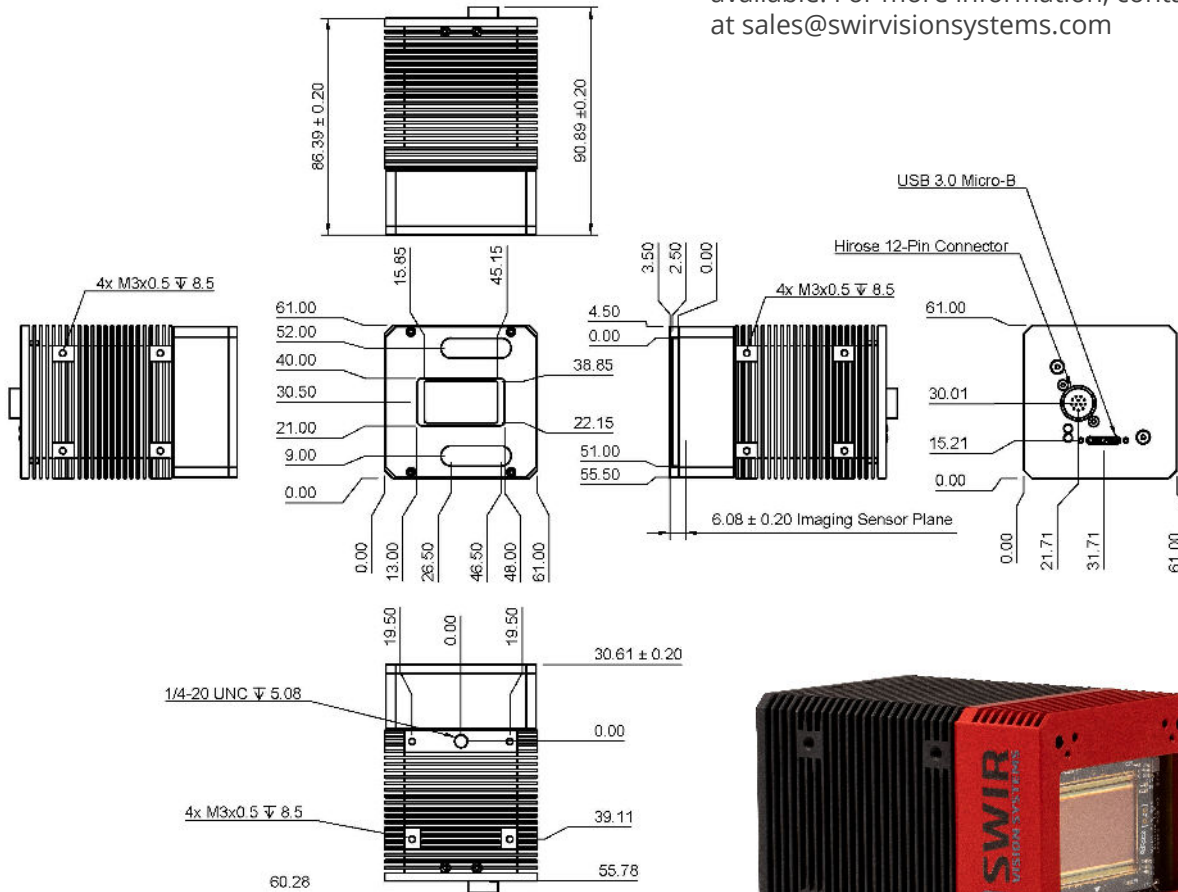

Distribution in the UK & Ireland



**Lambda Photometrics Limited**  
 Lambda House Batford Mill  
 Harpenden Herts AL5 5BZ  
 United Kingdom  
 E: [info@lambdaphoto.co.uk](mailto:info@lambdaphoto.co.uk)  
 W: [www.lambdaphoto.co.uk](http://www.lambdaphoto.co.uk)  
 T: +44 (0)1582 764334  
 F: +44 (0)1582 712084

**Characterisation,  
 Measurement &  
 Analysis**



GEN*i*CAM

**GiGE**  
 VISION



Acuros-0640-USB3-003