

SYSTEM	
Measurement Technique	Non-contact, three-dimensional, coherence scanning interferometry with field stitching
Applications	Optical surface form and texture; optical surface deviation from design; relational metrology of mechanical and datum features
Scanner	Closed-loop piezo-based, with highly linear capacitive sensors
Objectives	2.5X for relational / 20X for surface (typ); 10X and 50X optional for surface; See the Nexview & NewView Series Objective Chart for more details
Objective Mounting	Motorized 4-position turret
Field Zoom Lenses	Motorized 3-position encoded zoom • 0.5X, 0.75X, 1.5X included
Field of View	Objective and zoom selectable
Illuminator	Single white-light LED with long life, uniform imaging and high efficiency
Measurement Array	Selectable: 1408 x 1408, 1024 x 1024
Z-Drive (Focus) Stage	100 mm range with 0.1 μm resolution
Part Stage	5-axis containing X, Y, Pitch, B, C,
Sample Holder	Vacuum Chuck for flat base pin tooling and Universal adhesive lens holder included
Vibration Isolation	3D pneumatic isolation legs included Active solution optional
PHYSICAL	
Dimensions (HWD)	System & encl: ~160 x 116 x 106 cm Electronics Rack: ~138 x 61 x 96 cm Typ. Footprint (WD): 185 x 172 cm
Weight	System & Encl: 820 kg Electronics Rack: 76 kg
UTILITY REQUIREMENTS	
Input Voltage	100 to 240 VAC, 50/60 Hz
Compressed Air for Table	4.1 to 5.5 bar (60 to 80 psi); dry and filtered; 6 mm OD hose input
ENVIRONMENTAL REQUIREMENTS	
Temperature	20 to 23°C with +/- 0.1°C stability <small>*required for performance to specification</small>
Temperature Change	<0.2°C per hr and <1°C per 24 hr <small>*maximum allowed thermal change</small>
Humidity	5 to 95% relative, noncondensing
Floor / Acoustic Vibration limits	VC-C or better / NC-30 or better
TEST PART CHARACTERISTICS	
Sample Types	High-precision glass or plastic injection molded lenses and optical devices, diamond-turned molds. with a CA < 8 mm for form and CA < 6.4 mm for relational
Material	Uncoated metal, glass, and plastic w/ reflectivity between 0.05% - 100%
Geometries	Continuous and rotationally symmetric spheres, gullwings, pancakes, and other asphere shapes plus freeforms



PERFORMANCE	
Specification Description	Target performance 1 σ reproducibility
Aspheric Surface Form Error	0.010 μm (RMS), 0.030 μm (PV)
Aspheric Surface Roughness	0.005 μm (Sa)
Lens Height	0.17 μm
Tilt Control Interlock Flatness	0.02 μm
Side1-Side2 Concentricity	0.1 μm
A1-A2 Concentricity	0.25 μm
Lens Concentricity to Interlock	0.16 μm
Interlock Diameter	0.05 μm
Thickness at Center	0.34 μm
Tilt Control Interlock Parallelism	10 arc sec
Tilt Control Interlock Thickness	0.24 μm
MEASUREMENT MODES	
3D Form & Texture	Full area topography, waviness, and texture (tooling marks, artifacts, etc.) measurement defined by: <ul style="list-style-type: none"> • OpticStudio & CODE V prescription • Unknown surface tracking
Form Deviation	Full area deviation map when lens is measured using a surface equation
Production Form Deviation Mode	Ring-spoke form deviation method for increased throughput with reduced data density
Relational	Flatness, thickness, and centration of lens surface to mechanical datums. Capability is surface dependent
FOOTNOTE	
Performance specifications under laboratory conditions using standard specimens, according to ISO 25178-601, 25178-604 and 5436-1.	

Distribution in the UK & Ireland

Lambda Photometrics Limited
 Lambda House Batford Mill
 Harpenden Herts AL5 5BZ
 United Kingdom
Characterisation, Measurement & Analysis
 E: info@lambdaphoto.co.uk
 W: www.lambdaphoto.co.uk
 T: +44 (0)1582 764334
 F: +44 (0)1582 712084

DIAMOND TURNING MACHINE (DTM) INTEGRATION

Jig Support	Compass 2 includes a vacuum chuck fixture supporting DTM chuck/jigs with <ul style="list-style-type: none"> • Diameter 16 mm – 115 mm • Weight up to 0.8 kg
DTM Tool Setup Support	Compass 2 supports DTM Tool setup with <ul style="list-style-type: none"> • Tool offset and tool radius measurement for spheres and aspheres • Report predicted surface deviation after offset and radius correction
DTM Toolpath Generation	Compass 2 data may be used to optimize a DTM toolpath <ul style="list-style-type: none"> • Export profile deviation data for use with multiple DTM platforms <ul style="list-style-type: none"> ◦ Precitech DIFFSYS software ◦ Toshiba Diamond Turning Machine Software • Export 3D deviation from design in multiple formats <ul style="list-style-type: none"> ◦ Zernike Polynomial model ◦ High resolution XYZ model
Surface Finish Metrology	Compass 2 has the necessary XYZ precision to report roughness level data that includes <ul style="list-style-type: none"> • Automatic generation of high frequency texture and tooling mark surface maps • Automatically use surface maps to rapidly navigate to a specific location for more detailed inspection

VACUUM CHUCK DETAILS

The Compass 2 Vacuum Chuck accommodates typical DTM jig diameters 16-115 mm

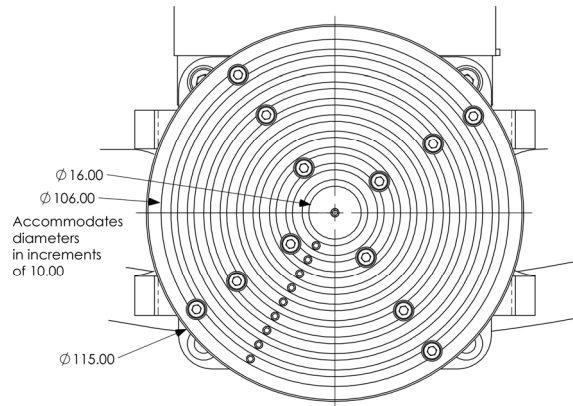

Dimensions in mm

TYPICAL TOOL LAYOUT

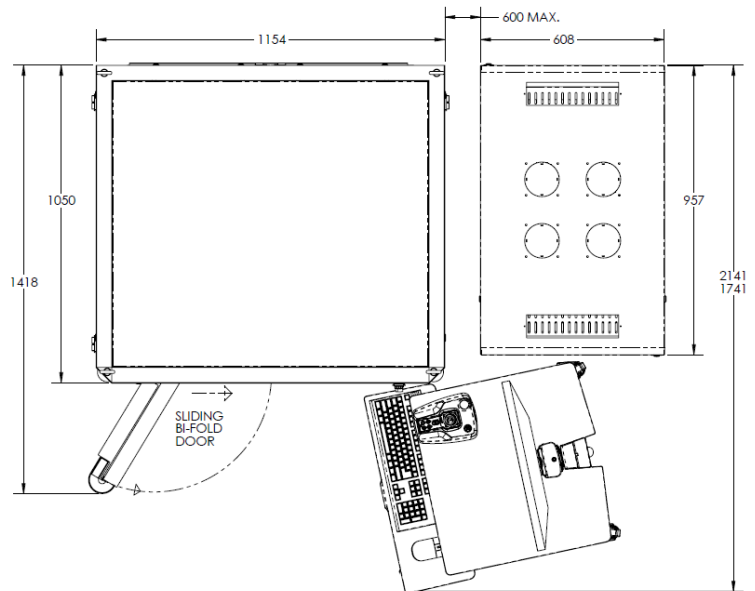
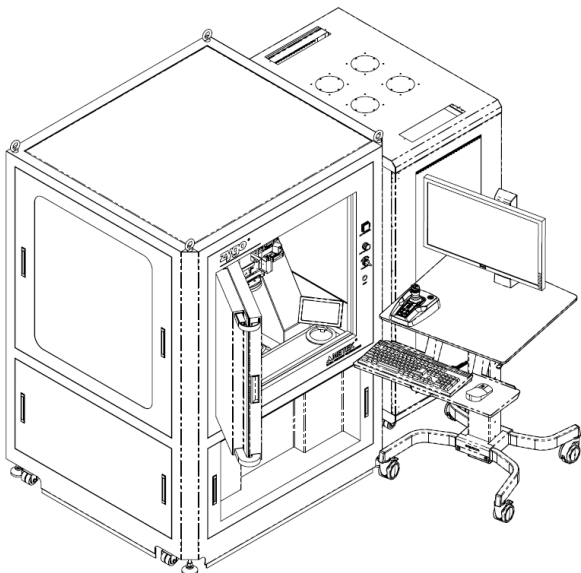

Dimensions in mm

A customer reference drawing is available upon request