

# Optical Complex Spectrum Analyzer (OCSA)

First version 01/12/2003 Last Update 07/06/2013

Chromatic Dispersion measurement using  
Optical Complex Spectrum Analyzer



Distribution in the UK & Ireland



**Characterisation,  
Measurement &  
Analysis**

**Lambda Photometrics Limited**  
Lambda House Batford Mill  
Harpenden Herts AL5 5BZ  
United Kingdom

**E: [info@lambdaphoto.co.uk](mailto:info@lambdaphoto.co.uk)**  
**W: [www.lambdaphoto.co.uk](http://www.lambdaphoto.co.uk)**  
**T: +44 (0)1582 764334**  
**F: +44 (0)1582 712084**

# Chromatic Dispersion measurement using Optical Complex Spectrum Analyzer

Based on complex spectral analysis of the optical field, the Optical Complex Spectrum Analyzer AP2441B/AP2443B is able to measure the chromatic dispersion and the group delay of a transmission line. This paper is dedicated to explain clearly the measurement method of two examples of a 13.2 km standard Single Mode Fiber (SMF) length using a 10 Gb/s modulated signal produced by a Mach Zehnder modulator and a 12.4 km SMF using an optical frequency comb generator. Optional software (OCSA04-Group delay and chromatic dispersion analysis) can be integrated in the equipment in order to display the group delay and the chromatic dispersion as function of the wavelength/frequency. For accuracy issues, the paper presents a solution by using averaging functions.

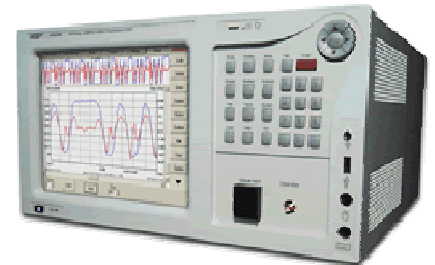

## Chromatic Dispersion in Optical fibers

One of the most important features of the optical transmission is the signal broadening during propagation of different spectral components in an optical fiber. This phenomenon known as chromatic dispersion refers to propagation time differences in the fiber. It manifests through the frequency dependence of the refractive index  $\tilde{n}(\omega)$ . On a fundamental level, the origin of chromatic dispersion is related to the frequency dependent absorption characteristics of the optical fiber. The resonance frequencies (in the absorption characteristics) correspond to enhanced absorption of electromagnetic radiation through oscillations of bound electrons.

Fiber dispersion plays a critical role in propagation of short optical pulses because different spectral components associated with the pulse travel with different group velocities. Accordingly, chromatic dispersion is known as group-velocity dispersion (GVD). The consequence of chromatic dispersion is the broadening of the single pulse and interference between adjacent pulses known as inter-symbol-interference (ISI). Even when nonlinear effects are not important, dispersion-induced pulse broadening can be detrimental and could severely restrict the performance of a telecommunication system.

Mathematically, the effects of fiber dispersion are accounted for by expanding the mode propagation constant  $\beta$  in a Taylor series about the carrier frequency  $\omega_0$  at which the pulse spectrum is centered :

$$\beta(\omega) = \beta_0 + \beta_1(\omega - \omega_0) + \frac{1}{2!}\beta_2(\omega - \omega_0)^2 + \dots \quad (1)$$

where

$$\beta_n = \left( \frac{d^n \beta}{d\omega^n} \right) \Bigg|_{\omega=\omega_0} \quad \text{with } n = 0, 1, 2, \dots \quad (2)$$

The parameters  $\beta_1$  and  $\beta_2$  are related to the fiber refractive index  $n'$  and its derivatives through the relations:

$$\beta_1 = \frac{1}{v_g} = \frac{\tau_g}{L} = \frac{1}{c} \left( n' + \omega \frac{dn'}{d\omega} \right) \quad (3)$$

$$\beta_2 = \frac{1}{c} \left( 2 \frac{dn'}{d\omega} + \omega \frac{d^2n'}{d\omega^2} \right) \quad (4)$$

where  $\zeta_g$  is the group index and  $v_g$  is the group velocity. Physically, the envelope of an optical pulse moves at the group velocity while the parameter  $\beta_2$  represents the dispersion of the group velocity. This dispersion of the group velocity is responsible for pulse broadening and hence  $\beta_2$  is referred as the group velocity dispersion (GVD) parameter.

The quantity dispersion coefficient  $D$  (also called as dispersion parameter) usually expressed in ps/(nm·km) is frequently used in the fiber-optics literature in place of  $\beta_2$ . The dispersion coefficient is a measure of the broadening of a pulse due to its finite spectral width over one kilometer (km) of fiber propagation. The two quantities are related to each other as :

$$D(\lambda) = \frac{d\beta_1}{d\lambda} = \frac{d\tau_g}{d\lambda} = -\frac{2\pi c}{\lambda^2} \beta_2 \approx -\frac{\lambda}{c} \frac{d^2n'}{d\lambda^2} \quad (5)$$

In the following paragraph, we will detail the calculation steps of the Chromatic Dispersion and Group delay as function of the frequency. All these steps are made internally by the Optical Complex Spectrum Analyzer AP2441B/AP2443B, an optional software (OCSA04-Group delay and chromatic dispersion analysis) is integrated in the equipment in order to just display the group delay and the chromatic dispersion as function of the wavelength/frequency.

## Chromatic Dispersion calculation steps

### ▪ Phase difference measurement

#### ✓ Experimental setup

The first step is to calculate the Chromatic Dispersion (CD) and the Group Delay of a transmission line is to compare the complex spectrum of a periodical optical signal (test signal) measured before (back-to-back) and after transmission. The figure 1 shows the experimental setup of two CD calculation examples. In first example we measure the CD of of a 13.2 km standard Single Mode Fiber (SMF) length using a 10 Gb/s modulated signal produced by a Mach Zehnder modulator while the second example for a 12.4 km SMF using an optical frequency comb generator with 2.5 GHz repetition frequency.

**Example 1:**

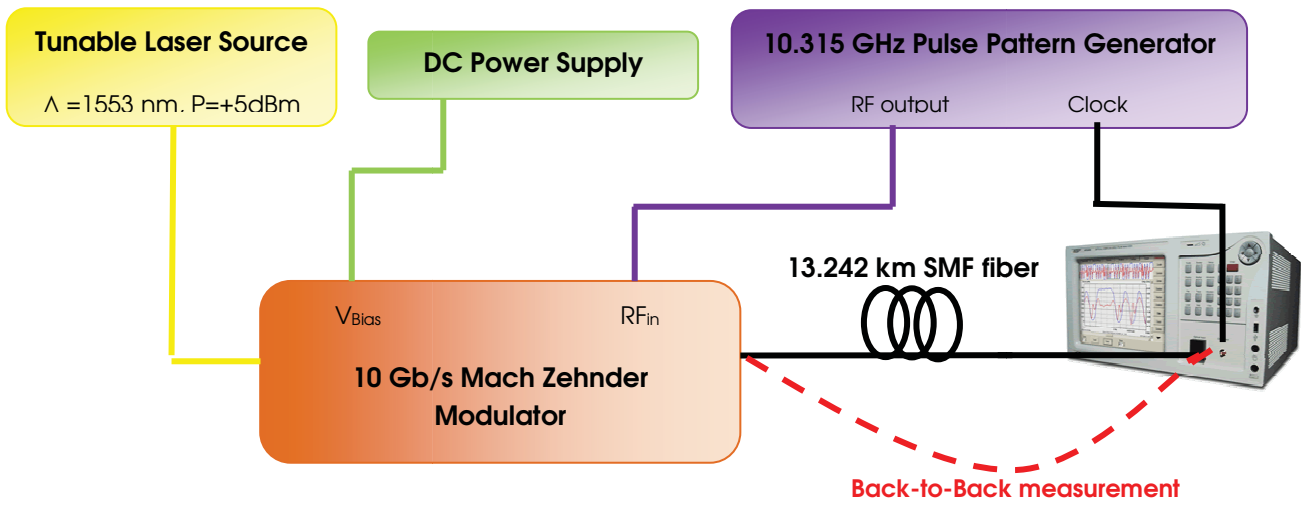

**Example 2:**

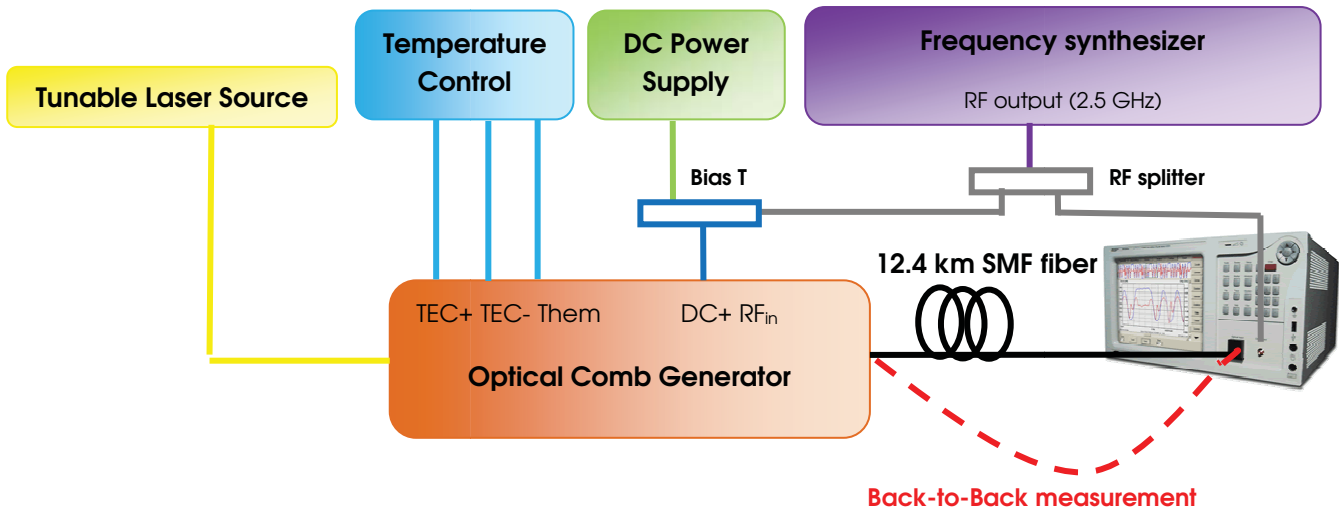

Figure 1: Experimental setup of phase difference measurement before and after transmission using the Optical Complex Spectrum Analyzer, 10 Gb/s Mach Zehnder Modulator (example 1) and the Optical Comb Generator (example 2)

✓ **Experimental results**

Let us consider an optical signal whose spectrum is defined by the electromagnetic field amplitude  $A$  and phase  $\Phi$  of its spectral components located at wavelength  $\lambda$ .

For each of these spectral components, the electromagnetic field propagating through a transparent medium can be written as :

$$E(z,t) = \sum_n A_n(z,t) \exp(i(\omega_n t + \Phi_n - \beta(\omega_n)z)) \quad (6)$$

Where  $A_n$ ,  $\omega_n$  and  $\Phi_n$  are respectively the amplitude, angular frequency and the optical phase of the  $n^{\text{th}}$  mode in the optical spectrum.  $\beta$  is the propagation constant defined in (1). Thus the  $n^{\text{th}}$  mode optical phase variation induced by the transmission through a length  $L$  of such medium is quadratic:

$$\Delta\Phi_n(\omega_n) = \Phi_{n,after} - \Phi_{n,before} = -\beta(\omega_n)L \quad (7)$$

Figures 2 and 3 depict the parabolic distribution of the optical phase difference (equation (7)) as function of the wavelength/frequency measured by the Optical Complex Spectrum Analyzer respectively related to the examples 1 and 2.

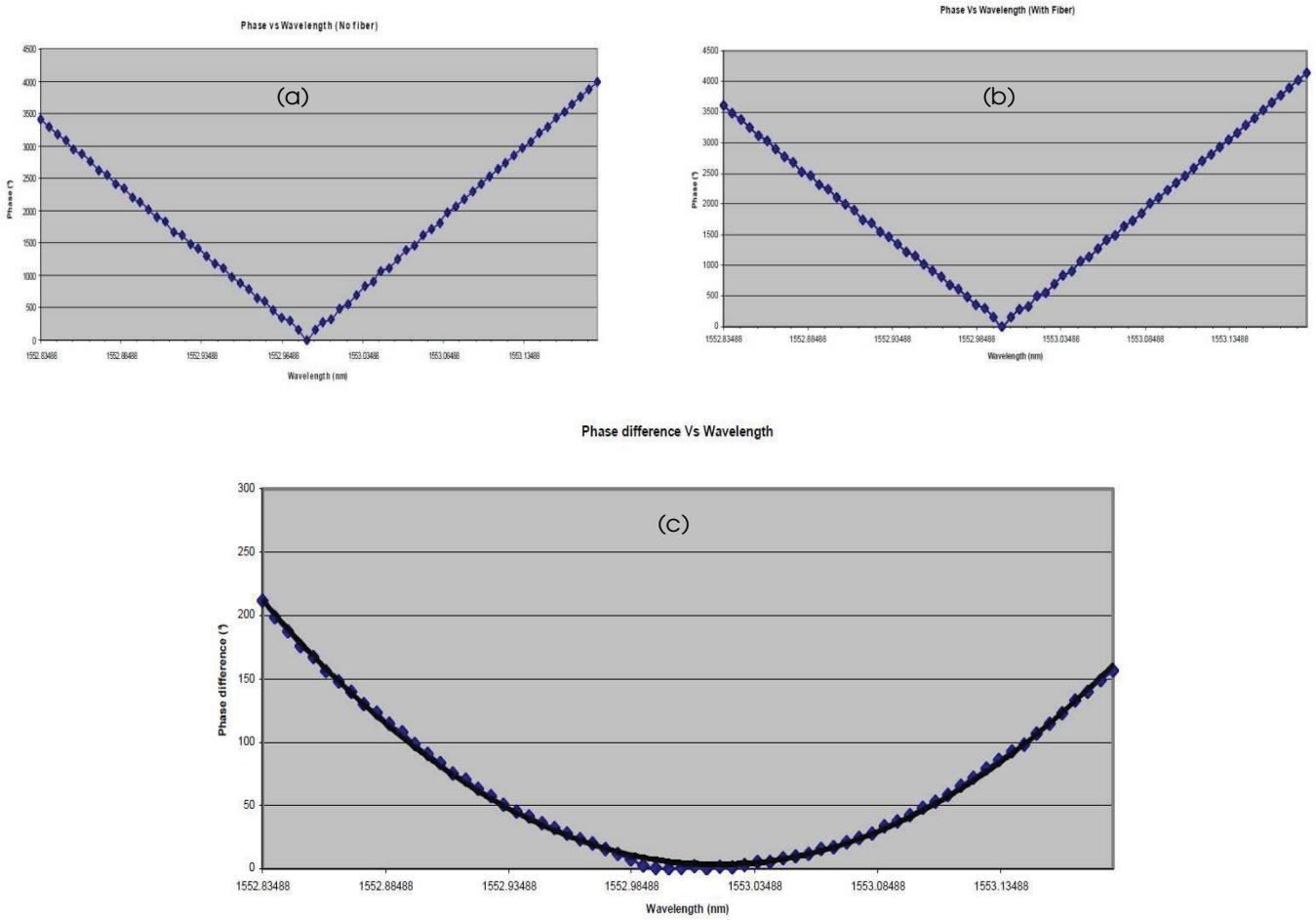

Figure 2: The optical phase as function of wavelength measured using a 10 Gb/s Mach Zehnder Modulator related to the Back-to-Back case (a) and after transmission (b), The resulting phase difference measurement (c)

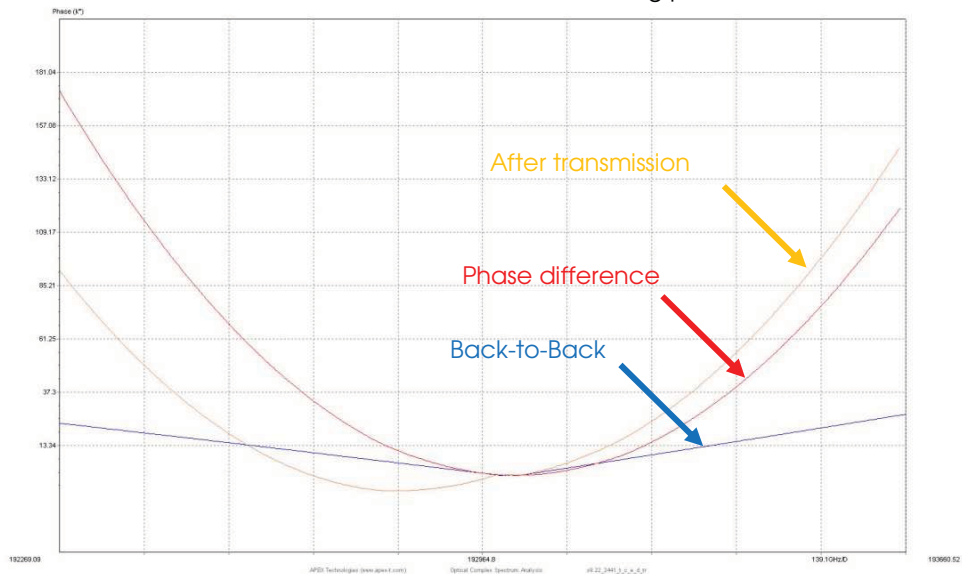

Figure 3: The optical phase as function of wavelength measured using an Optical Frequency Comb generator related to the Back-to-Back case (blue trace) and after transmission (yellow trace), The resulting phase difference measurement (red trace)

## Group Delay and Chromatic Dispersion Calculation

Using (1) and (7), the derivative of the  $n^{\text{th}}$  mode optical phase variation with respect to the wavelength  $\omega_n$  is given by:

$$\frac{d\Delta\Phi_n(\omega_n)}{d\omega_n} = -\frac{d\beta(\omega_n)}{d\omega_n} = -\beta_1 - \beta_2(\omega_n - \omega_0) - \dots \quad (8)$$

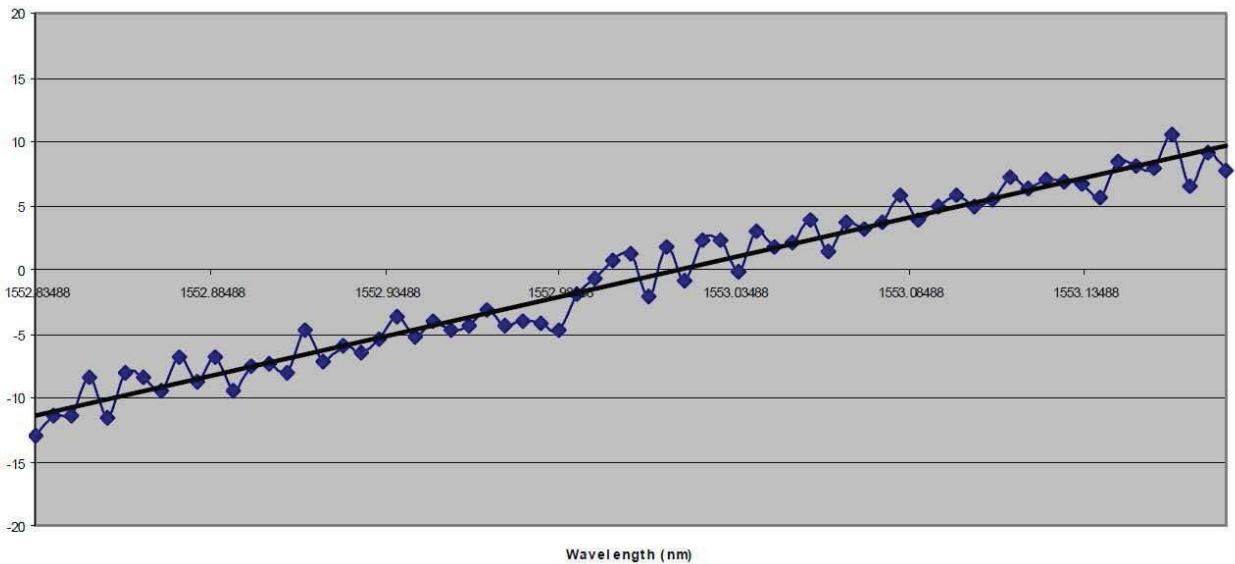

Figure 4: The calculated Group Delay as function of wavelength (blue trace) related to 13.242 km transmission line using a 10 Gb/s Mach-Zehnder modulator. The black trace corresponds to corresponding fit function.

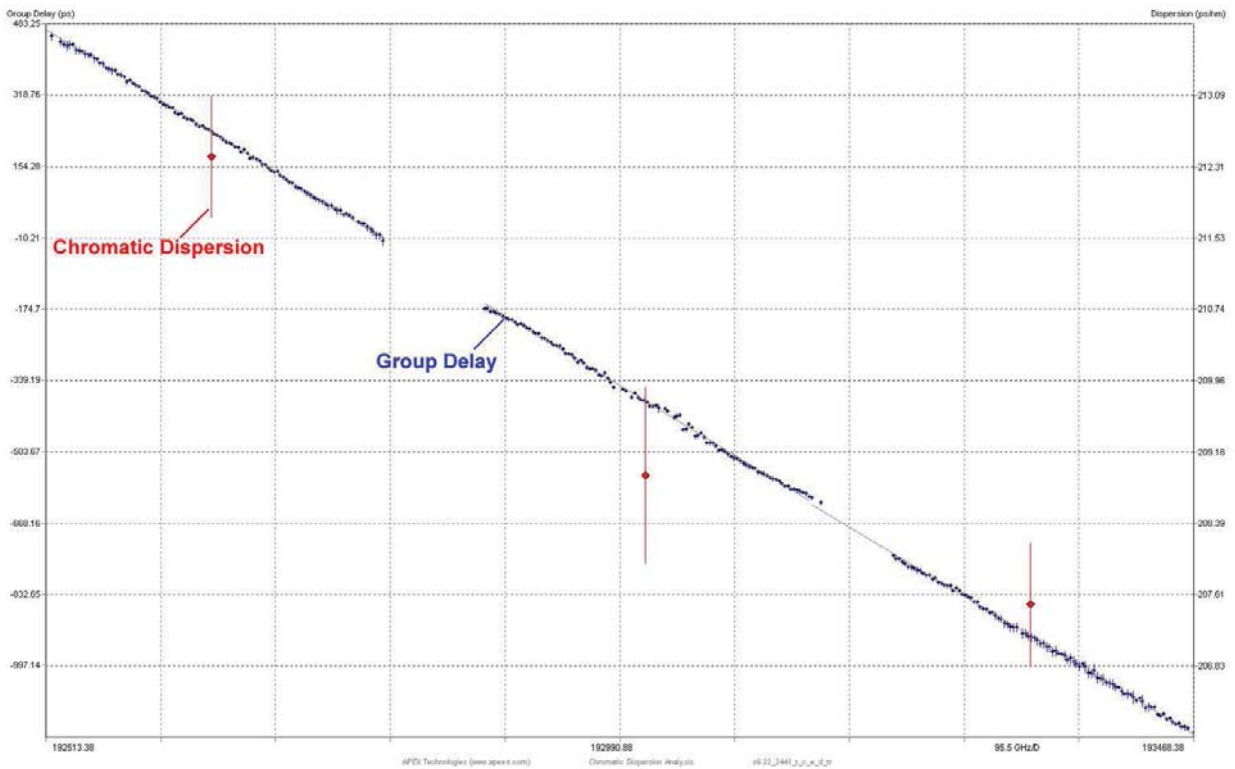

Figure 5: The Group Delay as function of wavelength (blue trace) related to 12.4 km transmission line using a Comb generator. The Group Delay is calculated for three wavelength sections of the Phase difference curve (figure 3). The red points correspond to the calculated chromatic dispersion values relative to the three sections.

The parabolic distribution of the optical phase difference (figure 2(c) and (3)) is divided into a certain number of wavelength sections. The Group Delay and the Chromatic Dispersion calculation are carried out section by section. In each section, we consider that the derivative of the n<sup>th</sup> mode optical phase variation with respect to the wavelength  $\omega_n$  can be estimated by:

$$\frac{d\Delta\Phi_n(\omega_n)}{d\omega_n} = \frac{\Delta(\Delta\Phi_n(\omega_n))}{\Delta\omega_n} = \frac{\Delta\Phi_{n,n+1}}{\Delta\omega_n} = \frac{\Delta\Phi_{n+1}(\omega_{n+1}) - \Delta\Phi_n(\omega_n)}{\omega_{n+1} - \omega_n} \quad (9)$$

Where  $\Delta\Phi_{n,n+1}$  is the relative variation of the optical phase difference between two consecutive spectral modes. By limiting the calculation to the first term of the propagation constant  $\beta_1$ , the group delay is given by:

$$\tau_g(\omega_n) = -L \frac{\Delta\Phi_{n,n+1}}{\Delta\omega_n} \quad (10)$$

Figure 4 and 5 show the linear distribution of the calculated Group Delay (equation (10)) as function of wavelength/frequency using the optical phase difference measurements.

According to the equation (5), the Chromatic Dispersion, expressed in ps/nm, corresponds to the slope of the Group Delay variation. It is estimated by linear fit of the group delay points with respect to wavelength/frequency. As shown in figure 5, the chromatic dispersion is represented by a red point for each calculation section.

## ▪ Averaging function to overcome accuracy problems

An accuracy problem can be manifested in the the group delay measurement. This is related to the level difference between modes of the signal under test and phase measurement accuracy problem of the lowest modes.

To overcome this kind of problem, the optional software (OCSA04-Group delay and chromatic dispersion analysis) uses a a weighted linear fit. Indeed, the most accurate points have the most important weight in the fit, and the points whose accuracy is far poorer than the average accuracy will be removed from the fit.

After removal of unaccurate or abnormal points from preliminary fit, a second fit is applied and displayed as a straight line passing through the group delay points. The red line in figure 5 is the calculated uncertainty of the chromatic dispersion values in each section.

In addition, using the averaging function allows us to verify the accuracy of the Group Delay measurement through its deviation (°) from the linear fit. Figure 6 shows the high efficiency of the averaging function in improving the Group Delay and Chromatic Dispersion measurement accuracy. Indeed, without averaging, the Group Delay deviation is around 10° (figure 5(a)) while it is around 3° with 10 averaging (figure 5(c)).

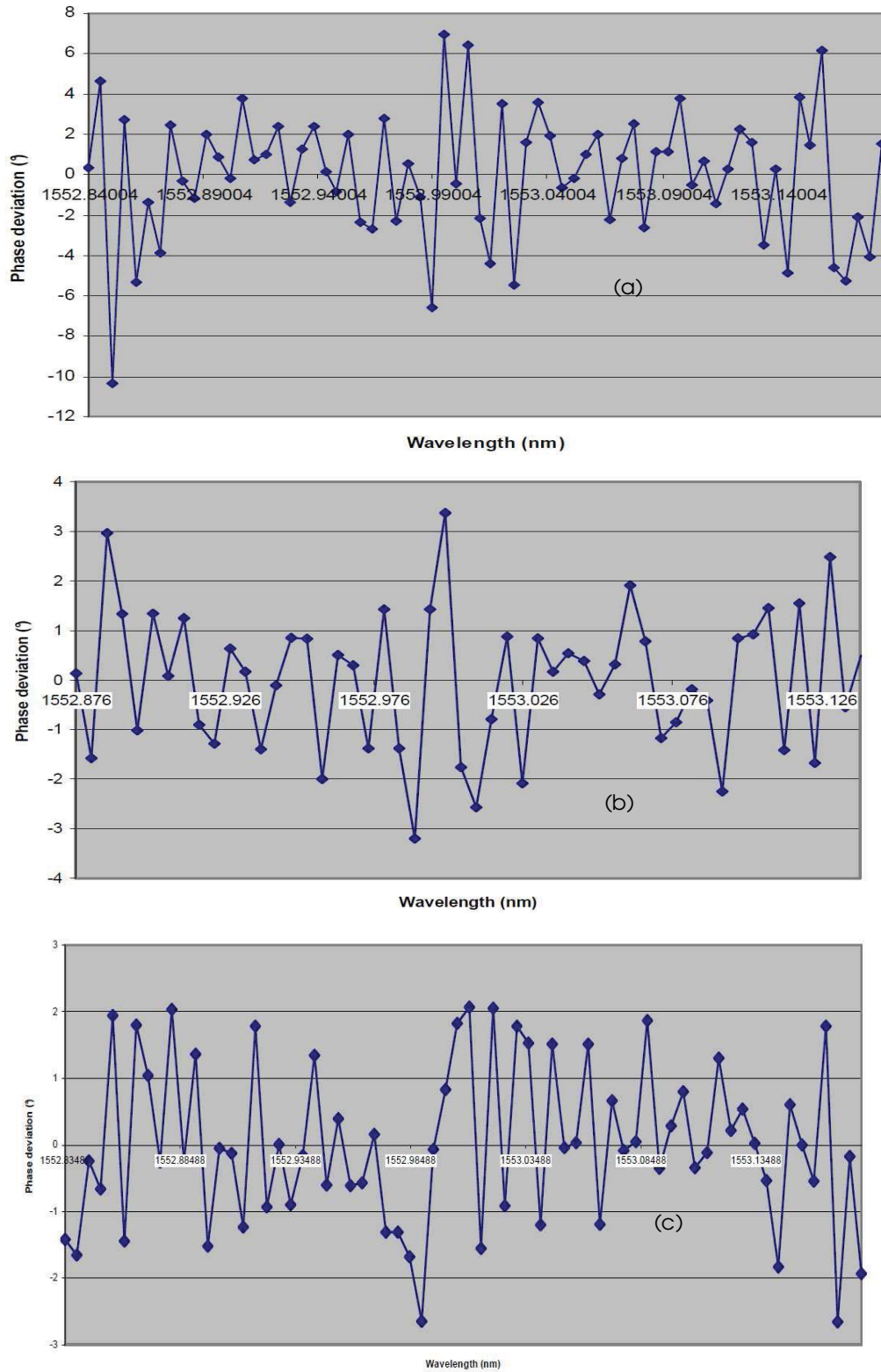

Figure 6: The Group Delay deviation for one wavelength section related to 13.242 km transmission line using a 10 Gb/s Mach-Zehnder modulator, The Group Delay deviation is measured without averaging function (a), with 5 averaging (b) and 10 averaging (c)



## Conclusion

The Apex Technologies Optical complex Spectrum Analyzer (OCSA) is a high efficient tool for measuring the Group Delay and the Chromatic Dispersion of transmission lines. By integrating the Optional software (OCSA04), you will not only be able to quickly analysis and display the Group Delay and Chromatic Dispersion of your transmission line but also to solve the accuracy issues through the use of the weighted linear fit function as well as the averaging function for the optical phase difference measurement before and after transmission.

## Contact

**Apex Technologies**

9bis, rue Angiboust

91460 MARCOUSSIS

FRANCE

Tel : +33 1 69 63 26 30

Fax : +33 1 69 63 26 37

Email : [info@apex-t.com](mailto:info@apex-t.com)Web site: [www.apex-t.com](http://www.apex-t.com)